



KRAMER ELECTRONICS LTD.

USER MANUAL

MODEL:

840HxI

Pattern Generator

P/N: 2900-300032 Rev 7



840Hxl Pattern Generator Quick Start Guide

This guide helps you install and use your **840Hxl** for the first time. For more detailed information, go to <http://www.kramerav.com/manual/840Hxl> to download the latest manual or scan the QR code on the left.

Step 1: Check what's in the box

- 840Hxl** Pattern Generator
- 1 Quick Start Guide
- 1 Power Adapter 5V DC
- 4 Rubber feet

Step 2: Install the 840Hxl

Attach the rubber feet to the bottom of the device and place it on a stable surface.

Step 3: Connect the input and output

Always switch off the power to the display before connecting it to your **840Hxl**.
For best results, always use Kramer high-performance cables to connect your AV equipment to the **840Hxl**.

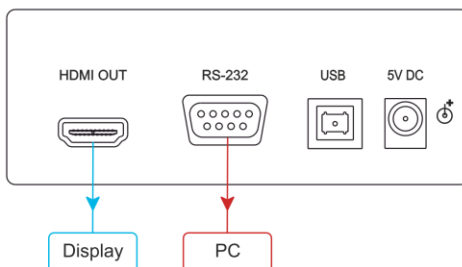

Step 4: Connect the power

Connect the 5V DC power adapter to the **840Hxl** and plug the adapter into the mains electricity.



Step 5: Connect the power

Set the parameters using the front panel buttons and/or the Controller Software (available from our Web site).

RESOLUTION
 PATTERN
 COLOR SPACE
 HDCP
 AUDIO SAMPLING FREQUENCY

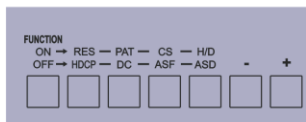

Contents

1	Introduction	1
2	Getting Started	2
2.1	Achieving the Best Performance	2
2.2	Safety Instructions	2
2.3	Recycling Kramer Products	3
3	Overview	4
4	Defining the 840Hxl Pattern Generator	5
5	Connecting the 840Hxl	7
5.1	Connecting to a PC	8
6	Operating the 840Hxl Pattern Generator	9
6.1	Operating the 840Hxl Using the Front Panel Buttons	11
6.2	Operating the 840Hxl Using the Control Application	12
7	Technical Specifications	23
8	Serial Protocol	24
8.1	Command Format	24
8.2	Device Response	24
8.3	Commands	25

Figures

Figure 1:	840Hxl Pattern Generator Front Panel	5
Figure 2:	840Hxl Pattern Generator Rear Panel	6
Figure 3:	Connecting the 840Hxl Pattern Generator	7
Figure 4:	Found New Hardware Wizard Window	13
Figure 5:	File Location Selection Window	14
Figure 6:	Insert Disk Window	15
Figure 7:	Connection Method Window	15
Figure 8:	Connection Error Message	16
Figure 9:	Controller Software Main Window	17
Figure 10:	Menu Bar	19
Figure 11:	About	19
Figure 12:	User Defined Resolution Window	20
Figure 13:	User Defined Resolution Advanced Window	21
Figure 14:	User Defined Resolution Advanced Window—Detailed Timing Descriptor Tab	22

1 Introduction

Welcome to Kramer Electronics! Since 1981, Kramer Electronics has been providing a world of unique, creative, and affordable solutions to the vast range of problems that confront the video, audio, presentation, and broadcasting professional on a daily basis. In recent years, we have redesigned and upgraded most of our line, making the best even better!

Our 1,000-plus different models now appear in 13 groups that are clearly defined by function: GROUP 1: Distribution Amplifiers; GROUP 2: Switchers and Routers; GROUP 3: Control Systems; GROUP 4: Format/Standards Converters; GROUP 5: Range Extenders and Repeaters; GROUP 6: Specialty AV Products; GROUP 7: Scan Converters and Scalers; GROUP 8: Cables and Connectors; GROUP 9: Room Connectivity; GROUP 10: Accessories and Rack Adapters and GROUP 11: Sierra Products; Group 12: Digital Signage; GROUP 13: Audio; and GROUP 14: Collaboration.

Congratulations on purchasing your Kramer MultiTOOLS® **840Hxl** *Pattern Generator*, which is ideal for the following typical applications:

- As a diagnostic tool in AV setups
- Testing and adjusting flat panel LCD displays, projectors, plasma screens and HDMI cables

2 Getting Started

We recommend that you:

- Unpack the equipment carefully and save the original box and packaging materials for possible future shipment
- Review the contents of this user manual



Go to www.kramerav.com/downloads/840HxI to check for up-to-date user manuals, application programs, and to check if firmware upgrades are available (where appropriate).

2.1 Achieving the Best Performance

To achieve the best performance:

- Use only good quality connection cables (we recommend Kramer high-performance, high-resolution cables) to avoid interference, deterioration in signal quality due to poor matching, and elevated noise levels (often associated with low quality cables)
- Do not secure the cables in tight bundles or roll the slack into tight coils
- Avoid interference from neighboring electrical appliances that may adversely influence signal quality
- Position your Kramer **840HxI** away from moisture, excessive sunlight and dust



This equipment is to be used only inside a building. It may only be connected to other equipment that is installed inside a building.

2.2 Safety Instructions



Caution: There are no operator serviceable parts inside the unit

Warning: Use only the Kramer Electronics power supply that is provided with the unit

Warning: Disconnect the power and unplug the unit from the wall before installing

2.3 Recycling Kramer Products

The Waste Electrical and Electronic Equipment (WEEE) Directive 2002/96/EC aims to reduce the amount of WEEE sent for disposal to landfill or incineration by requiring it to be collected and recycled. To comply with the WEEE Directive, Kramer Electronics has made arrangements with the European Advanced Recycling Network (EARN) and will cover any costs of treatment, recycling and recovery of waste Kramer Electronics branded equipment on arrival at the EARN facility. For details of Kramer's recycling arrangements in your particular country go to our recycling pages at <http://www.kramerelectronics.com/support/recycling/>.

3 Overview

The **840Hxl** is a high performance HDMI video test pattern generator. It can generate 32 preset patterns (including several unique patterns incorporating motion) at 42 popular, predefined computer and HD video resolutions.

In particular, the **840Hxl** features:

- An HDMI output
- Five dual-function and two single-function control buttons
- A two-digit 7 segment display
- An onboard EPROM that saves the last settings
- Remote control via the 840Hxl software application

4 Defining the 840Hxl Pattern Generator

Figure 1 defines the front panel of the 840Hxl.

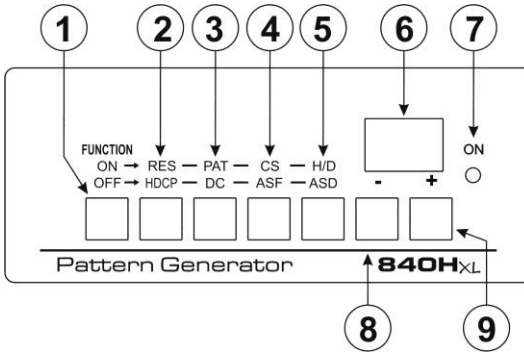

Figure 1: 840Hxl Pattern Generator Front Panel

#	Feature	Function
1		<i>ON/OFF</i> Press to toggle on and off. Button LED lights when on. When on, the top row of functions are enabled (RES, PAT, CS and H/D). When off, the bottom row of functions (HDCP, DC, ASF and ASD) are enabled (see Section 6.1)
2	<i>FUNCTION</i> Buttons	<i>RES/HDCP</i> Press to select either the Resolution or HDCP functions
3		<i>PAT/DC</i> Press to select either the Pattern or Color Depth functions
4		<i>CS/ASF</i> Press to select either the Color Space or Audio Sample Frequency functions
5		<i>H/D / ASD</i> Press to select either the HDCP/DVI or Audio Sample Depth functions
6	2-digit 7-segment Display	Indicates the current setting. The display flashes if there is a problem communicating with the display, for example, if the display does not support HDCP or does not support the selected resolution
7	<i>ON</i> LED	Lights green when the device receives power
8	- Button	Press to step down through the list of available values
9	+ Button	Press to step up through the list of available values

[Figure 2](#) defines the rear panel of the **840Hxl**.

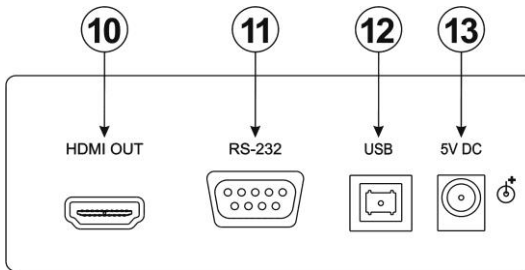

Figure 2: 840Hxl Pattern Generator Rear Panel

#	Feature	Function
10	<i>HDMI OUT</i> Connector	Connect to the HDMI acceptor
11	<i>RS-232</i> 9-pin D-sub Connector	Connect to the serial port on a PC for remote control (see Section 5.1.1)
12	<i>USB</i> Connector	Connect to the USB port on a PC for remote control
13	<i>5V DC</i> Connector	Connect to the power adapter

5 Connecting the 840Hxl



Always switch off the power to any device before connecting it to your **840Hxl**. After connecting your **840Hxl**, connect its power and then switch on the power to the device.

To connect the **840Hxl** as illustrated in the example in [Figure 3](#):

1. Connect the HDMI OUT connector to an HDMI acceptor (for example, a flat panel LCD display).
2. Optional—connect a PC to control the **840Hxl** via the RS-232 or USB ports.
3. Connect the power adapter to the 5V DC socket and to the mains electricity (not shown in [Figure 3](#)).

Note: The device must be connected to the 5V supply or it will not function correctly. If connected to a PC via the USB the device might appear to work but it will not function correctly.

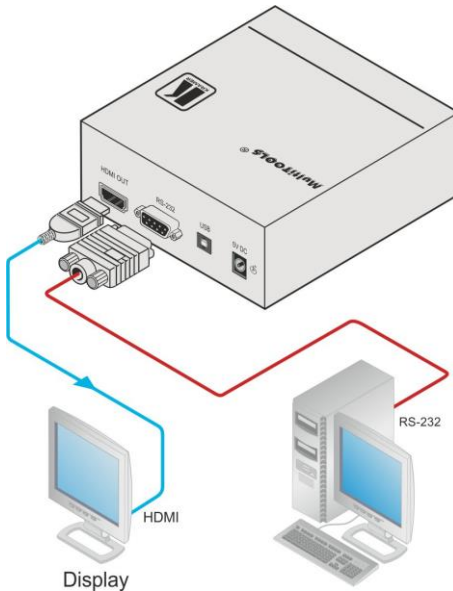

Figure 3: Connecting the 840Hxl Pattern Generator

5.1 Connecting to a PC

You can connect a PC either using the RS-232 port or the USB port.

5.1.1 Connecting a PC via the RS-232 Serial Port

You can connect to the **840Hxl** via an RS-232 connection using, for example, a PC. Note that a null-modem adapter/connection is not required.

To connect to the product via RS-232:

- Connect the RS-232 9-pin D-sub rear panel port on the product unit via a 9-wire straight cable (only pin 2 to pin 2, pin 3 to pin 3, and pin 5 to pin 5 need to be connected) to the RS-232 9-pin D-sub port on your PC

5.1.2 Connecting a PC via the USB Port

Note: The USB driver is only approved for use with Windows XP and not for use with Windows 7 or Windows 8. For these systems, use the serial connection.

To connect the **840Hxl** via a USB port:

1. Using a USB cable, connect the **840Hxl** to a USB port on the PC.
2. Install the USB driver as described in [Section 6.2.1](#).

6 Operating the 840Hxl Pattern Generator

The **840Hxl** can be operated either using the front panel buttons (see [Section 6.1](#)) or using the **840Hxl Control Application** (see [Section 6.2](#)).

The **840Hxl Control Application** is available as a free download from <http://www.kramerav.com/>.

You can choose from 24 resolutions (see [Figure 9](#)).

Common resolutions 1 through 17 are predefined. Resolution 24 is Output Native Resolution as shown in the table below.

Common Resolutions		
#	Resolution Name	Resolution
1	VGA	640 x 480 @60Hz
2		720 x 480 @60Hz
3	SVGA	800 x 600 @60Hz
4	XGA	1024 x 768 @60Hz
5		1280 x 720 @60Hz
6		1360 x 768 @60Hz
7		1440 x 900 @60Hz
8	SXGA+	1400 x 1050 @60Hz
9	SXGA	1280 x 1024 @60Hz
10	WSXGA+	1680 x 1050 @60Hz
11	SXGA	1280 x 1024 @60Hz
12	HD 1080	1920 x 1080 @60Hz
13	WUXGA	1920 x 1200 @60Hz
14	UXGA	1600 x 1200 @60Hz
15		720 x 480i @59.94Hz
16	HD 1080	1920 x 1080i @60Hz
17		576i @50Hz
24	Output Native Resolution	

User-defined resolutions 18 (Label 1) through 23 (Label 7) can be selected from the resolutions in the following table.

User Defined Resolutions	
Resolution	Resolution
720 x 480 @120Hz	2880 x 480 @60Hz
720 x 480 @240Hz	2880 x 480i @60Hz
720 x 576 @50Hz	2880 x 576 @50Hz
720 x 576 @100Hz	2880 x 576i @50Hz
720 x 576 @200Hz	1920 x 1080 @25Hz
1440 x 576 @50Hz	1920 x 1080 @30Hz
1440 x 576i @50Hz	1920 x 1080 @50Hz
1280 x 720 @50Hz	1920 x 1080i @50Hz
1280 x 720 @60Hz	1920 x 1080 @60Hz
1280 x 720 @100Hz	1920 x 1080i @60Hz
1280 x 720 @120Hz	1920 x 1080i @100Hz
1440 x 288 @50Hz	1920 x 1080i @120Hz
1440 x 480 @60Hz	2K 2048 x 1080 @50Hz
2880 x 240 @60Hz	2K 2048 x 1080 @60Hz
2880 x 288 @50Hz	

The following patterns are supported.

#	Pattern	#	Pattern
1	100% Color bar	17	Square
2	75% Color bar	18	White dot
3	Gray 8	19	Alternate pixels
4	Red screen	20	White HScroll
5	Green screen	21	White VScroll
6	Blue screen	22	Multiburst
7	Yellow screen	23	Horizontal split
8	Cyan screen	24	Vertical split
9	Magenta screen	25	Red ramp
10	Gray 16	26	Green ramp
11	White screen	27	Blue ramp
12	RGB ramp	28	Bounce
13	Crosshatch black	29	Window
14	Crosshatch red	30	White border
15	Crosshatch green	31	Target circle
16	Crosshatch blue	32	Moving ball

The following table shows the output options that are supported.

Parameter	Front Panel	Values
Signal Mode	H/D	HDMI (video, audio and data packet), DVI (video only), Auto
HDCP	HDCP	On, Off
Color Space	CS	RGB, YUV 444, YUV 422, Auto
Color Depth	DC	24 bit, 30 bit, 36 bit, Auto
Audio Sample Rate	ASF	44kHz, 48kHz, 88kHz, 96kHz, 176kHz, 192kHz, Auto
Audio Sample Depth	ASD	16 bit, 20 bit, 24 bit, Auto

6.1 Operating the 840Hxl Using the Front Panel Buttons

To activate the top row of functions (RES, PAT, CS and H/D):

- Press the Function **ON/OFF** button.
The button LED lights

To activate the bottom row of functions (HDCP, DC, ASF and ASD):

- Press the Function **ON/OFF** button again.
The button LED no longer lights

6.1.1 Modifying Operational Parameters

To select a function and modify the value, for example, to select a specific pattern:

1. Press the **Function** button.
The button lights to indicate the top row of functions (ON) is active.
2. Press the **PAT/DC** button.
The button lights to indicate that the Pattern function is active.
3. Press the **+** or **-** button to cycle through the list of available patterns until the required pattern is displayed on the 7-segment display.

Note: The display flashes if there is a problem communicating with the display, for example, if the display does not support HDCP or does not support the selected resolution.

6.1.2 Setting the Delay

To set the delay:

1. Press and hold the **FN** button for a few seconds.
The button flashes and **RES** LED lights.
2. Press the **H/D** key.
The button lights and the 7-segment display indicates the current delay.
3. Press **+** button to increase or the **-** button to decrease the delay.
4. Press the **FN** key to exit the menu.

Note: When the delay is greater than three, the audio parameters interrupt the video.

6.2 Operating the 840HxI Using the Control Application

The **840HxI Control Application** is a PC-based program which lets you program and control the device.

To use the **840HxI Control Application**, download and install the USB driver and the **840HxI Control Application**.

Note: The USB driver is not supported by Windows 64 bit systems.

6.2.1 Downloading and Installing the USB Driver and Control Application

To install the USB driver and Control Application:

1. Navigate to the Kramer Electronics Web site (<http://www.kramerelectronics.com>) and search for the product **840HxI**.
2. Click on the **Downloads** tab.
3. Download the **840HxI** Windows USB Driver.
4. Download the **840HxI Control Application** to a designated folder on your computer.

5. Extract the compressed USB driver file to your designated folder.
Two files are extracted, a **.inf** and a **.sys** file.
6. Connect the USB cable between your computer and the **840Hxl**.
7. Connect the power supply to the **840Hxl**.
8. After a few seconds the **Found New Hardware** message appears as shown in [Figure 4](#).



Figure 4: Found New Hardware Wizard Window

9. Click on the **No, not this time** option button.
10. Click **Next**.
11. Select **Install from a list or specific location (Advanced)** as shown in [Figure 5](#).

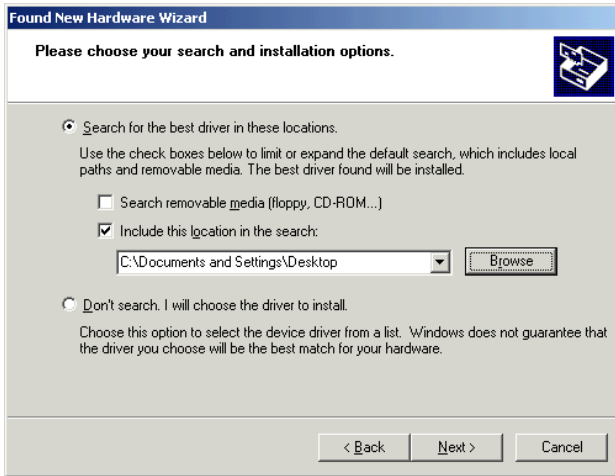

Figure 5: File Location Selection Window

12. Click **Next**.
13. Select **Search for the best driver in these locations**.
14. Check **Include this location in the search**. Browse to your previously designated folder.
15. Click **Next**.
16. Select the file *atm6124.inf*
17. The warning **This driver is not digitally signed!** appears.
18. Click **Next**.
19. Ignore the warning. Click **Continue Anyway**.
20. In the **Insert disk** window, click **OK** as shown in [Figure 6](#).

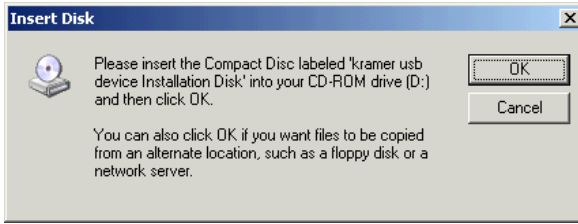

Figure 6: Insert Disk Window

21. Select the file *atm6124.sys* and click **Open**.

The driver installs and a success message is displayed. The USB driver has been successfully installed and you can install the **840Hxl Control Application**.

22. Navigate to the designated folder to which you downloaded the *Control Application*.

23. Double-click the file *setup.exe* from this folder or from the distribution media included with the **840Hxl**.

The *Control Application* has been successfully installed.

6.2.2 Connecting to the Device

To connect to the device:

1. Run the *Control Application* by clicking **Start > Programs > Kramer Electronics > 840Hxl**.
2. Click the **Connect** button.

The **Connection Method** window is displayed as shown in [Figure 7](#).

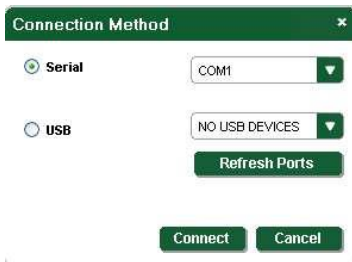

Figure 7: Connection Method Window

3. Select the required connection method (via a serial or USB connection) by clicking the relevant radio button.
4. For a serial connection, select the required Com port from the drop-down list.
5. For a USB connection, select the required USB device from the drop-down list.
To view an up-to-date list of available USB ports, press the **Refresh Ports** button.

Note: If the drop-down list shows **No USB Devices**, then either you have not installed the USB driver (see [Section 5.1.2](#)) or the installation was not successful.

6. Click **Connect**.
If the connection is not successful, a Timeout error message appears as shown in [Figure 8](#). If the connection is successful, the main window shown in [Figure 9](#) appears.



Figure 8: Connection Error Message

6.2.3 Controller Software Main Window

The Controller Software Main Window is shown in [Figure 9](#).

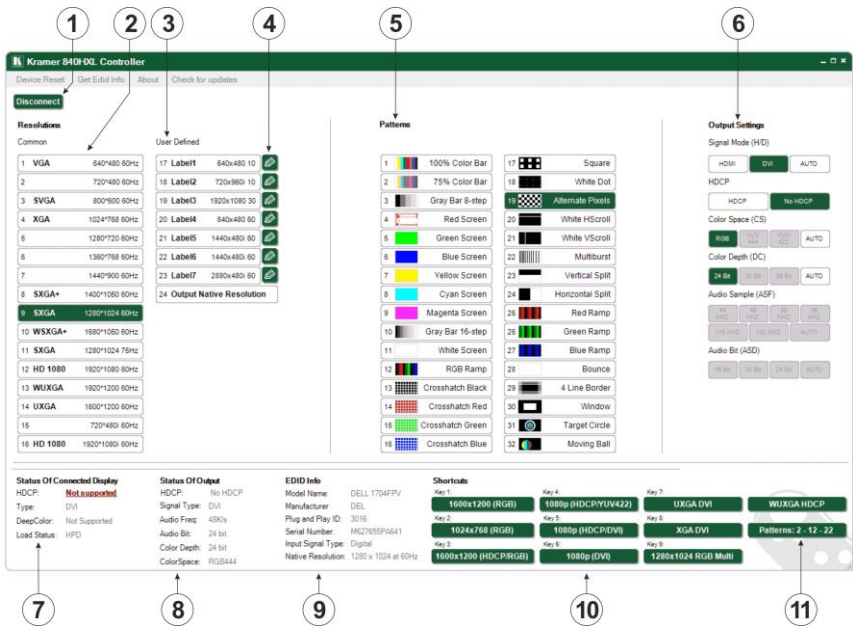

Figure 9: Controller Software Main Window

#	Feature	Function
1	CONNECT Button	Press to connect to a device (see Section 6.2.2)
2	COMMON Resolutions Buttons	Press to select a pre-configured output resolution
3	USER DEFINED Resolutions Buttons	Press to select a user-defined output resolution
4	User Defined Resolution Edit Buttons	Press to edit the relevant user defined output resolution
5	Patterns Buttons	Press to select an output pattern
6	Output Settings Buttons	Press to modify the output settings: Signal Mode—HDMI, DVI, Auto HDCP—HDCP, No HDCP Color Space—RGB, YUV 444, YUV 422, Auto Color Depth—24 bit, 30 bit, 36 bit, Auto Audio Sample Rate—44kHz, 48kHz, 88kHz, 96kHz, 176kHz, 192kHz, Auto Audio Sample Depth—16 bit, 20 bit, 24 bit, Auto
7	Status of Connected Display	Information on the currently connected display. Note: When HDCP is not supported, or there is an HDCP error, the HDCP text is displayed in red
8	Status of Output	Information on the currently selected output settings
9	EDID Info	Click on Get EDID Info from the menu bar to display EDID information from the connected display. If there is no display connected, random data is displayed
10	Shortcuts Buttons	9 Preset buttons, (see following table for details)
11	Patterns: 2 - 12 - 22 Button	Press to cycle through patterns number 2, 12, and 22

The following table describes the parameters stored in the Shortcuts buttons.

Shortcut #	Button Name	Configuration
1	1600x1200 (RGB)	Resolution 22: 1600x1200 Pattern: 14 Type: HDMI HDCP: Off Color: RGB
2	1024x768 (RGB)	Resolution 4: 1024x768 Pattern: 2 Type: HDMI HDCP: Off Color: RGB
3	1280x1024 (RGB)	Resolution 11: 1280x1024 Pattern: 19 Type: HDMI HDCP: Off Color: RGB
4	1080p (HDCP/YUV422)	Resolution 12: 1080p Pattern: 12 Type: HDMI HDCP: On Color: YUV422
5	1080p (HDCP/DVI)	Resolution 12: 1080p Pattern: 12 Type: DVI HDCP: On Color: RGB
6	1080p (DVI)	Resolution 12: 1080p Pattern: 12 Type: DVI HDCP: Off Color : RGB
7	UXGA DVI	Resolution 14: 1600x1200 Pattern: 22 Type: DVI HDCP: Off
8	XGA DVI	Resolution 4: 1024x768 Pattern: 12 Type: DVI HDCP: Off
9	1280x1024 RGB Multi	Resolution 9: 1280x1024 Pattern: 22 Type: DVI HDCP: Off Color: RGB
10	WUXGA HDCP	Resolution 10: 1920x1200 Pattern: 22 Type: HDMI HDCP: On Color: YUV 422

6.2.4 The Menu Bar

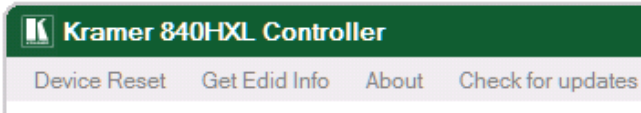

Figure 10: Menu Bar

There are four functions available from the menu bar:

- Device Reset—Resets the device to factory default settings
- Get EDID Info—Reads EDID data from an attached display device
Note: Pressing the F5 button on your keyboard also retrieves the EDID from an attached display
- About—Displays the current software version number, (see [Figure 11](#))
- Check for updates—Checks that the current software version is the latest available



Figure 11: About

6.2.5 Editing User Defined Resolutions

To edit a user defined resolution:

1. Click on one of the user defined resolution edit buttons.
The **User Defined Resolution** Window appears as shown in [Figure 12](#).

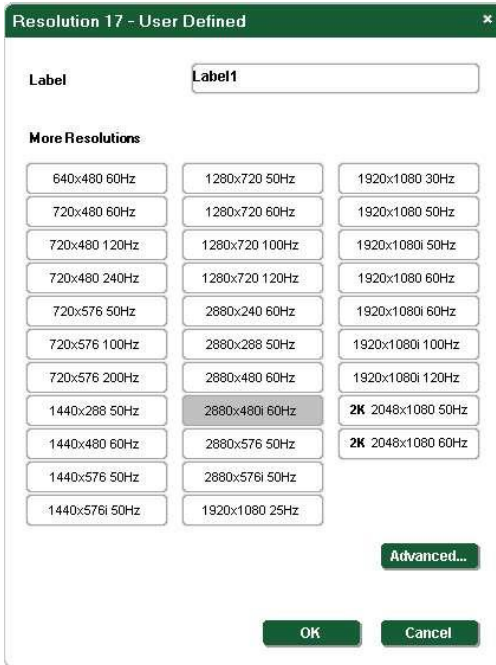

Figure 12: User Defined Resolution Window

2. In the **Label** field, enter the required label for the button.
3. Click on one of the **More Resolutions** buttons to select the required resolution.
4. Click **OK** to save the resolution settings or click the **Advanced** button to edit timing parameters and EDID values.
The **Advanced** Window appears with the **Timing Parameters** tab selected as shown in [Figure 13](#).

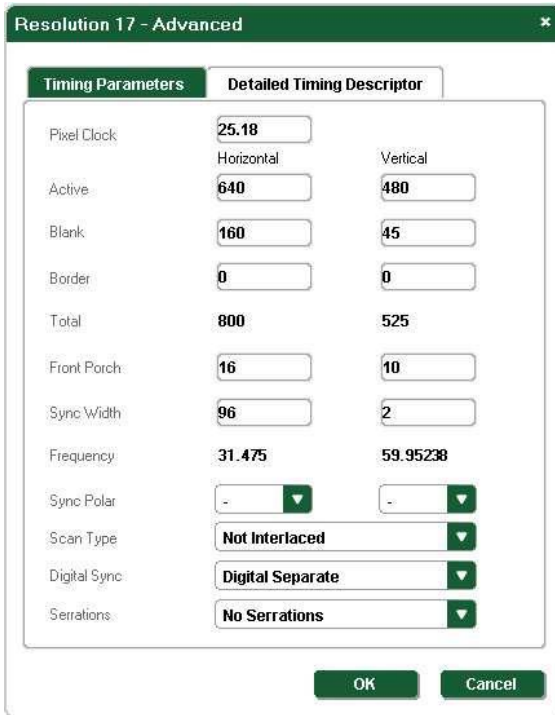

Figure 13: User Defined Resolution Advanced Window

5. Edit or select the required resolution timing values.
6. Click **OK** to accept the changes or click on the **EDID** tab to edit the EDID values as shown in [Figure 14](#).

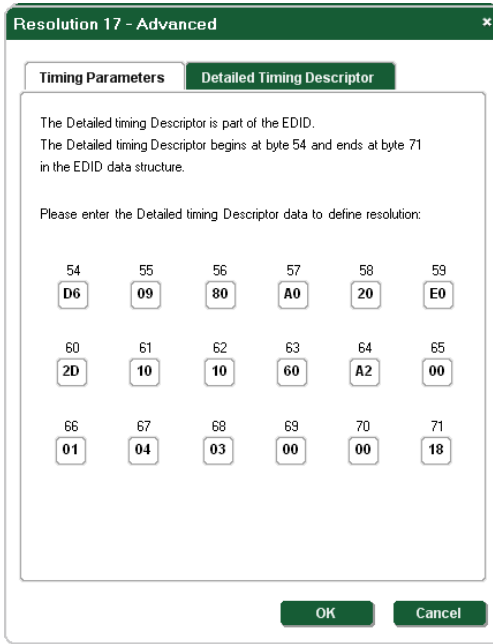

Figure 14: User Defined Resolution Advanced Window–Detailed Timing Descriptor Tab

7. Edit the detailed timing descriptor values as required.
8. Click **OK** to save the values.

6.2.6 To Read EDID Information

To read EDID information:

- Click **Get EDID Info** on the menu bar.
 The EDID of the display connected to the **840HxI** is read and shown under **EDID Info**. If there is no display connected to the **840HxI**, random data is displayed, (see [Figure 9](#)).

7 Technical Specifications

OUTPUT:	1 HDMI connector	
OUTPUT RESOLUTIONS:	VGA 640 x 480 @60Hz	1440 x 576i @50Hz
	720 x 480 @60Hz	1280 x 720 @50Hz
	SVGA 800 x 600 @60Hz	1280 x 720 @60Hz
	XGA 1024 x 768 @60Hz	1280 x 720 @100Hz
	1280 x 720 @60Hz	1280 x 720 @120Hz
	1360 x 768 @60Hz	1440 x 288 @50Hz
	1440 x 900 @60Hz	1440 x 480 @60Hz
	SXGA+ 1400 x 1050 @60Hz	2880 x 240 @60Hz
	SXGA 1280 x 1024 @60Hz	2880 x 288 @50Hz
	WSXGA+ 1680 x 1050 @60Hz	2880 x 480 @60Hz
	SXGA 1280 x 1024 @75Hz	2880 x 480i @60Hz
	HD 1080 1920 x 1080 @60Hz	2880 x 576 @50Hz
	WUXGA 1920 x 1200 @60Hz	2880 x 576i @50Hz
	UXGA 1600 x 1200 @60Hz	1920 x 1080 @25Hz
	720 x 480i @60Hz	1920 x 1080 @30Hz
	HD 1080 1920 x 1080i @60Hz	1920 x 1080 @50Hz
	Output Native Resolution	1920 x 1080i @50Hz
	User Defined	1440 x 576i @50Hz (default)
	User Defined	640 x 480 @60Hz (default)
	User Defined	720 x 480 @60Hz (default)
User Defined	1280 x 720 @60Hz (default)	
User Defined	1920 x 1080i @60Hz (default)	
User Defined	1440 x 480i @60Hz (default)	
User Defined	1440 x 240 @60Hz (default)	
CONTROL:	Five dual-function and two single function front panel buttons, Remote control via USB or RS-232 on a 9-pin D-sub connector	
POWER SOURCE:	5V DC, 460mA	
OPERATING TEMPERATURE:	0° to +40°C (32° to 104°F)	
STORAGE TEMPERATURE:	-40° to +70°C (-40° to 158°F)	
HUMIDITY:	10% to 90%, RHL non-condensing	
DIMENSIONS:	10.7cm x 10.0cm x 4.4cm (4.2" x 3.9" x 1.7") W, D, H	
WEIGHT:	0.4kg (0.88lbs) approx.	
ACCESSORIES:	Power supply	
Specifications are subject to change without notice at http://www.kramerelectronics.com		

8 Serial Protocol

The **840HxI** can be controlled via the serial port using the commands described in this section. The following table shows the default communication parameters.

RS-232	
Baud Rate:	9600
Data Bits:	8
Stop Bits:	1
Parity:	None

8.1 Command Format

Commands must be in the following format:

0xEB, address, command, length of data, data 1, ...data n, checksum

where the following table describes the command components.

Command Component	Description
0xEB	Fixed command start byte
address	Device address. This is always 0x90 for the 840HxI
command	Command to be sent
length of data	How many bytes sent/received (from data 1 to data n)
data 1, data n	One or more command variables within the range 0x01 to 0xFA and excluding 0xEB
checksum	Optional—Checks whether the sending/receiving frame is valid. Check sum = Address + Command + Data length + Data 1+...+Data n For example, EBH, 90H, 01H, 01H, F3H, 85H Check sum = 90H + 01H + 01H + F3H = 185H Note: The checksum gets the low 8 bits, for example, if the check sum = EBH, then check sum = 14H

8.2 Device Response

The device responds as follows:

0xEB, 0x90, command, 0x01, answer, check sum

where *answer* is one of the values described in the following table.

Command Component	Description
0xF1	Either: –the device received the wrong address and returns no response –the device gets information about Errors and Alarms
0xF2	The data is out of range. The command is not executed
0xF3	The device is currently controlled by the buttons. The command is not executed
0xF7	The data length is incorrect. The command is not executed
0xFC	The data is out of range. The command is not executed

8.3 Commands

The commands listed below are supported by the **840HxI**.

Note: A checksum is required at the end of the send/receive command as shown in [Section 8.1](#). If a checksum is not included in a sent command, the device does not respond.

8.3.1 Get Device Address and Software Version

Command	Send/Receive	Data
0x00	0xEB, 0x00, 0x00, 0x01, 0xFF, checksum 0xEB, [address], 0x00, 0x02, [version], 0x00, checksum	0xFF can be any data except 0xEB

8.3.2 Set Output Encryption or Decryption

Command	Send/Receive	Data
0xE3	0xEB, 0x00, 0xE3, 0x01, data 1, checksum 0xEB, address, 0xE3, 0x01, 0xFA, checksum	data 1: <ul style="list-style-type: none"> • 0 = encryption • 1 = decryption

8.3.3 Get Device Status

Command	Send/Receive	Data
0xE4	0xEB, address, 0xE4, 0x01, 0x00, checksum 0xEB, address, 0xE4, 0x08, data1,, data8, checksum	data 1: reserved data 2: reserved data 3: output encryption status: <ul style="list-style-type: none"> • 0 = encryption • 1 = decryption data 4: reserved data 5: reserved data 6: reserved data 7: reserved data 8: reserved

8.3.4 Set Output Status

Command	Send/Receive	Data
0xE6	0xEB, address, 0xE6, 0x02, data1, data2, checksum 0xEB, address, 0xE6, 0x01, 0xFA, checksum	data 1: <ul style="list-style-type: none"> • 0x00: reserved • 0x01: RESOLUTION_INDEX • 0x02: PATTERN_INDEX • 0x03: DEEPCOLOR_MODE • 0x04: COLORSPACE_MODE • 0x05: HDMIDLVL_INDEX • 0x06: AUDSAMPLE_INDEX • 0x07: AUDBIT_INDEX data 2: <ul style="list-style-type: none"> • 0x00 reserved • from 0x00 to 0x17 (24 resolutions) • from 0x00 to 0x1f (32 patterns) • 0 = auto, 0x18 = 24bit, 0x1e = 30bit, 0x24 = 36bit • 0 = auto, 1 = RGB444, 2 = YUV444, 3 = YUV422 • 0 = auto, 1 = HDMI, 2 = DVI • 0 = auto, 1 = 44k, 2 = 48k, 3 = 88k, 4 = 96k, 5 = 176k, 6 = 192k • 0 = auto, 0x10 = 16bit, 0x14 = 20bit, 0x18 = 24bit

8.3.5 Get Output Status

Command	Send/Receive	Data
0xE7	0xEB, address, 0xE7, 0x01, checksum 0xEB, address, 0xE7, 0x0E, data1,... data14, checksum	Data1: FOLLOWENCY_MONITOR; <ul style="list-style-type: none"> • 0 = decryption • 1 = encryption Data2: RESOLUTION_INDEX; <ul style="list-style-type: none"> • from 0x00 to 0x17 (24 resolutions) Data3: PATTERN_INDEX; <ul style="list-style-type: none"> • from 0x00 to 0x1f (32 patterns) Data4: DEEPCOLOR_MODE; <ul style="list-style-type: none"> • 0 = auto • 0x18 = 24bit • 0x1e = 30bit • 0x24 = 36bit Data5: COLORSPACE_MODE; <ul style="list-style-type: none"> • 0 = auto • 1 = RGB444 • 2 = YUV444 • 3 = YUV422 Data6: HDMIDVI_INDEX <ul style="list-style-type: none"> • 0 = auto • 1 = HDMI • 2 = DVI Data7: AUDSAMPLE_INDEX; <ul style="list-style-type: none"> • 0 = auto • 1 = 44k • 2 = 48k • 3 = 88k • 4 = 96k • 5 = 176k • 6 = 192k Data8: AUDBIT_INDEX; <ul style="list-style-type: none"> • 0 = auto • 0x10 = 16bit • 0x14 = 20bit • 0x18 = 24bit

8.3.6 Get Output Status when the Device is in Auto Mode

Command	Send/Receive	Data (Auto Setup)	Data (Not Auto Setup)
0xE7	0xEB, address, 0xE7, 0x01, 0x01, checksum 0xEB, address, 0xE7, 0x08, data1,, data8, checksum	data1: Deep Color: 0x18 (24bit), 0x1E (30bit), 0x24 (36bit)	Setup value
		data2: Color Space: 1 = RGB444, 2 = YUV444, 3 = YUV422	Setup value
		data3: Audio sample: 1 = 44k, 2 = 48k, 3 = 88k, 4 = 96k, 5 = 176k, 6 = 192k	Setup value
		data4: audio bit: 0x10 (16), 0x14 (20), 0x18 (24)	Setup value

8.3.7 Get Monitor Status

Command	Send/Receive	Data
0xE8	0xEB, address, 0xE8, 0x01, 0x00, checksum 0xEB, address, 0xE8, 0x08, data1,, data8, checksum	data1: reserved data2: reserved data3: reserved data4: monitor type (0 = DVI, 1 = HDMI) data5: monitor HDCP status. (0 = no HDCP support, 1 = HDCP supported) data6: monitor Deep Color status (24/30/36) data7: Load status. (0 = no HPD, 1=HPD) data8: reserved

8.3.8 Get Monitor Status

Command	Send/Receive	Data
0xE9	0xEB, address, 0xE9, 0x01, 0x00, checksum 0xEB, address, 0xE9, 0x08, data1,, data8, checksum	data1: monitor Color Space status (0 = RGB, 1 = YUV422, 2 = YUV444, 3 = YUV444+422) data2: reserved data3: reserved data4: reserved data5: reserved data6: reserved data7: reserved data8: reserved

8.3.9 Set Detailed Timing for User-defined Resolution

Command	Send/Receive	Data
0xEA	0xEB, address, 0xEA, 0x26, [block index], [perform immediately], data1H_4bits, data1L_4bits, data2H_4bits, data2L_4bits,, data17H_4bits, data17L_4bits, data18H_4bits, data18L_4bits, checksum 0xEB, address, 0xEA, 0x01, 0xFA, checksum	<p>1. [block index]: From 0 to 7 Note: 7 is the preferred timing of the monitor, so it is preferable to use 0 to 6 2. [perform immediately]: 1 = switch to the user-defined resolution immediately, 0 = save the user-defined resolution but do not switch 3. "H_": high bits 4. "L_": low bits 5. "data nH_4bits" and "data nL_4bits": As, 0xfa apart to 0x0f and 0x0a 6. The 18 data are the detailed timing of the EDID.</p> <p>Example 1: 1600*1200*60 VESA DMT-10 Frame of Command as: EB 90 EA 26 00 00 04 08 03 0F 04 00 03 00 06 02 0B 00 03 02 04 00 04 00 0C 00 01 03 00 00 06 0F 01 03 01 01 00 00 00 00 01 0E (00)</p> <p>Example 2: 720p Frame of Command as: EB 90 EA 26 00 00 00 01 01 0D 00 00 07 02 05 01 0D 00 01 0A 02 00 06 0E 02 08 05 05 00 00 07 0E 08 08 04 02 00 00 00 00 01 0A (00)</p>

8.3.10 Get Detailed Timing for the User-defined Resolution

Command	Send/Receive	Data
0xEA	0xEB, address, 0xEA, 0x01, data1, checksum 0xEB, address, 0xEA, 0x26, block index, 00, data1H_4bits, data1L_4bits, data2H_4bits, data2L_4bits,, data17H_4bits, data17L_4bits, data18H_4bits, data18L_4bits, checksum	data1: From 0 to 7

8.3.11 Setting the Group for Detailed Timing of the User-defined Resolution

Command	Send/Receive	Data
0xEA	0xEB, address, 0xEA, 0x03, data1, data2, data3, checksum 0xEB, address, 0xEA, 0x01, 0xFA, checksum	data1: block index: from 0 to 7 data2: perform immediately: 0 = save the user-defined resolution but do not switch, 1 = switch to the user-defined resolution immediately data3: group number, from 0 to 35

8.3.12 Get the Monitor EDID

Command	Send/Receive	Data
0xFD	0xEB, address, 0xFD, 0x02, 0x03, 0x00, checksum 0xEB, address, 0xFD, 0x12, 0x03, [group num], data1H_4bits, data1L_4bits, data2H_4bits, data2L_4bits,, data7H_4bits, data7L_4bits, data8H_4bits, data8L_4bits, checksum	[group num]: from 0 to 0x3f. Each group has 8 bytes of EDID data When sending the command, there are 64 groups for 512 bytes of EDID data

8.3.13 Reset Device

Command	Send/Receive
0xED	0xEB, address, 0xED, 0x04, 0x03, 0x01, 0x02, 0x07, checksum
	0xEB, address, 0xED, 0x01, 0xFA, checksum

LIMITED WARRANTY

The warranty obligations of Kramer Electronics for this product are limited to the terms set forth below:

What is Covered

This limited warranty covers defects in materials and workmanship in this product.

What is Not Covered

This limited warranty does not cover any damage, deterioration or malfunction resulting from any alteration, modification, improper or unreasonable use or maintenance, misuse, abuse, accident, neglect, exposure to excess moisture, fire, improper packing and shipping (such claims must be presented to the carrier), lightning, power surges, or other acts of nature. This limited warranty does not cover any damage, deterioration or malfunction resulting from the installation or removal of this product from any installation, any unauthorized tampering with this product, any repairs attempted by anyone unauthorized by Kramer Electronics to make such repairs, or any other cause which does not relate directly to a defect in materials and/or workmanship of this product. This limited warranty does not cover cartons, equipment enclosures, cables or accessories used in conjunction with this product.

Without limiting any other exclusion herein, Kramer Electronics does not warrant that the product covered hereby, including, without limitation, the technology and/or integrated circuit(s) included in the product, will not become obsolete or that such items are or will remain compatible with any other product or technology with which the product may be used.

How Long Does this Coverage Last

Seven years as of this printing; please check our Web site for the most current and accurate warranty information.

Who is Covered

Only the original purchaser of this product is covered under this limited warranty. This limited warranty is not transferable to subsequent purchasers or owners of this product.

What Kramer Electronics will do

Kramer Electronics will, at its sole option, provide one of the following three remedies to whatever extent it shall deem necessary to satisfy a proper claim under this limited warranty:

1. Elect to repair or facilitate the repair of any defective parts within a reasonable period of time, free of any charge for the necessary parts and labor to complete the repair and restore this product to its proper operating condition. Kramer Electronics will also pay the shipping costs necessary to return this product once the repair is complete.
2. Replace this product with a direct replacement or with a similar product deemed by Kramer Electronics to perform substantially the same function as the original product.
3. Issue a refund of the original purchase price less depreciation to be determined based on the age of the product at the time remedy is sought under this limited warranty.

What Kramer Electronics will not do Under This Limited Warranty

If this product is returned to Kramer Electronics or the authorized dealer from which it was purchased or any other party authorized to repair Kramer Electronics products, this product must be insured during shipment, with the insurance and shipping charges prepaid by you. If this product is returned uninsured, you assume all risks of loss or damage during shipment. Kramer Electronics will not be responsible for any costs related to the removal or re-installation of this product from or into any installation. Kramer Electronics will not be responsible for any costs related to any setting up this product, any adjustment of user controls or any programming required for a specific installation of this product.

How to Obtain a Remedy under this Limited Warranty

To obtain a remedy under this limited warranty, you must contact either the authorized Kramer Electronics reseller from whom you purchased this product or the Kramer Electronics office nearest you. For a list of authorized Kramer Electronics resellers and/or Kramer Electronics authorized service providers, please visit our web site at www.kramerelectronics.com or contact the Kramer Electronics office nearest you.

In order to pursue any remedy under this limited warranty, you must possess an original, dated receipt as proof of purchase from an authorized Kramer Electronics reseller. If this product is returned under this limited warranty, a return authorization number, obtained from Kramer Electronics, will be required. You may also be directed to an authorized reseller or a person authorized by Kramer Electronics to repair the product.

If it is decided that this product should be returned directly to Kramer Electronics, this product should be properly packed, preferably in the original carton, for shipping. Cartons not bearing a return authorization number will be refused.

Limitation on Liability

THE MAXIMUM LIABILITY OF KRAMER ELECTRONICS UNDER THIS LIMITED WARRANTY SHALL NOT EXCEED THE ACTUAL PURCHASE PRICE PAID FOR THE PRODUCT. TO THE MAXIMUM EXTENT PERMITTED BY LAW, KRAMER ELECTRONICS IS NOT RESPONSIBLE FOR DIRECT, SPECIAL, INCIDENTAL OR CONSEQUENTIAL DAMAGES RESULTING FROM ANY BREACH OF WARRANTY OR CONDITION, OR UNDER ANY OTHER LEGAL THEORY. Some countries, districts or states do not allow the exclusion or limitation of relief, special, incidental, consequential or indirect damages, or the limitation of liability to specified amounts, so the above limitations or exclusions may not apply to you.

Exclusive Remedy

TO THE MAXIMUM EXTENT PERMITTED BY LAW, THIS LIMITED WARRANTY AND THE REMEDIES SET FORTH ABOVE ARE EXCLUSIVE AND IN LIEU OF ALL OTHER WARRANTIES, REMEDIES AND CONDITIONS, WHETHER ORAL OR WRITTEN, EXPRESS OR IMPLIED. TO THE MAXIMUM EXTENT PERMITTED BY LAW, KRAMER ELECTRONICS SPECIFICALLY DISCLAIMS ANY AND ALL IMPLIED WARRANTIES, INCLUDING, WITHOUT LIMITATION, WARRANTIES OF MERCHANTABILITY AND FITNESS FOR A PARTICULAR PURPOSE. IF KRAMER ELECTRONICS CANNOT LAWFULLY DISCLAIM OR EXCLUDE IMPLIED WARRANTIES UNDER APPLICABLE LAW, THEN ALL IMPLIED WARRANTIES COVERING THIS PRODUCT, INCLUDING WARRANTIES OF MERCHANTABILITY AND FITNESS FOR A PARTICULAR PURPOSE, SHALL APPLY TO THIS PRODUCT AS PROVIDED UNDER APPLICABLE LAW.

IF ANY PRODUCT TO WHICH THIS LIMITED WARRANTY APPLIES IS A "CONSUMER PRODUCT" UNDER THE MAGNUSON-MOSS WARRANTY ACT (15 U.S.C.A. §2301, ET SEQ.) OR OTHER APPLICABLE LAW, THE FOREGOING DISCLAIMER OF IMPLIED WARRANTIES SHALL NOT APPLY TO YOU, AND ALL IMPLIED WARRANTIES ON THIS PRODUCT, INCLUDING WARRANTIES OF MERCHANTABILITY AND FITNESS FOR THE PARTICULAR PURPOSE, SHALL APPLY AS PROVIDED UNDER APPLICABLE LAW.

Other Conditions

This limited warranty gives you specific legal rights, and you may have other rights which vary from country to country or state to state.

This limited warranty is void if (i) the label bearing the serial number of this product has been removed or defaced, (ii) the product is not distributed by Kramer Electronics or (iii) this product is not purchased from an authorized Kramer Electronics reseller. If you are unsure whether a reseller is an authorized Kramer Electronics reseller, please visit our Web site at www.kramerelectronics.com or contact a Kramer Electronics office from the list at the end of this document.

Your rights under this limited warranty are not diminished if you do not complete and return the product registration form or complete and submit the online product registration form. Kramer Electronics thanks you for purchasing a Kramer Electronics product. We hope it will give you years of satisfaction.



For the latest information on our products and a list of Kramer distributors, visit our Web site where updates to this user manual may be found.

We welcome your questions, comments, and feedback.

Web site: www.kramerelectronics.com

E-mail: info@kramerel.com

CE



SAFETY WARNING

Disconnect the unit from the power supply before opening and servicing



P/N: 2900-300032



Rev: 7