

HD VIDEO SWITCHER

# V-1HD+

Ver 1.10 and later

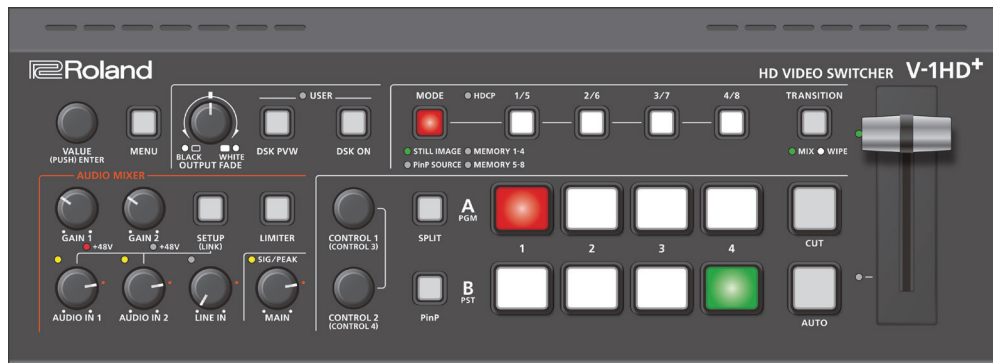

- Roland is an either registered trademark or trademark of Roland Corporation in the United States and/or other countries.
- Company names and product names appearing in this document are registered trademarks or trademarks of their respective owners.

# Contents

<b>Panel Descriptions</b> .....	<b>4</b>	<b>Audio Operations</b> .....	<b>32</b>
Top Panel .....	5	Adjusting the Input Gain (Sensitivity) .....	32
Rear Panel (Connecting Your Equipment) .....	7	Adjusting the Volume Balance .....	33
Side Panel (Connecting Your Equipment) .....	8	Applying Effects to Input Audio .....	34
Multi-View Display .....	9	Applying Effects to Output Audio .....	35
<b>Basic Operations</b> .....	<b>10</b>	Interlinking Audio Output to Video Switching (Audio Follow) .....	36
Turning the Power On/Off .....	10	Checking a Specific Audio Input (Solo) .....	36
Operating the Menu .....	10	Silencing Only Specific Audio (Mute) .....	37
<b>Video Input/Output Settings</b> .....	<b>11</b>	Correcting a Time Difference Between Video and Audio (Delay) .....	37
Setting the Video Input/Output Format .....	11	<b>Other Features</b> .....	<b>38</b>
Setting the System Format .....	11	Saving/Recalling Settings (Preset Memory) .....	38
Setting the Input Format for the INPUT 4 Connector .....	11	Formatting a USB Flash Drive .....	39
Adjusting Output Video .....	12	Backing Up and Restoring the Unit's Settings on a USB Flash Drive ..	40
Adjusting Input Video .....	12	Assigning Different Functions to Control with the [DSK PVW] and [DSK ON] Buttons .....	41
Changing Output Bus Assignments .....	13	Preventing Unintended Operation (Panel Lock) .....	42
Inputting Copy-Protected (HDCP) Video .....	13	Controlling an External Recorder's Video Record Start/Stop from the Unit .....	42
<b>Video Operations</b> .....	<b>14</b>	Returning to the Factory Settings (Factory Reset) .....	43
Switching the Video .....	14	<b>Menu List</b> .....	<b>44</b>
Setting the Operation Mode .....	14	1: VIDEO INPUT .....	44
Switching in the A/B Mode .....	14	2: VIDEO OUTPUT .....	45
Switching in the PGM/PST Mode .....	15	3: TRANSITION TIME .....	45
Changing the Mix/Wipe Pattern .....	16	4: MIX/WIPE .....	45
Changing the Functions of the [CUT] and [AUTO] Buttons .....	17	5: SPLIT .....	46
Switching the Video Automatically (Auto Switching) .....	18	6: PinP .....	47
About the Operation Mode .....	18	7: DSK .....	49
Turning the Auto Switching Function On/Off .....	18	8: AUDIO INPUT .....	50
Setting the Operation Mode .....	18	9: AUDIO OUTPUT .....	54
Loading a Still Image .....	20	10: AUDIO FOLLOW .....	55
Loading a Still Image from a USB Flash Drive .....	20	11: PRESET MEMORY .....	55
Capturing a Still Image from Input Video .....	21	12: CAPTURE IMAGE .....	56
Deleting a Still Image .....	21	13: FREEZE .....	56
Outputting a Loaded Still Image .....	22	14: AUTO SWITCHING .....	57
Assigning Still Images to INPUT 1-4 .....	22	15: USB MEMORY .....	57
Inserting a Still Image in the Final Output .....	22	16: TALLY/RS-232 .....	58
Fading-In/Out the Final Output Video .....	23	17: SYSTEM .....	58
Freezing the Input Video (Freeze) .....	23	<b>RS-232 Command Reference</b> .....	<b>61</b>
<b>Video Composition Operations</b> .....	<b>24</b>	RS-232 Interface .....	61
Compositing Video with Split .....	24	Command Format .....	61
Compositing Video with Picture-in-Picture (PinP) .....	25	List of Commands .....	62
Setting the Operation Mode .....	25	<b>Appendices</b> .....	<b>65</b>
Sending the Inset Screen to Final Output Immediately .....	25	Main Specifications .....	65
Checking the Composited Result for Final Output .....	26	Dimensions .....	67
Making Detailed Settings for the Inset Screen .....	27	Specification of the TALLY Connector .....	67
Key Compositing the Inset Screen .....	28	Video Block Diagram .....	68
Compositing Video with Downstream Keyer (DSK) .....	29	Audio Block Diagram .....	68
Compositing a Logo or Image (Luminance Key) .....	29		
Compositing a Subject and Background (Chroma Key) .....	30		

# Panel Descriptions

## Top Panel

### [OUTPUT FADE] knob (p. 23)

The final output video and audio fade in/out. Rotating the knob counterclockwise fades to black, and rotating the knob clockwise fades to white. The indicators located at the left and right of the [OUTPUT FADE] knob show the status.

<b>Blinking red</b>	Fading in/out
<b>Lit red</b>	Fade-out completed
<b>Unlit</b>	Normal output

### USER (p. 29, 30)

#### [DSK PVW] button

When this is on (lit), it makes the DSK compositing results the preview output.

#### [DSK ON] button

Turns on/off DSK composition.

\* The settings described above are the factory defaults. You can also assign different functions to each button (p. 41). If a different function is assigned, the USER indicator is lit.

### Menu (p. 10)

#### [MENU] button

When this is on (lit), the menu appears on the display that's connected to the OUTPUT 2 connector.

If you're in a lower level, this button returns to the next higher level. If the highest menu level is shown, this button closes the menu.

#### [VALUE] knob

Selects a menu item, or edits the value of a setting. Press this knob to confirm the menu item you selected or the value that you edited.

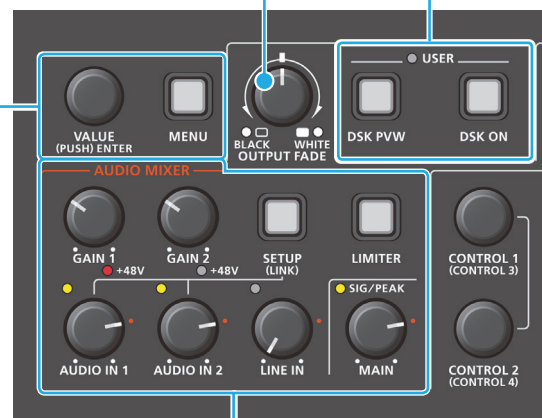

## AUDIO MIXER

### [GAIN 1] [GAIN 2] knobs

Adjusts the input gain (sensitivity) of AUDIO IN 1 or AUDIO IN 2 (p. 32).

### +48V indicators (AUDIO IN 1, 2)

This is lit when phantom power is on.

### [SETUP] button

Accesses the AUDIO INPUT menu.

Long-press this button to turn the stereo link function on/off (p. 32). When this is on (lit), AUDIO IN 1 and 2 are linked, and operate as a stereo channel.

### [AUDIO IN 1] [AUDIO IN 2] [LINE IN] knobs

Adjust the volume of the AUDIO IN 1, AUDIO IN 2, or LINE IN (p. 33).

### SIG/PEAK indicators (AUDIO IN 1, 2/LINE IN)

These are lit green or yellow when audio input is detected. If the input is excessive, the indicator is lit red (p. 32).

### SIG/PEAK indicator (MAIN)

Indicates the overall volume level.

<b>Lit red</b>	Volume is excessive.
<b>Lit yellow</b>	Volume is appropriate.
<b>Lit green</b>	Volume is insufficient.

### [MAIN] knob

Adjusts the overall volume (p. 33).

### [LIMITER] button

Turns the limiter (clipping prevention) on/off. When turned on, the [LIMITER] button is lit green.

**[MODE] button, [1/5]–[4/8] buttons**

Use the [MODE] button to select the function of the [1/5]–[4/8] buttons. An indicator located below the [MODE] button is lit to indicate the current function.

Indicator	Function
STILL IMAGE	Output a still image (p. 22).
PinP SOURCE	When using PinP compositing, select the video source for the inset screen (p. 25, 26).
MEMORY 1–4	Recall the settings saved in a preset memory (1–8).
MEMORY 5–8	Long-press a button to save the current settings in a preset memory (p. 38).

**HDCP indicator (p. 13)**

This indicator is lit, blinking, or unlit according to the HDCP (copy protection) setting and according to whether an HDCP-compliant device is connected.

**[TRANSITION] button (p. 14, 15, 16)**

Selects the video transition effects (MIX, WIPE).

**Video fader (p. 14, 15)**

Manually switch between the videos being input to bus A/PGM and B/PST, and send them to the final output.

**Transition indicators**

The indicator for the final output bus and lights up.

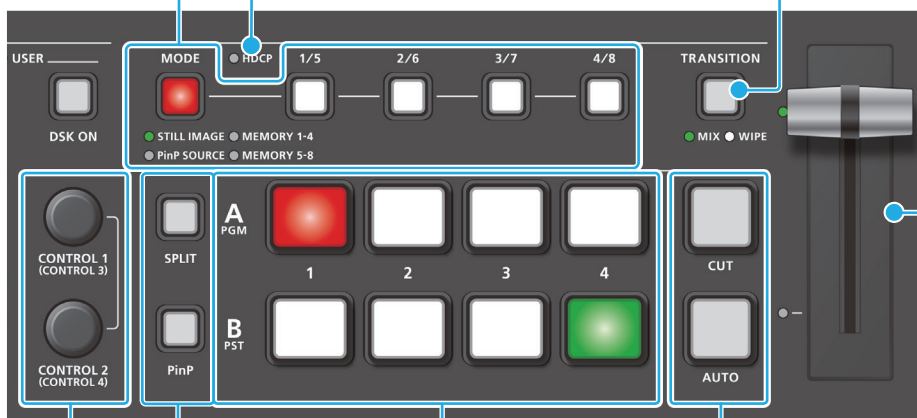

**[SPLIT] [PinP] buttons (p. 24, 25, 26)**

Turns on/off video compositing using split or PinP (picture-in-picture). When turned on, the [SPLIT] or [PinP] button is lit.

**[CUT] [AUTO] buttons (p. 14, 15, 17)**

Automatically switch between the videos being input to bus A/PGM and B/PST, and send them to the final output.

[CUT]	The video switches instantly.
[AUTO]	The video switches with a transition effect applied.

**[CONTROL 1] [CONTROL 2] knobs (p. 24, 25, 26)**

Adjust the split or PinP compositing settings. If you turn a knob while pressing it, these knobs function as [CONTROL 3] [CONTROL 4] knobs.

Knob	Split	PinP
[CONTROL 1]	A-CENTER	POSITION H
[CONTROL 2]	B-CENTER	POSITION V
[CONTROL 3]	CENTER POSITION	SIZE
[CONTROL 4]	SPLIT TYPE	ZOOM

**A/PGM cross-point [1]–[4] buttons**

Selects the video to input to bus A/PGM. The selected button lights up.

**B/PST cross-point [1]–[4] buttons**

Selects the video to input to bus B/PST. The selected button lights up.

## Rear Panel (Connecting Your Equipment)

\* To prevent malfunction and equipment failure, always turn down the volume, and turn off all the units before making any connections.

### DC IN jack

Connect the included AC adaptor to this jack.

- \* Use the cord hook to secure the cord of the AC adaptor as shown in the illustration.

#### Cord hook

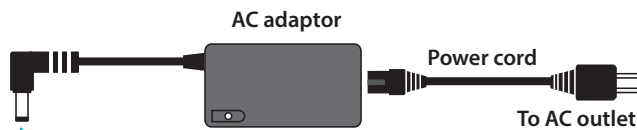
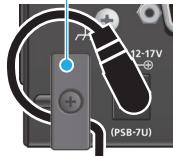

### OUTPUT 1, 2 connectors

These output video. Connect projectors, displays, and recording equipment.

- \* The menu of this unit is shown on the display that's connected to the OUTPUT 2 connector.
- \* For each connector, you can change the output bus (PROGRAM, PREVIEW, MULTI-VIEW) that is assigned.



### RS-232 connector (p. 61)

You can connect this to a computer equipped with an RS-232 connector, and remotely control this unit.

### TALLY connector (p. 67)

This outputs a tally signal. Connect devices provided with a tally-light feature.

### Ground terminal

Connect this to an external earth or ground if necessary.

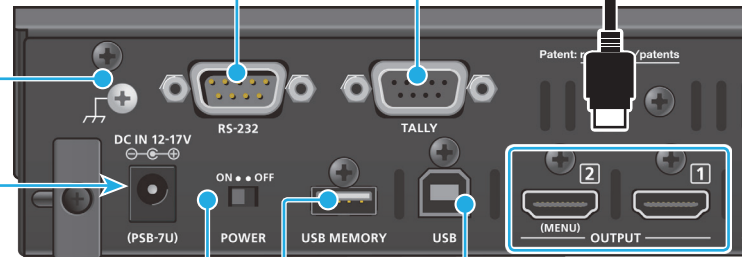

### [POWER] switch (p. 10)

Turns the power on/off.

### USB MEMORY port (p. 20, 40)

Connect a USB flash drive to this port. You use it when importing still images or when saving or loading settings for the unit.



### USB port

This port is used to remotely control this unit from an external device.

\* Do not block the ventilation openings (the slits located on the front and side panels, etc.). If the ventilation openings are blocked, the internal temperatures may rise, causing malfunctions due to excessive heat.

**AUDIO IN 1, 2 jacks/LINE IN L, R jacks**

These input audio. Connect a mic, audio mixer, CD players, or other such audio equipment.

**Phantom power settings**

You can supply phantom power (+48 V) from the AUDIO IN 1 and 2 jacks. Turn on phantom power when you're using a condenser microphone that requires phantom power. Use the [SETUP] button → "AUDIO IN 1" or "AUDIO IN 2" → set "PHANTOM +48V" to "ON." When this is on, the +48V indicator is lit.

**NOTE**

If you don't need phantom power, be sure to turn phantom power off. You risk causing damage if you mistakenly supply phantom power to dynamic microphones, audio playback devices, or other devices that don't require such power.

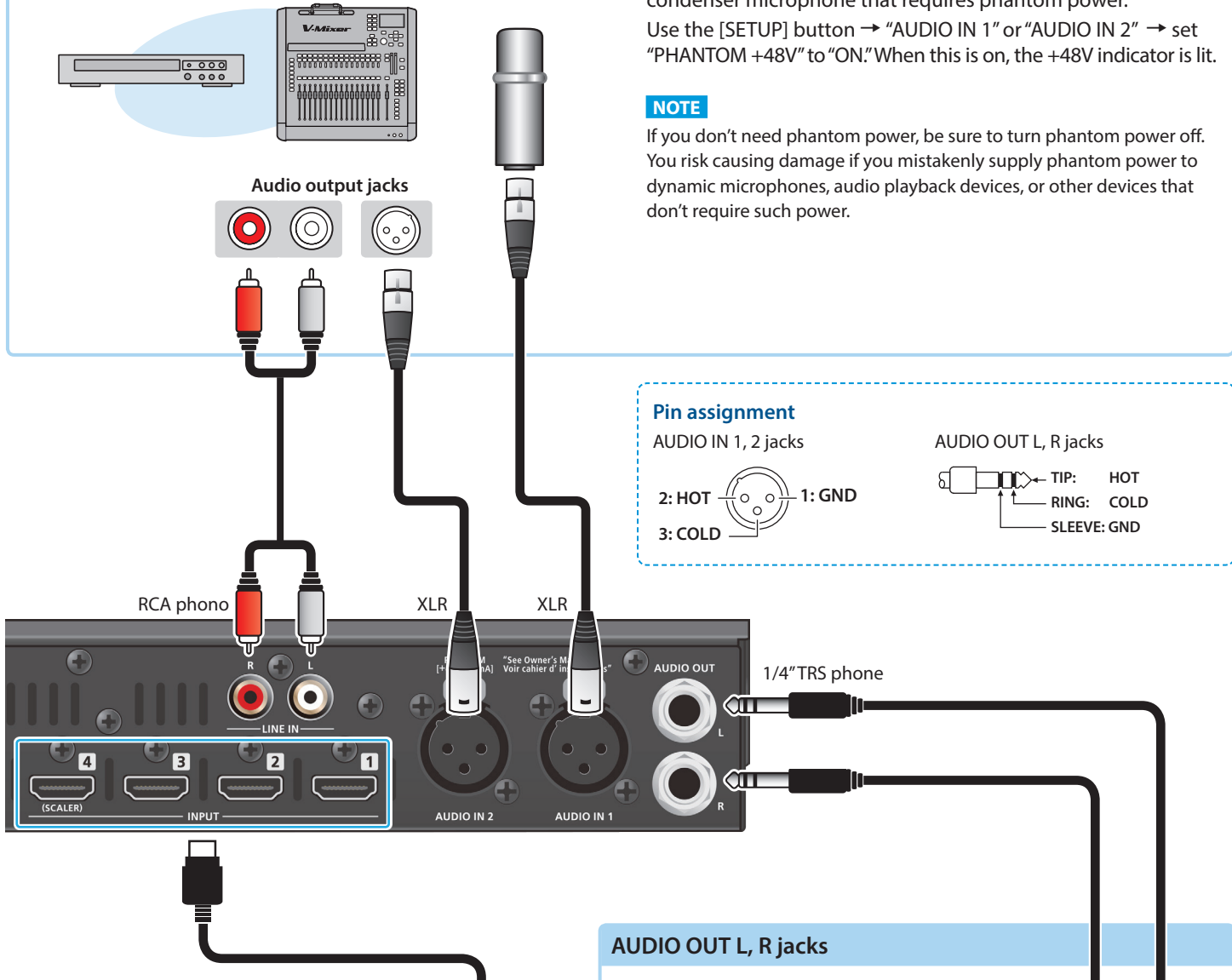

**INPUT 1-4 connectors**

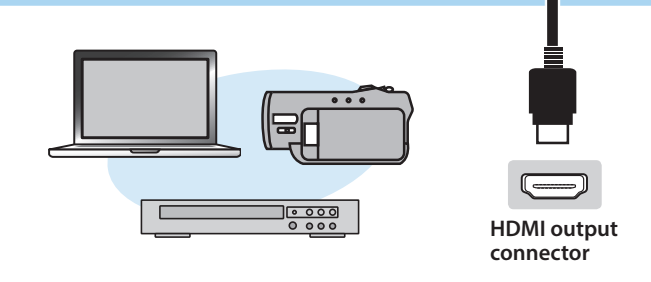

These input video. Connect a video camera, video device such as a BD player, or a computer.

**AUDIO OUT L, R jacks**

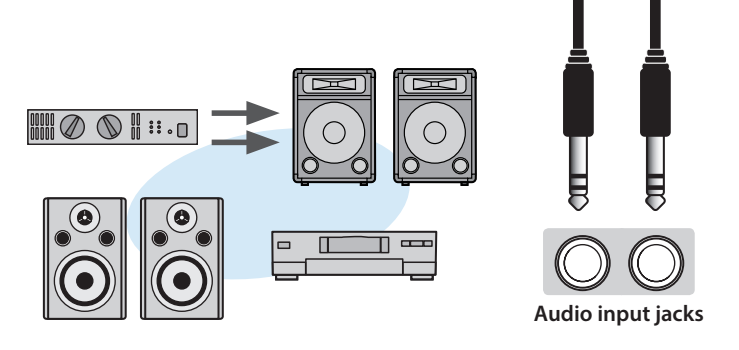

These output the results of audio mixing. Connect an audio recording deck, amplifier, speakers, or other such equipment.

## Side Panel (Connecting Your Equipment)

\* To prevent malfunction and equipment failure, always turn down the volume, and turn off all the units before making any connections.

### MIC/AUX IN jack

This inputs audio. Connect a mic, audio mixer, CD players, or other such audio equipment.

\* Plug-in Power type mics are supported.

### Plug-in Power settings

If you're using a Plug-in Power type mic, turn plug-in power on. Use the [SETUP] button → "MIC/AUX IN" → set "PLUG-IN POWER" to "ON."

### NOTE

When connecting a dynamic mic or a mic that does not support Plug-in Power, be sure to turn Plug-in Power off. If Plug-in Power is on when such a mic is connected, malfunctions will occur.

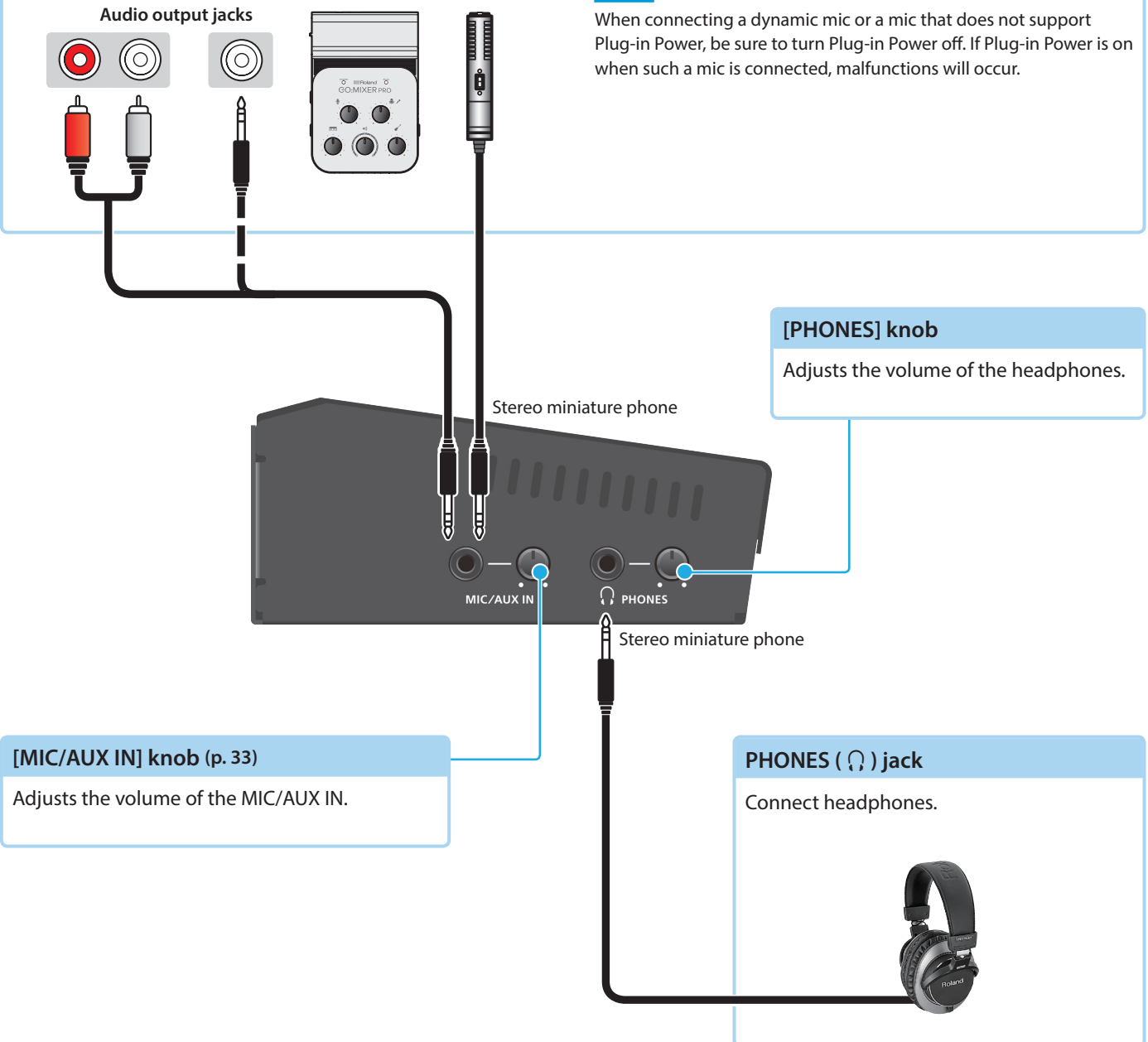

**[PHONES] knob**  
Adjusts the volume of the headphones.

**[MIC/AUX IN] knob (p. 33)**  
Adjusts the volume of the MIC/AUX IN.

**PHONES (🎧) jack**  
Connect headphones.





## Multi-View Display

This unit supports multi-view output. This feature lets you split up the screen into sections and display the final output video, preview video, input video and so on with an external monitor.

The multi-view is output from the OUTPUT 2 connector by factory default.

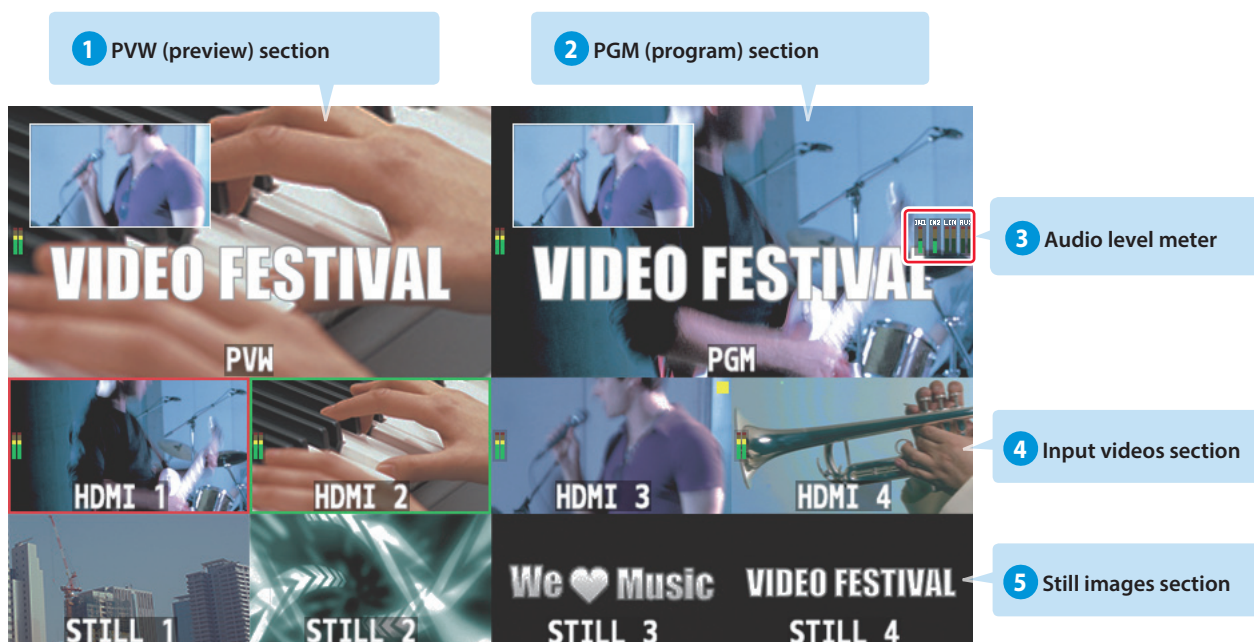

### 1 PVW (preview) section

Displays the preview output video (the video to be output next).

\* The fade-in/out effect (p. 23) is not reflected here.

### 2 PGM (program) section

Displays the final output video.

### 3 Audio level meter

Displays the level meter for audio input from the audio jacks.

### 4 Input videos section

Displays video input via INPUT 1–4 connectors.

The final video output and preview output video (the video to be output next) are displayed with tally frames.

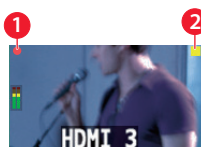

#### 1 REC indicator

If a camera that supports the REC status function is connected, this is shown when the camera's REC button is pressed.

#### 2 PinP indicator

Shows that this has been selected as a video source for PinP compositing.

### 5 Still images section

Shows the loaded still images (p. 20, 21).



Yellow	<b>PinP indicator</b> Shows that this has been selected as a video source for PinP compositing.
Red	<b>STILL indicator</b> Shows that a still image is being output. * Only when pressing the [1/5]–[4/8] buttons and outputting a still image (p. 22).

### Audio level meter indication

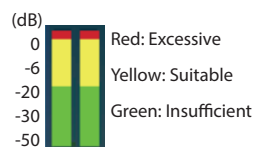

The following status marks are shown below the level meter.

MT	The mute function (p. 37) is on.
A.F	The audio follow function (p. 36) is on.

#### MEMO

- For details on the cameras that support the REC status function, refer to the Roland website.  
<https://proav.roland.com/>
- The menu is shown on the monitor that's connected to the OUTPUT 2 connector.

# Basic Operations

## Turning the Power On/Off

Once everything is properly connected, be sure to follow the procedure below to turn on their power. If you turn on equipment in the wrong order, you risk causing malfunction or equipment failure.

\* Before turning the unit on/off, always be sure to turn the volume down. Even with the volume turned down, you might hear some sound when switching the unit on/off. However, this is normal and does not indicate a malfunction.

## Turning the power on

\* If still images are saved on the unit (p. 20), startup takes longer time according to image size and the number of still images saved.

1. Make sure that all devices are powered-off.
2. Turn on this unit's [POWER] switch.

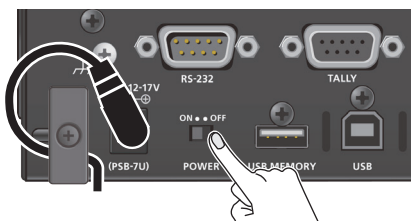

3. Turn on the power in the order of source devices → output devices.

## Turning the power off

1. Turn off the power in the order of output devices → source devices.
2. Turn off this unit's [POWER] switch.

### About the Auto Off function

The power to the unit turns off automatically when all of the following states persist for 240 minutes (Auto Off function).

- No operation performed on the unit
- No audio or video input
- No equipment is connected to the OUTPUT 1 and 2 connectors

If you do not want the power to be turned off automatically, disengage the Auto Off function.

Use the [MENU] button → "SYSTEM" → set "AUTO OFF" to "OFF"

\* Unsaved data is lost when the power turns off. Before turning the power off, save the data that you want to keep.

\* To restore power, turn the power on again.

## Operating the Menu

Here's how to access the menu, and make video/audio settings and settings for this unit.

The menu is shown on the monitor that's connected to the OUTPUT 2 connector.

1. Press the [MENU] button to display the menu.

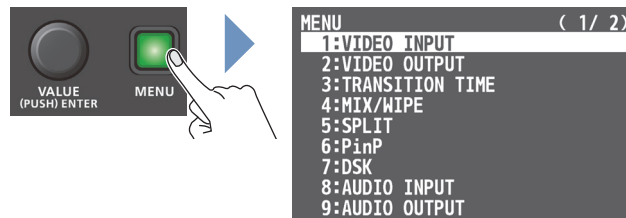

The menu is organized into functions.

2. Turn the [VALUE] knob to select the menu item that you want to edit, and press the [VALUE] knob to confirm.

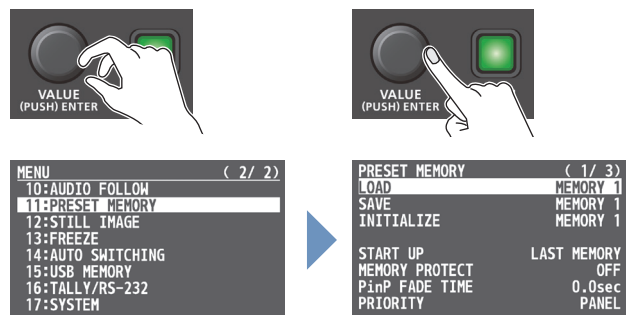

3. Repeat step 2 as needed.

Pressing the [MENU] button moves you back one level higher.

4. Turn the [VALUE] knob to change the setting value, and then press the [VALUE] knob to confirm.

- By turning the [VALUE] knob while pressing it, you can change the value more greatly.
- Long-pressing the [VALUE] knob returns the current menu item you're setting to its default value.

5. Press the [MENU] button several times to close the menu.

### MEMO

The [SETUP] button is a shortcut button used to display the AUDIO INPUT menu.

# Video Input/Output Settings

## Setting the Video Input/Output Format

Here's how to specify the input/output format as appropriate for the device that's connected.

### Setting the System Format

On this unit, the input/output format is determined according to the system format. You set the input/output format to match the connected equipment.

System format	Input format (*1)	Output format
	INPUT 1-3 connectors	OUTPUT 1 and 2 connectors
1080p	1080p, 1080i	1080p
1080i	1080p, 1080i	1080i
720p	720p	720p

(\*1) You can specify separate individual input formats for the INPUT 4 connector, regardless of the system format.  
For details, refer to "Setting the Input Format for the INPUT 4 Connector" on this page.

1. [MENU] button → "SYSTEM" → select "SYSTEM FORMAT," and press the [VALUE] knob.

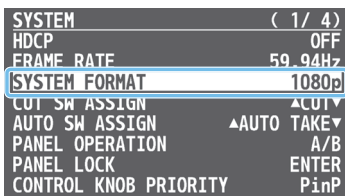

2. Use the [VALUE] knob to select "1080p," "1080i," or "720p," and press the [VALUE] knob to confirm.

\* A change in the setting is not applied until you press the [VALUE] knob to confirm.

3. Press the [MENU] button several times to close the menu.

### Internal processing

The unit's internal processing is progressive. Interlaced input video is automatically converted to a progressive signal.

The video might appear jagged at this time, or the video in a PinP inset screen or on the multi-view might waver.

This is due to progressive conversion, and is not a malfunction.

### About frame rate

The frame rates "59.94 Hz" and "50 Hz" are supported for input and output video.

To make this setting, use the [MENU] button → "SYSTEM" → "FRAME RATE."

### Setting the Input Format for the INPUT 4 Connector

With the factory settings, the EDID assignment for the INPUT 4 connector is "INTERNAL" (set so that EDID values of all inputtable formats are sent).

To specify an input format of your choice, change the setting of the EDID information being sent so that it matches the incoming video signal.

#### What is EDID?

EDID is data that is transmitted from the unit to the source device when the unit is connected to a source device. EDID contains data such as the formats that can be input to the unit (resolution, color space, color depth) and audio information. Based on the EDID information that the source device receives, it will output the most appropriate video format to the unit.

1. [MENU] button → "VIDEO INPUT" → "INPUT 4 (SCALER)" → select "EDID," and press the [VALUE] knob.

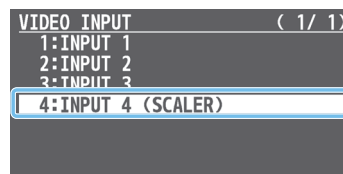

2. Use the [VALUE] knob to select "EDID," and press the [VALUE] knob.

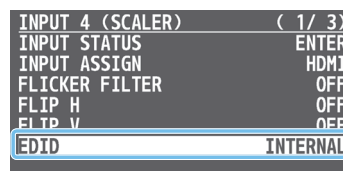

3. Use the [VALUE] knob to set the input format (the EDID information to send), and press the [VALUE] knob to confirm.

\* A change in the setting is not applied until you press the [VALUE] knob to confirm.

Value	
INTERNAL (EDID information for all inputtable formats is sent.)	
SXGA+ (1400 x 1050)	UXGA (1600 x 1200)
SVGA (800 x 600)	WUXGA (1920 x 1200)
XGA (1024 x 768)	720p
WXGA (1280 x 800)	1080i
FWXGA (1366 x 768)	1080p
SXGA (1280 x 1024)	

4. Press the [MENU] button several times to close the menu.

## Adjusting Output Video

Here's how to adjust the output image appropriately for the device that's receiving the unit's output.

1. [MENU] button → "VIDEO OUTPUT" → select "OUTPUT 1" or "OUTPUT 2," and press the [VALUE] knob.

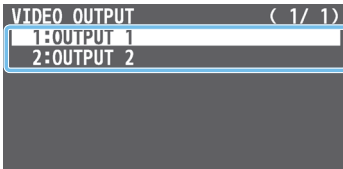

2. Use the [VALUE] knob to select a menu item, and press the [VALUE] knob.

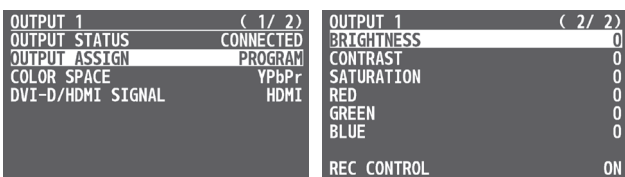

Menu item	Explanation
OUTPUT STATUS	Shows the connection status of the OUTPUT connector.
OUTPUT ASSIGN	Specifies the output bus that is assigned to the OUTPUT connector (p. 13).
COLOR SPACE	Specifies the color space (system for representing colors in video).
DVI-D/HDMI SIGNAL	Specifies the type of output signal.
BRIGHTNESS	Adjusts the brightness.
CONTRAST	Adjusts the contrast.
SATURATION	Adjusts the saturation.
RED	Adjusts the red level.
GREEN	Adjusts the green level.
BLUE	Adjusts the blue level.

3. Use the [VALUE] knob to edit the value of the setting.
4. Press the [MENU] button several times to close the menu.

### MEMO

You can output a test pattern, useful for adjusting the image quality of a display.  
Use the [MENU] button → "SYSTEM" → "TEST PATTERN" to select the type of test pattern that will be output.

## Adjusting Input Video

Here's how to adjust the quality of the input video signals. For the INPUT 4 connector, you can also adjust the scaling.

1. [MENU] button → "VIDEO INPUT" → select "INPUT 1"–"OUTPUT 4 (SCALER)," and press the [VALUE] knob.

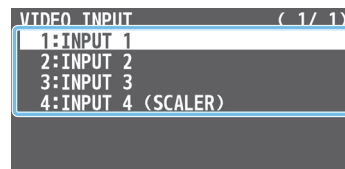

2. Use the [VALUE] knob to select a menu item, and press the [VALUE] knob.

### INPUT 1-3, INPUT 4 (SCALER)



Menu item	Explanation
INPUT STATUS	Displays information about the incoming video.
INPUT ASSIGN	Selects the video source (p. 22).
FLIP H	If this is "ON," the video is input with left and right flipped.
FLIP V	If this is "ON," the video is input with top and bottom flipped.
BRIGHTNESS	Adjusts the brightness.
CONTRAST	Adjusts the contrast.
SATURATION	Adjusts the saturation.

### INPUT 4 (SCALER)

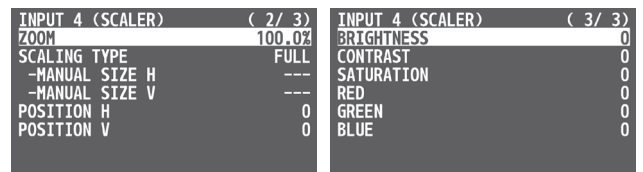

Menu item	Explanation
FLICKER FILTER	If this is "ON," flickering is reduced.
EDID	Specifies the input format (EDID) (p. 11).
ZOOM	Adjusts the zoom ratio.
SCALING TYPE	Specifies the scaling type.
MANUAL SIZE H	Adjusts the horizontal size when scaling type is set to "MANUAL."
MANUAL SIZE V	Adjusts the vertical size when scaling type is set to "MANUAL."
POSITION H	Adjusts the position in the horizontal direction.
POSITION V	Adjusts the position in the vertical direction.
RED	Adjusts the red level.
GREEN	Adjusts the green level.
BLUE	Adjusts the blue level.

3. Use the [VALUE] knob to edit the value of the setting.
4. Press the [MENU] button several times to close the menu.

## Changing Output Bus Assignments

This unit provides three output buses: PROGRAM, PREVIEW, and MULTI-VIEW. You can assign the output bus of your choice to each of the OUTPUT 1 and OUTPUT 2 connectors.

Output bus	Explanation
PROGRAM	Outputs the video that reflects all processing such as video compositing that has been applied (the final output video).
PREVIEW	Outputs the video that has been processed up to video compositing (the preview output video). The fade-in/out effect (p. 23) is not reflected here.
MULTI-VIEW	Outputs a multi-view.

1. [MENU] button → “VIDEO OUTPUT” → select “OUTPUT 1” or “OUTPUT 2,” and press the [VALUE] knob.

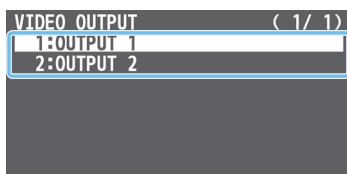

2. Use the [VALUE] knob to select “OUTPUT ASSIGN,” and press the [VALUE] knob.

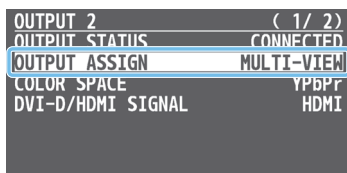

3. Use the [VALUE] knob to select the output bus.
4. Press the [MENU] button several times to close the menu.

### MEMO

When outputting a multi-view from the OUTPUT 1 jack, the tally frame, audio level meter, label, menu and other screen elements are not displayed.

## Inputting Copy-Protected (HDCP) Video

If you want to input HDCP-protected video from a BD player or other device, you can enable HDCP input.

\* If you want to output copy-protected (HDCP) video or audio, connect a device that supports HDCP.

### What's HDCP?

HDCP is copyright-protection technology that prevents unlawful copying of content by encoding the path when sending digital signals from a video playback device to a display monitor or other display equipment.

1. [MENU] button → “SYSTEM” → select “HDCP,” and press the [VALUE] knob.

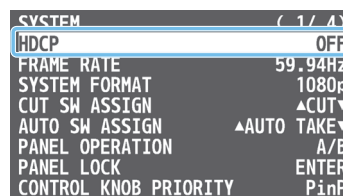

2. Use the [VALUE] knob to select “ON,” and press the [VALUE] knob to confirm.

Value	Explanation
ON	HDCP-protected video can be input. HDCP is also added to the video that is output.
OFF	HDCP-protected video cannot be input.

\* A change in the setting is not applied until you press the [VALUE] knob to confirm.

3. Press the [MENU] button several times to close the menu.

## Checking for HDCP-capable devices

### Source devices

You can check the HDCP support status of the source device from the menu.

Use the [MENU] button → “INPUT 1”–“INPUT 4 (SCALER)” → “INPUT STATUS” to display the HDCP status.

When inputting copy-protected (HDCP) video, “DETECT” is displayed.

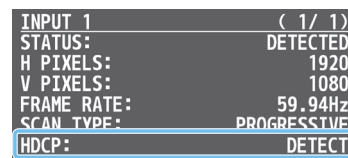

### Output devices

The HDCP indicator shows whether the output device is HDCP-capable.



Indicator	HDCP	Connection status
Lit	ON	An HDCP-capable device is connected to one of the OUTPUT connectors.
Blinking	ON	An HDCP-capable device is not connected to an OUTPUT connector. Alternatively, a device that is not HDCP capable is connected to one of the OUTPUT connectors.
Unlit	OFF	—

# Video Operations

## Switching the Video

You can switch between the videos of the A/PGM bus and B/PST bus to specify the final output.

### Setting the Operation Mode

There are two operation modes for switching the video: the "A/B mode" and the "PGM/PST mode."

Video on the A/PGM bus

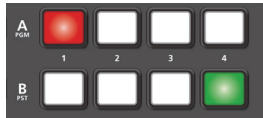

Video on the B/PST bus

#### A/B mode (factory settings)

When you operate the video fader, the video of the bus toward which you slide the video fader becomes the final output.

The video of the other bus becomes the preview output video (the video that is output next).

When the [CUT] or [AUTO] button is operated, the video on the A/PGM bus and the video on the B/PST bus become the final output in alternation.

#### PGM/PST mode

The video on the A/PGM bus is always the final output.

The video on the B/PST bus is preview output video (the video to be output next).

Operating the video fader or the [CUT] or [AUTO] button makes the final video output and the preview output video change places.

1. Press the [MENU] button → "SYSTEM" → select "PANEL OPERATION," and press the [VALUE] knob.

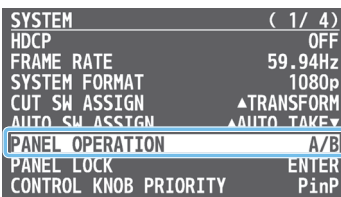

2. Turn the [VALUE] knob to select "A/B" or "PGM/PST"
3. Press the [MENU] button several times to close the menu.

### Switching in the A/B Mode

Here are the steps when selecting "A/B mode" in the operation mode settings.

For more details on the operation modes, see "Setting the Operation Mode" on this page.

1. Slide the video fader all the way to the top or bottom.



The video of the bus toward which you slide the video fader becomes the final output.

2. To select the preview output video (the video that is output next), press a cross-point [1]–[4] button that is on the opposite side as the direction in which you slid the video fader.

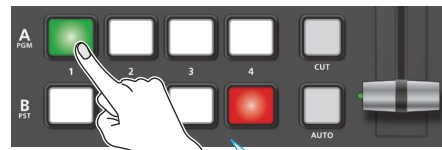

Lit red: Final output video  
Lit Green: Preview output video (the video to be output next)

3. Press the [TRANSITION] button to select the transition effect (MIX, WIPE).



#### Mix

The two videos are mixed as the transition occurs.



#### Wipe

The next video moves across to replace the original video.



<Using the buttons to switch>

4. Press the [AUTO] or [CUT] button.

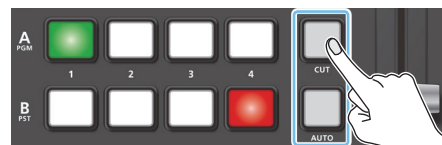

Button	Explanation
[CUT]	The picture switches instantly.
[AUTO]	A transition effect is applied and the video is switched automatically. The [AUTO] button flashes while the video transition is in progress.

<Using the fader to switch>

- Slide the video fader in the direction opposite to the direction in step 1.

The transition indicator for the video that is the final output is lit.

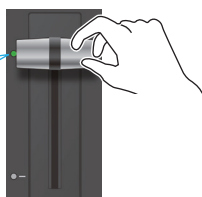

The video is switched according to the movement of the video fader.

**MEMO**

- Video transition time**  
If you use the [AUTO] button to switch video, the transition occurs over a pre-specified time.  
To specify the video transition time, use the [MENU] button → "TRANSITION TIME" → "MIX/WIPE TIME."
- Video transition effects**  
You can change the transition pattern used for a wipe or mix transition.  
→ "Changing the Mix/Wipe Pattern" (p. 16)
- Functions of the [CUT] and [AUTO] buttons**  
You can change what happens when you press the [CUT] and [AUTO] buttons.  
→ "Changing the Functions of the [CUT] and [AUTO] Buttons" (p. 17)
- When you use the [AUTO] or [CUT] button to switch video, the actual output might come to differ from the position of the video fader.  
If you operate the video fader in this state, the output does not change until the position of the video fader matches the actual output.

## Switching in the PGM/PST Mode

Here are the steps when selecting "PGM/PST mode" in the operation mode settings.

For more details on the operation modes, see "Setting the Operation Mode" (p. 14).

- Slide the video fader all the way to the top or bottom.



The video on the A/PGM bus is the final output.

- Press a B/PST cross-point [1]–[4] button to select the preview output video (the video to be output next).

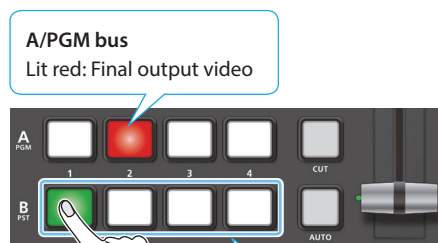

**A/PGM bus**  
Lit red: Final output video

**B/PST bus**  
Lit Green: Preview output video (the video to be output next)

- Press the [TRANSITION] button to select the transition effect (MIX, WIPE).



**Mix**  
The two videos are mixed as the transition occurs.



**Wipe**  
The next video moves across to replace the original video.



<Using the buttons to switch>

- Press the [AUTO] or [CUT] button.



Button	Explanation
[CUT]	The picture switches instantly.
[AUTO]	A transition effect is applied and the video is switched automatically. The [AUTO] button flashes while the video transition is in progress.

<Using the fader to switch>

- Slide the video fader in the direction opposite to the direction in step 1.

The transition indicator on the bus side where you slid the fader lights up.

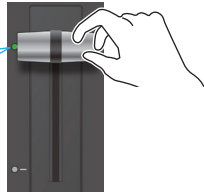

The video is switched according to the movement of the video fader.

**MEMO**

**Video transition time**

If you use the [AUTO] button to switch video, the transition occurs over a pre-specified time.  
To specify the video transition time, use the [MENU] button → "TRANSITION TIME" → "MIX/WIPE TIME."

**Video transition effects**

You can change the transition pattern used for a wipe or mix transition.  
→ "Changing the Mix/Wipe Pattern" (p. 16)

- When you use the [AUTO] or [CUT] button to switch video, the actual output might come to differ from the position of the video fader.  
If you operate the video fader in this state, the output does not change until the position of the video fader matches the actual output.

## Changing the Mix/Wipe Pattern

You can change the transition pattern by which the mix/wipe occurs and the direction of the wipe.

- [MENU] button → select "MIX/WIPE," and press the [VALUE] knob.

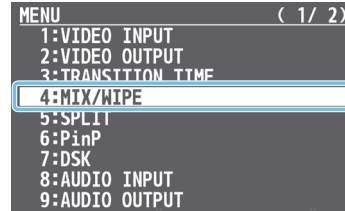

- Use the [VALUE] knob to select a menu item, and press the [VALUE] knob.

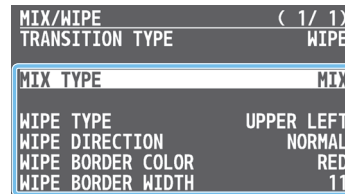

Menu item	Explanation
MIX TYPE	Specifies the transition pattern for mix.
WIPE TYPE	Specifies the transition pattern for wipe.
WIPE DIRECTION	Specifies the direction of wipe.
WIPE BORDER COLOR	Specifies the color of the border added to the edge of the wipe area.
WIPE BORDER WIDTH	Specifies the width of the border added to the edge of the wipe area.

- Use the [VALUE] knob to change the value of the setting.
- Press the [MENU] button several times to close the menu.

**MEMO**

You can change the settings of the MIX/WIPE menu by holding down the [TRANSITION] button and turning the [CONTROL 1] or [CONTROL 2] knob.

\* If you turn the [CONTROL 1] [CONTROL 2] knobs while pressing it, these knobs function as [CONTROL 3] [CONTROL 4] knobs.

**When mix is selected**

Operation	Explanation
[TRANSITION] + [CONTROL 1]	MIX TYPE

**When wipe is selected**

Operation	Explanation
[TRANSITION] + [CONTROL 1]	WIPE TYPE
[TRANSITION] + [CONTROL 2]	WIPE DIRECTION
[TRANSITION] + [CONTROL 3]	WIPE BORDER COLOR
[TRANSITION] + [CONTROL 4]	WIPE BORDER WIDTH



## Changing the Functions of the [CUT] and [AUTO] Buttons

You can change what happens when you press the [CUT] and [AUTO] buttons.

\* In PGM/PST mode (p. 15), the functions of the [CUT] and [AUTO] buttons are fixed.

1. [MENU] button → “SYSTEM” → select “CUT SW ASSIGN” or “AUTO SW ASSIGN,” and press the [VALUE] knob.

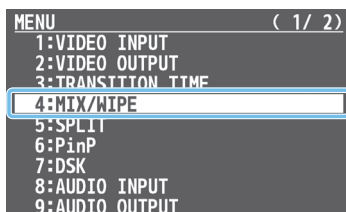

2. Use the [VALUE] knob to select a function of the button.

Value	Explanation
<b>CUT SW ASSIGN</b>	
▲AUTO TAKE	When the video of the B/PST bus is selected, switches to the video of the A/PGM bus.
▲AUTO TAKE▼	Switches the video between A/PGM bus and B/PST bus.
▲CUT	When the video of the B/PST bus is selected, switches to the video of the A/PGM bus as a cut.
▲CUT▼	Switches the video between A/PGM bus and B/PST bus as a cut.
▲TRANSFORM	When the video of the B/PST bus is selected, switches to the video of the A/PGM bus as a cut only while you're holding down the button.
<b>AUTO SW ASSIGN</b>	
AUTO TAKE▼	When the video of the A/PGM bus is selected, switches to the video of the B/PST bus.
▲AUTO TAKE▼	Switches the video between A/PGM bus and B/PST bus.
CUT▼	When the video of the A/PGM bus is selected, switches to the video of the B/PST bus as a cut.
▲CUT▼	Switches the video between A/PGM bus and B/PST bus as a cut.
TRANSFORM▼	When the video of the A/PGM bus is selected, switches to the video of the B/PST bus as a cut only while you're holding down the button.

3. Press the [MENU] button several times to close the menu.

## Switching the Video Automatically (Auto Switching)

The video of INPUT 1–4 or of preset memories (p. 38) can be switched automatically (the auto switching function).

\* You can make operation easier by letting the video switch automatically.

### About the Operation Mode

Auto switching provides three operation modes that you can select as appropriate for your situation: “input scan,” “preset memory scan,” and “BPM sync.”

#### Switching at a specified interval (Input scan)

This automatically switches the INPUT 1–4 video when a specified length of time elapses. You can change the duration that each video is shown, and also switch randomly between videos.

This is convenient when you want to switch between video signals of multiple cameras, for example when live-streaming a singer-instrumentalist.

\* If there is no video input, this is skipped.

#### Switching preset memories (Preset memory scan)

This automatically switches between preset memories 1–8. The video and audio are switched according to the settings that are saved in each preset memory.

\* Preset memories in which no settings have been saved are skipped.

#### Switching in synchronization with the BPM (BPM sync)

This automatically switches the video at specified BPM intervals. This lets you create video transitions that are synchronized with the music, for example when live-streaming a DJ performance or a musical performance.

### Turning the Auto Switching Function On/Off

1. [MENU] button → select “AUTO SWITCHING,” and press the [VALUE] knob.

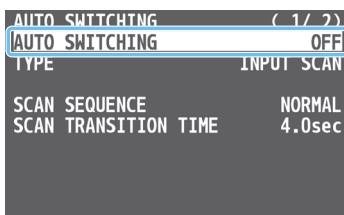

2. Turn the [VALUE] knob to select “ON” or “OFF.”
3. Press the [MENU] button several times to close the menu.

### Setting the Operation Mode

#### Input scan

1. [MENU] button → “AUTO SWITCHING” → select “TYPE,” and press the [VALUE] knob.

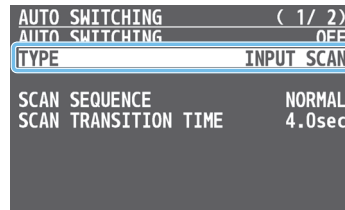

2. Use the [VALUE] knob to select “INPUT SCAN,” and press the [VALUE] knob.
3. Use the [VALUE] knob to select a menu item, and press the [VALUE] knob.

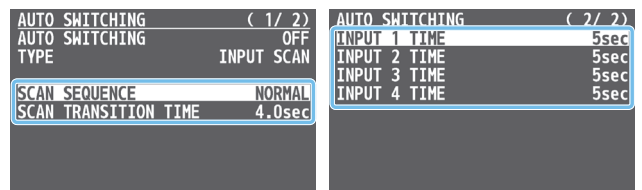

Menu item	Explanation
SCAN SEQUENCE	Specifies the order in which video signals are shown.  <b>NORMAL:</b> Switches in the order of INPUT 1 → 4.  <b>REVERSE:</b> Switches in the order of INPUT 4 → 1.  <b>RANDOM:</b> Switches randomly.
SCAN TRANSITION TIME	Specifies the video transition time.
INPUT 1–4 TIME	Specifies the time that the video is shown. Turn this “OFF” to skip.

4. Use the [VALUE] knob to change the value of the setting.
5. Press the [MENU] button several times to close the menu.

**Preset memory scan**

1. [MENU] button → “AUTO SWITCHING” → select “TYPE,” and press the [VALUE] knob.

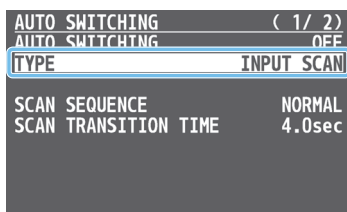

2. Use the [VALUE] knob to select “PRESET MEMORY SCAN,” and press the [VALUE] knob.
3. Use the [VALUE] knob to select a menu item, and press the [VALUE] knob.

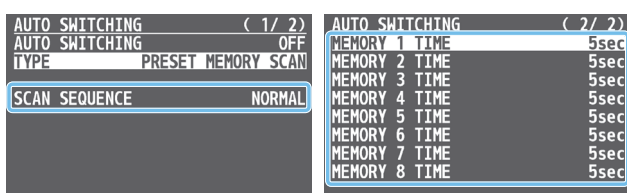

Menu item	Explanation
SCAN SEQUENCE	Specifies the order in which preset memories are switched.
	<b>NORMAL:</b> Switches in the order of preset memory 1 → 8.
	<b>REVERSE:</b> Switches in the order of preset memory 8 → 1.
	<b>RANDOM:</b> Switches randomly.
MEMORY 1–8 TIME	Specifies the time it takes to switch to the next preset memory. Turn this “OFF” to skip.

4. Use the [VALUE] knob to change the value of the setting.
5. Press the [MENU] button several times to close the menu.

**BPM sync**

1. [MENU] button → “AUTO SWITCHING” → select “TYPE,” and press the [VALUE] knob.

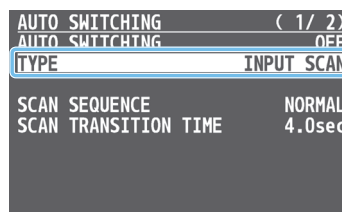

2. Use the [VALUE] knob to select “BPM SYNC,” and press the [VALUE] knob.
3. Use the [VALUE] knob to select a menu item, and press the [VALUE] knob.



Menu item	Explanation
BPM	Specifies the BPM.
MODE	Specifies how the video is switched.
	<b>TRANSITION:</b> The video switches using the currently selected transition effect (mix or wipe).
	<b>CUT:</b> The video switches as a cut.
SPEED	Specifies the video switching speed as a multiple of the specified BPM.
TAP RESET	Specifies how the video switches while you edit the BPM with the [DSK PVW] or [DSK ON] buttons.

4. Use the [VALUE] knob to change the value of the setting.
5. Press the [MENU] button several times to close the menu.

**MEMO**

If the “BPM TAP” function is assigned to the [DSK PVW] or [DSK ON] button, you can set the BPM according to the tempo at which you press the button (p. 41). The [DSK PVW] or [DSK ON] button flashes in sync with the current BPM setting.

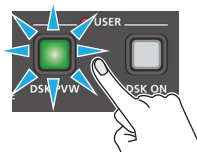

## Loading a Still Image

You can load a still image, and output it in the same way as video (p. 22) or use it as a source for DSK compositing (p. 29). There are two ways to load a still image: you can load from a USB flash drive, or you can capture from input video.

You can save up to four still images in the unit.

\* When still images are saved in the unit, startup takes longer time according to image size and the number of still images saved.

## Loading a Still Image from a USB Flash Drive

Here's how to load a still image from a USB flash drive into the unit.

### NOTE

- Still images cannot be scaled. In advance, you must prepare still images of the resolution that is appropriate for your output format.
- When using a USB flash drive for the first time, you must format it using this unit (p. 39).
- Never turn off the power or remove the USB flash drive while the message "PLEASE WAIT" is shown.
- Depending on the USB flash drive, recognition of the flash drive might take some time.

## Formats supported for loading

<b>Format</b>	Windows Bitmap file (.bmp), 24-bit color, uncompressed PNG file (.png), 24-bit color * Alpha channel is not supported.
<b>Resolution</b>	Maximum 1920 x 1080 pixels
<b>File name</b>	No more than 28 single-byte alphanumeric characters * The extension ".bmp" or ".png" must be added.

## Loading a still image

1. Save the still image in the root directory of the USB flash drive.
2. Connect the USB flash drive containing the still image to the USB MEMORY port.
3. [MENU] button → "STILL IMAGE" → select "LOAD FROM USB MEMORY," and press the [VALUE] knob.



A "\*" symbol is displayed for memory where a still image is already saved.

4. Use the [VALUE] knob to select the loading destination for the still image (STILL 1–4), and press the [VALUE] knob. A list of the still images in the USB flash drive is shown.

5. Use the [VALUE] knob to select the still image file you want to load, and press the [VALUE] knob.

A confirmation message appears.

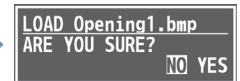
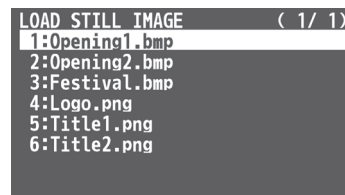

\* If you want to cancel the operation, press the [MENU] button.

6. Use the [VALUE] knob to select "YES," and press the [VALUE] knob.

The still image is loaded into the unit. When the operation is finished, the message "COMPLETE" appears.

\* Large-size still-image files and PNG files might take some time to load.

7. Press the [MENU] button several times to close the menu.

## Capturing a Still Image from Input Video

Here's how to capture a still image from the input video.

### NOTE

Do not turn off the power while the message "PLEASE WAIT" is shown.

1. [MENU] button → "STILL IMAGE" → select "CAPTURE IMAGE," and press the [VALUE] knob.

CAPTURE IMAGE screen appears.

Also, the B/PST cross-point [1]–[4] buttons blink yellow.

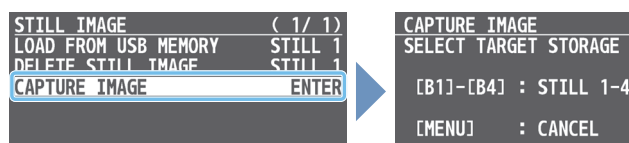

2. Press a B/PST cross-point [1]–[4] button to select a save destination memory (STILL 1–4) for the captured still image.

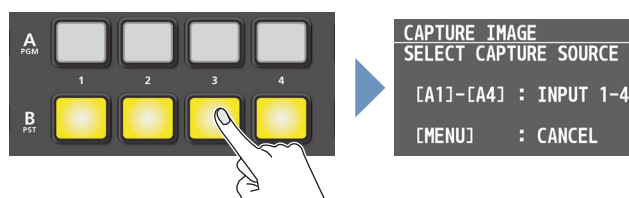

\* If you want to cancel the operation, press the [MENU] button.

3. Press a A/PGM cross-point [1]–[4] button that is blinking red to select the input video from which you want to capture.

The capture is executed. When the operation is finished, the message "COMPLETE" appears.

Blinking red: Video input available

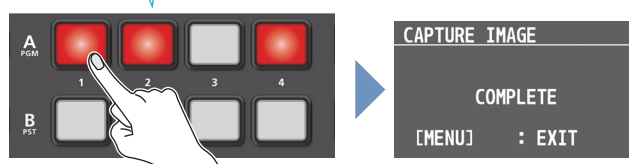

4. Press the [MENU] button several times to close the menu.

### MEMO

- Depending on the format of the input video, completion of still-image capture might take some time.
- If you capture when HDCP (p. 13) is on, the still image that is created is handled in the same way as HDCP-protected video. It cannot be used if HDCP is off.
- You can't save the captured still image to the USB flash drive.

## Deleting a Still Image

Here's how to delete the still image that's saved in the unit.

1. [MENU] button → "STILL IMAGE" → select "DELETE STILL IMAGE," and press the [VALUE] knob.

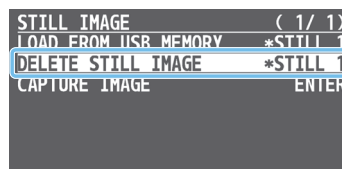

2. Use the [VALUE] knob to select the still image (STILL 1–4) you want to delete, and press the [VALUE] knob.

A confirmation message appears.



\* If you want to cancel the operation, press the [MENU] button.

3. Use the [VALUE] knob to select "YES," and press the [VALUE] knob.

The still image is deleted. When the operation is finished, the message "COMPLETE" appears.

4. Press the [MENU] button several times to close the menu.

## Outputting a Loaded Still Image

You can assign a still image to INPUT 1–4 and output it in the same way as with video, or momentarily stop the final output to output the still image.

### Assigning Still Images to INPUT 1–4

A still image loaded into this unit can be assigned to the video source for INPUT 1–4, and output in the same way as video.

1. Load a still image into this unit as described by the following procedures.
  - ➔ “Loading a Still Image from a USB Flash Drive” (p. 20)
  - ➔ “Capturing a Still Image from Input Video” (p. 21)
2. [MENU] button → “VIDEO INPUT” → select “INPUT 1”–“INPUT 4 (SCALER),” and press the [VALUE] knob.

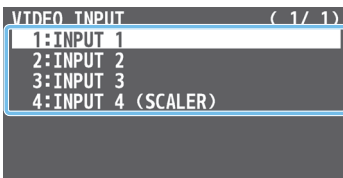

3. Use the [VALUE] knob to select “INPUT ASSIGN,” and press the [VALUE] knob.

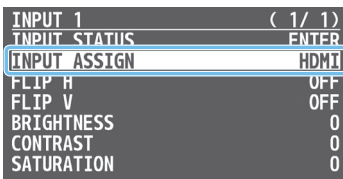

4. Select the still image to assign (STILL 1–4) using the [VALUE] knob.
5. Press the [MENU] button several times to close the menu.
6. Follow the steps in “Switching the Video” (p. 14) to output the still image.

### Inserting a Still Image in the Final Output

You can pause the final output, and output a still image of your choice.

\* The same still image as the final output is also output to the preview.

1. Load a still image into this unit as described by the following procedures.
  - ➔ “Loading a Still Image from a USB Flash Drive” (p. 20)
  - ➔ “Capturing a Still Image from Input Video” (p. 21)
2. Press the [MODE] button several times to select “STILL IMAGE.”

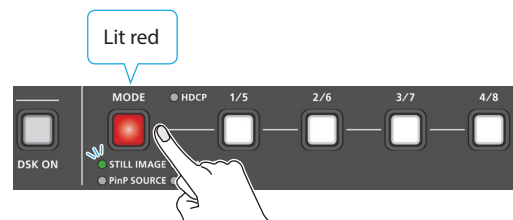

The [1/5]–[4/8] buttons function as still image (STILL 1–4) selection buttons.

3. Press a [1/5]–[4/8] button to select the still image you want to output.

The selected button lights up in red, and the still image is output as a cut.

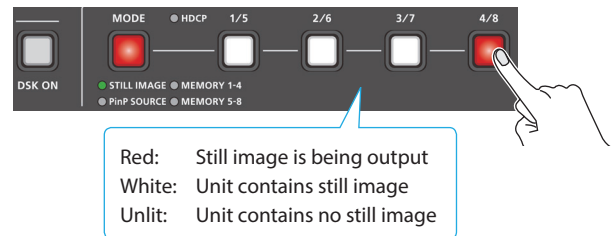

4. To return to normal output, press buttons [1/5]–[4/8] that are lit up red.

The normal output resumes via a cut.

#### MEMO

- When using buttons [1/5]–[4/8] to output a still image, a red indicator is shown in the still image section of the multi-view.



- You can assign functions to the [OUTPUT FADE] knob as well as the [DSK PVW] and [DSK ON] buttons for outputting a still image.
  - ➔ “[OUTPUT FADE] knob functions” (see the memo on p. 23)
  - ➔ “Assigning Different Functions to Control with the [DSK PVW] and [DSK ON] Buttons” (p. 41)

## Fading-In/Out the Final Output Video

Here's how to perform a fade-out from the final output video to a black/white screen, or a fade-in from a black/white screen to the final output video.

A scene that you don't want to output as video can be changed to a black/white screen.

\* The final output video and audio fades in/out together when using the factory default settings.

\* The fade-in/out effect is applied only to the final output.

1. Turn the [OUTPUT FADE] knob all the way clockwise or counterclockwise.



Turning the [OUTPUT FADE] knob clockwise performs a fade-out to white, and turning the knob counterclockwise performs a fadeout to black.

2. To fade-in, return the [OUTPUT FADE] knob to the center.

### MEMO

#### [OUTPUT FADE] knob functions

You can assign a different function to control with the [OUTPUT FADE] knob.

To make this setting, use the [MENU] button → "SYSTEM" → and set OUTPUT FADE ASSIGN "TURN LEFT" or "TURN RIGHT."

Value	Explanation
BLACK	The final output video is faded-in/out to a black screen.
WHITE	The final output video is faded-in/out to a white screen.
AUDIO	Adjusts the output volume.
BLACK&AUDIO	Fades-in/out the final output video and audio simultaneously. The video fades to a black screen.
WHITE&AUDIO	Fades-in/out the final output video and audio simultaneously. The video fades to a white screen.
STILL 1-4 OUTPUT	The specified still image is output as a cut to final/preview output.

## Freezing the Input Video (Freeze)

Here's how to temporarily freeze the input video (freeze function). You can apply transition effects during a video freeze.

### Setting the Operation mode

There are two freeze modes: the "ALL mode" for freezing all input video, and the "SELECT mode" that freezes only the input video you specify. Set the mode that matches your needs.

1. [MENU] button → "FREEZE" → select "TYPE," and press the [VALUE] knob.

FREEZE	( 1 / 1 )
FREEZE	OFF
TYPE	ALL

2. Turn the [VALUE] knob to select "ALL" or "SELECT," and press the [VALUE] knob.

Value	Explanation
ALL	Freezes all video that is being input.
SELECT	Freezes only the specified input video.

If "SELECT" is selected

3. Use the [VALUE] knob to select "INPUT 1"–"INPUT 4," and press the [VALUE] knob.

FREEZE	( 1 / 1 )
FREEZE	OFF
TYPE	SELECT
-INPUT 1	ENABLE
-INPUT 2	ENABLE
-INPUT 3	ENABLE
-INPUT 4	ENABLE

4. Use the [VALUE] knob to select "ENABLE" or "DISABLE."

Value	Explanation
ENABLE	The input video freezes.
DISABLE	The input video does not freeze.

5. Press the [MENU] button several times to close the menu.

## Freezing the Input Video

1. [MENU] button → "FREEZE" → select "FREEZE," and press the [VALUE] knob.

FREEZE	( 1 / 1 )
FREEZE	OFF
TYPE	ALL

2. Use the [VALUE] knob to select "ON."

The freeze function turns on, and the input video freezes.

3. Press the [MENU] button several times to close the menu.

### MEMO

You can assign the freeze function to the [DSK PVW] or [DSK ON] button and turn it on/off (p. 41).

# Video Composition Operations

## Compositing Video with Split

Here's how to composite two videos in dividing the screen into left/right or upper/lower.

### ● Positioning a video

Left or upper: Video on the A/PGM bus

Right or lower: Video on the B/PST bus

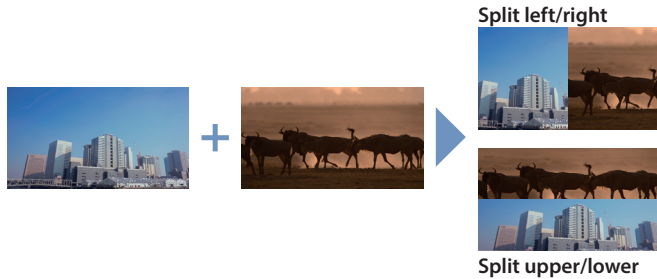

1. Press a A/PGM cross-point [1]–[4] button to select the video you want to display upper or on the left.

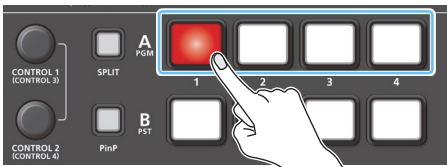

2. Press a B/PST cross-point [1]–[4] button to select the video you want to display lower or on the right.

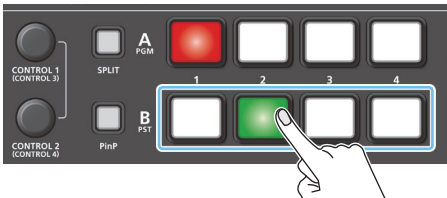

3. Press the [SPLIT] button to turn on split compositing, (lit).

The video you selected in steps 1 and 2 is composited.

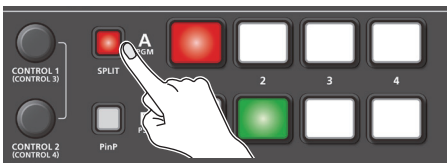

4. Press and turn the [CONTROL 2] knob to select the composition type.

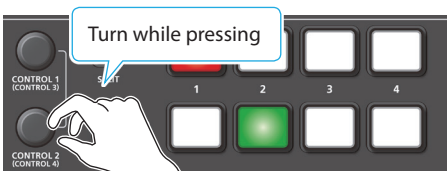

Value	Explanation
SPLIT V	This vertically crops the center section of the video. 
SPLIT H	This horizontally crops the center section of the video. 

5. Use the [CONTROL 1] and [CONTROL 2] knob to adjust the position of the video or boundary.

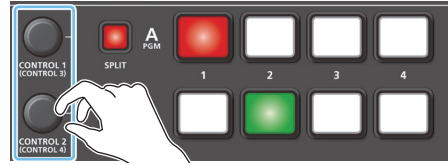

If you turn a knob while pressing it, these knobs function as [CONTROL 3] [CONTROL 4] knobs.

Knob	Explanation
[CONTROL 1]	Adjusts the position of the video that is shown in the left or upper side.
[CONTROL 2]	Adjusts the position of the video that is shown in the right or lower side.
[CONTROL 3]	Adjusts the position of the boundary.
[CONTROL 4]	Selects the split composition types (step 4).

6. To turn off split compositing, press the [SPLIT] button once again.

### MEMO

- **What the [CONTROL 1] and [CONTROL 2] knobs operate**  
When both split and PinP compositing (p. 25) are on, use the [CONTROL 1] and [CONTROL 2] knobs to operate either setting. Set the target of operation from the [MENU] button, "SYSTEM" → "CONTROL KNOB PRIORITY."
- You can change the color and width of the boundary.  
To make this setting, use the [MENU] button → "SPLIT" → "BORDER COLOR" and "BORDER WIDTH."



## Compositing Video with Picture-in-Picture (PinP)

Here's how to composite an inset screen (a small separate screen) onto the background video.



### Setting the Operation Mode

There are two operation modes for PinP compositing, "PVW.PGM mode" and "PVW mode." The timing at which the inset screen is output depends on the mode.

#### PVW.PGM mode (factory settings)

Press the [PinP] button to turn PinP compositing on/off. When PinP compositing is on, the inset screen is sent to final output immediately. The inset screen is displayed on both the preview output and the final output.

#### PVW mode

Turn the inset screen preview output on/off with the [PinP] button. Turning this on displays the inset screen only on the preview output. You can check the composited result before final output. Switching the video with the [AUTO] and [CUT] buttons or the video fader turns PinP compositing on, and the composited result is sent to final output.

1. [MENU] button → "PinP" → select "PinP TARGET," and press the [VALUE] knob.

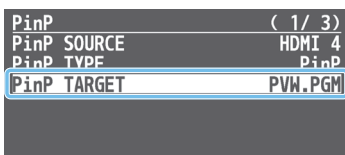

2. Turn the [VALUE] knob to select "PVW.PGM" or "PGM."
3. Press the [MENU] button several times to close the menu.

### Sending the Inset Screen to Final Output Immediately

Here are the steps when selecting "PVW.PGM mode" in the operation mode settings.

For more details on the operation modes, see "Setting the Operation Mode" on this page.

1. Press the [MODE] button several times to select "PinP SOURCE."

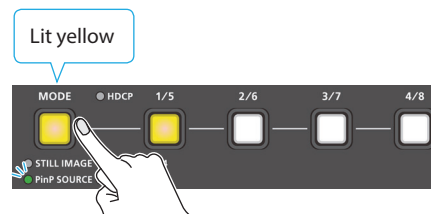

The [1/5]–[4/8] buttons function as the video select button (HDMI 1–4) for the inset screen.

2. Press a [1/5]–[4/8] button to select the video you want to make the inset screen.

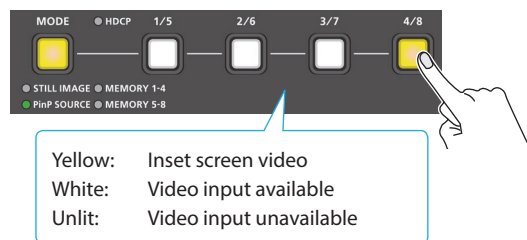

3. Press the [PinP] button to turn on PinP compositing (lit).

The inset screen is displayed on the preview output/final output.



4. Use the [CONTROL 1] [CONTROL 2] knobs to adjust the inset screen.

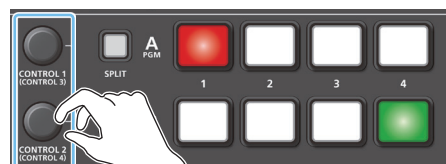

If you turn a knob while pressing it, these knobs function as [CONTROL 3] [CONTROL 4] knobs.

Knob	Explanation
[CONTROL 1]	Adjusts the horizontal position of the inset screen.
[CONTROL 2]	Adjusts the vertical position of the inset screen.
[CONTROL 3]	Adjusts the size (zoom) of the inset screen.
[CONTROL 4]	Adjusts the zoom of the video shown in the inset screen.

5. To turn off PinP compositing, press the [PinP] button once again.

## MEMO

- Set the fade-in/out time for the inset screen from the [MENU] button → “TRANSITION” → “PinP TIME.”
- **What the [CONTROL 1] and [CONTROL 2] knobs operate**  
When both split (p. 24) and PinP compositing are on, use the [CONTROL 1] and [CONTROL 2] knobs to operate either setting. Set the target of operation from the [MENU] button, “SYSTEM” → “CONTROL KNOB PRIORITY.”
- The still images loaded into this unit (p. 20) can be used as source images for the inset screen. Use the [MENU] button → “PinP” → and set “PinP SOURCE” to “STILL 1–4.”

## Checking the Composited Result for Final Output

Here are the steps when selecting “PVW mode” in the operation mode settings.

For more details on the operation modes, see “Setting the Operation Mode” (p. 25).

### 1. Preview output the background video.

At the PVW section of the multi-view, check the video to be made the background.

### 2. Press the [MODE] button several times to select “PinP SOURCE.”

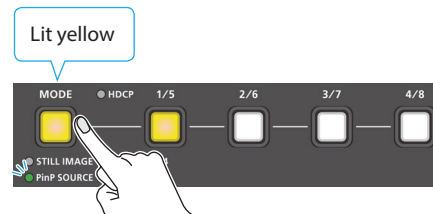

The [1/5]–[4/8] buttons function as the video select button (HDMI 1–4) for the inset screen.

### 3. Press a [1/5]–[4/8] button to select the video you want to make the inset screen.

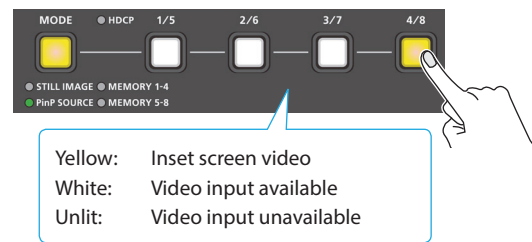

### 4. Press the [PinP] button to turn on the inset screen preview output.

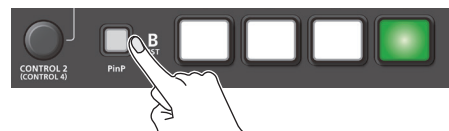

The inset screen appears in the PVW section of the multi-view, allowing you to check the inset screen’s location and size. At this stage, the final output has not yet been changed.

### 5. Use the [CONTROL 1] [CONTROL 2] knobs to adjust the inset screen.

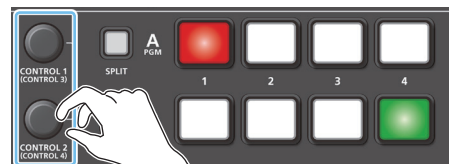

If you turn a knob while pressing it, these knobs function as [CONTROL 3] [CONTROL 4] knobs.

Knob	Explanation
[CONTROL 1]	Adjusts the horizontal position of the inset screen.
[CONTROL 2]	Adjusts the vertical position of the inset screen.
[CONTROL 3]	Adjusts the size (zoom) of the inset screen.
[CONTROL 4]	Adjusts the zoom of the video shown in the inset screen.

6. Press the [AUTO] or [CUT] button to switch the video.

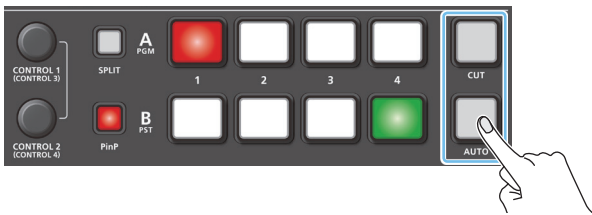

The [PinP] button lights up, then PinP compositing turns on. The inset screen is composited onto the background video and the result is sent to final output.

\* The video fader can be similarly used.

7. To turn off PinP compositing, press the [AUTO] or [CUT] button once again.

The [PinP] button goes dark.

8. To turn off the inset screen preview output, press the [PinP] button once again.

**MEMO**

- Long-press the [PinP] button to switch between displaying or hiding only the inset screen used for final output.

The fade-in/out time settings for the inset screen are applied (made from the [MENU] button → "TRANSITION" → "PinP TIME").

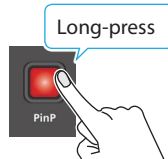

- **What the [CONTROL 1] and [CONTROL 2] knobs operate**  
When both split (p. 24) and PinP compositing are on, use the [CONTROL 1] and [CONTROL 2] knobs to operate either setting. Set the target of operation from the [MENU] button, "SYSTEM" → "CONTROL KNOB PRIORITY."
- The still images loaded into this unit (p. 20) can be used as source images for the inset screen.  
Use the [MENU] button → "PinP" → and set "PinP SOURCE" to "STILL 1-4."

Making Detailed Settings for the Inset Screen

Detailed settings for size, shape, and border width etc. can be made for the inset screens.

1. [MENU] button → select "PinP," and press the [VALUE] knob.

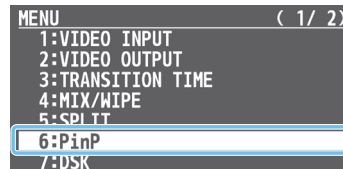

2. Use the [VALUE] knob to select a menu item, and press the [VALUE] knob.

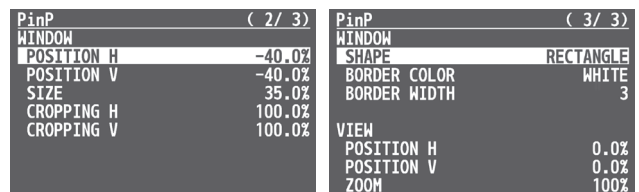

Menu item	Explanation
<b>WINDOW</b>	Adjusts the inset screen.
POSITION H	Adjusts the horizontal position.
POSITION V	Adjusts the vertical position.
SIZE	Adjusts the size (zoom).
CROPPING H	Adjusts the horizontal size.
CROPPING V	Adjusts the vertical size.
SHAPE	Specifies the shape (rectangle, circle, diamond).
BORDER COLOR	Specifies the color of the border.
BORDER WIDTH	Adjusts the width of the border.
<b>VIEW</b>	Adjusts the video that is shown in the inset screen.
POSITION H	Adjusts the horizontal position.
POSITION V	Adjusts the vertical position.
ZOOM	Adjusts the zoom.

3. Use the [VALUE] knob to change the value.

4. Press the [MENU] button several times to close the menu.

## Key Compositing the Inset Screen

This process makes part of the inset screen transparent, and composites the image with the background video.

You can use luminance key with either a black or a white background, or a chroma key with either a blue or green background.

### Luminance key

You can cut out a logo or image by turning its black or white portion transparent, and then superimpose it on the background video.

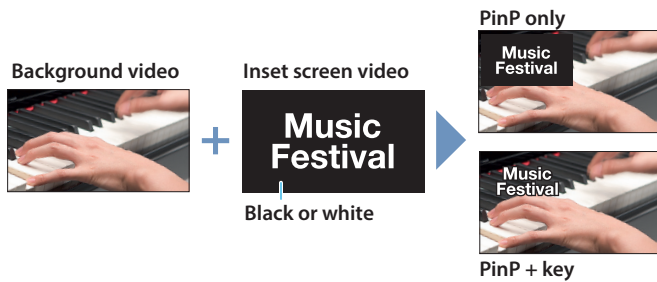

### Chroma key

You can cut out a video by turning its blue or green portion transparent, and then superimpose it on the background video.

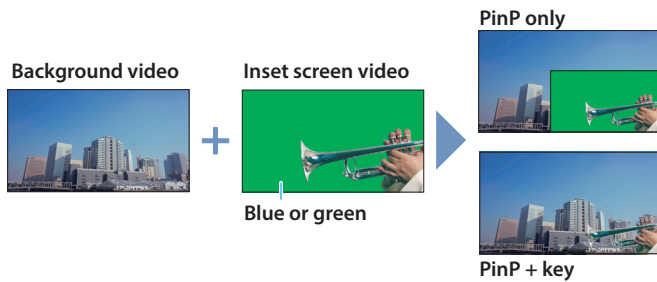

1. [MENU] button → “PinP” → select “PinP TYPE,” and press the [VALUE] knob.

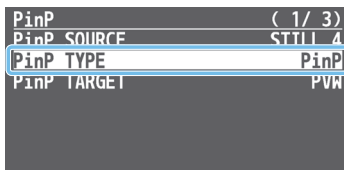

2. Use the [VALUE] knob to select the type of PinP compositing, and press the [VALUE] knob.

Value	Explanation
LUMINANCE-WHITE KEY	A combination of PinP and luminance key (white). Makes the white portions of the inset screen transparent, and composites the image with the background.
LUMINANCE-BLACK KEY	A combination of PinP and luminance key (black). Makes the black portions of the inset screen transparent, and composites the image with the background.
CHROMA KEY	A combination of PinP and chroma key. Makes the blue or green portions of the inset screen transparent, and composites the image with the background.

3. Select the menu item and adjust the intensity of the effect.

\* For details on the menu items, refer to “6: PinP” (p. 47).

4. Press the [MENU] button several times to close the menu.

## Compositing Video with Downstream Keyer (DSK)

This process performs key compositing on text or video downstream (DSK compositing) of a video that was already composited upstream. You can switch between background video while still displaying the text or video.

With DSK composition, you can use luminance key with either a black or a white background, or a chroma key with either a blue or green background.

### Compositing a Logo or Image (Luminance Key)

Here's how you can cut out a logo or image by turning its black or white portion transparent, and then superimpose it on the background video.



### Adjusting the depth of compositing

#### 1. Preview output the background video.

At the PVW section of the multi-view, check the video to be made the background.

#### 2. Press the [DSK PVW] button to turn on the preview output (lit).

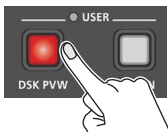

A preview of the composition results is displayed in the PVW section of the multi-view.

At this stage, the final output has not yet been changed.

#### 3. [MENU] button → "DSK" → select the menu item shown below, and press the [VALUE] knob.

DSK	( 1 / 4 )
DSK PVW	ON
DSK	OFF
DSK SOURCE	HDMI 4
DSK TYPE	LUMINANCE-WHITE
DSK LEVEL	64
DSK GAIN	0
MIX LEVEL	255

##### ● DSK SOURCE

Select the source of the logo or image that you want to superimpose.

Value	Explanation
HDMI 1-4	Input video from the INPUT 1-4 connectors
STILL 1-4	A still image loaded into the unit (p. 20)

##### ● DSK TYPE

Choose "LUMINANCE-WHITE" or "LUMINANCE-BLACK."

Value	Explanation
LUMINANCE-WHITE	Makes white portions transparent according to brightness.
LUMINANCE-BLACK	Makes black portions transparent according to brightness.

##### ● DSK LEVEL

Adjusts the degree of extraction for the key.

##### ● DSK GAIN

Adjusts the degree of edge blur for the key.

##### ● MIX LEVEL

Adjusts the key's overall density (output level).

#### 4. Use the [VALUE] knob to change the value.

Configure the settings for each menu item while checking the composited result.

#### 5. Press the [MENU] button several times to close the menu.

### Compositing using DSK

#### 1. Press the [DSK ON] button to turn on DSK compositing (lit).

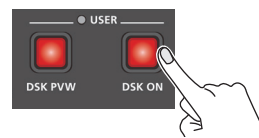

The composition results is sent to final output.

#### 2. To turn off DSK compositing, press the [DSK ON] button once again.

### Modifying the logo or image

You can fill-in the superimposed logo or image, or add an edge to it. Make these settings.

Use the [MENU] button → "DSK" to make the settings for the following menu items.

Menu item	Explanation
FILL TYPE	If this is "MATTE," the superimposed logo or video is filled-in with the specified color. The fill-in color is specified by "MATTE COLOR."
MATTE COLOR	
EDGE TYPE	Specifies the type of edge.
EDGE COLOR	Specifies the color of the edge.
EDGE WIDTH	Specifies the width of the edge.

#### MEMO

- Set the fade-in/out time for logos and images from the [MENU] button → "TRANSITION" → "DSK TIME."
- You can assign different functions to control with the [DSK PVW] and [DSK ON] buttons (p. 41). If the USER indicator is not lit, the buttons function as [DSK PVW] and [DSK ON] buttons.

## Compositing a Subject and Background (Chroma Key)

Here's how you can cut out a video by turning its blue or green portion transparent, and then superimpose it on the background video. This lets you composite a subject that's photographed against a blue background or green background.

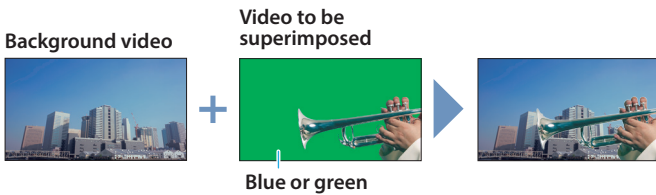

### Adjusting the depth of compositing

**1. Preview output the background video.**

At the PVW section of the multi-view, check the video to be made the background.

**2. Press the [DSK PVW] button to turn on the preview output (lit).**

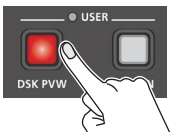

A preview of the composition results is displayed in the PVW section of the multi-view.  
At this stage, the final output has not yet been changed.

**3. [MENU] button → "DSK" → select the menu item shown below, and press the [VALUE] knob.**

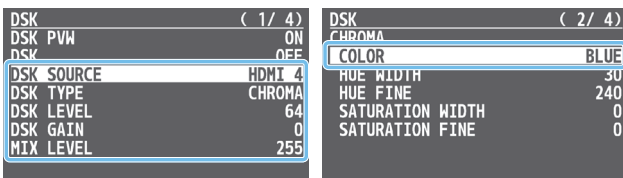

**DSK SOURCE**

Select the video that you want to superimpose.

Value	Explanation
HDMI 1-4	Input video from the INPUT 1-4 connectors
STILL 1-4	A still image loaded into the unit (p. 20)

**DSK TYPE**

Set to "CHROMA."

**DSK LEVEL**

Adjusts the degree of extraction for the key.

**DSK GAIN**

Adjusts the degree of edge blur for the key.

**MIX LEVEL**

Adjusts the key's overall density (output level).

**COLOR**

Specify either "GREEN" or "BLUE" as the key color for chroma key (the color to be removed).

**4. Use the [VALUE] knob to change the value.**

Configure the settings for each menu item while checking the composited result.

**5. Press the [MENU] button several times to close the menu.**

### Compositing using DSK

**1. Press the [DSK ON] button to turn on DSK compositing (lit).**

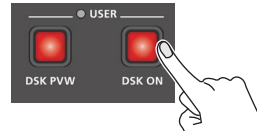

The composition results is sent to final output.

**2. To turn off DSK compositing, press the [DSK ON] button once again.**

### Finely adjusting the key color (removed color)

You can make fine adjustments to the key color (the color that is removed).

Use the [MENU] button → "DSK" to make the settings for the following menu items.

Menu item	Explanation
HUE WIDTH	Adjusts the hue width.
HUE FINE	Adjusts the center position of the hue.
SATURATION WIDTH	Adjusts the saturation width.
SATURATION FINE	Adjusts the center position of saturation.

### Modifying the superimposed video

You can fill-in the superimposed video, or add an edge to it.

Use the [MENU] button → "DSK" to make the settings for the following menu items.

Menu item	Explanation
FILL TYPE	If this is set to "MATTE," the superimposed video is filled-in with the specified color.
MATTE COLOR	The fill-in color is specified by "MATTE COLOR."
EDGE TYPE	Specifies the type of edge.
EDGE COLOR	Specifies the color of the edge.
EDGE WIDTH	Specifies the width of the edge.

**MEMO**

- Set the fade-in/out time for the video to superimpose from the [MENU] button → "TRANSITION" → "DSK TIME"
- You can assign different functions to control with the [DSK PVW] and [DSK ON] buttons (p. 41). If the USER indicator is not lit, the buttons function as [DSK PVW] and [DSK ON] buttons.

## To specify a desired color as the key color (sampling marker)

You can select a key color besides green or blue to use for chroma key compositing.

Sample (detect) the color in the video that you wish to make transparent, and set it as the key color (this is called the sampling marker function).

1. [MENU] button → "DSK" → select "SAMPLING MARKER," and press the [VALUE] knob.

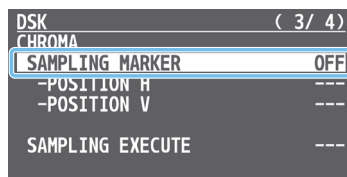

2. Use the [VALUE] knob to select "ON," and press the [VALUE] knob.

The sampling marker (  ) is shown on the preview output video.

3. Use the [VALUE] knob to select "POSITION H" or "POSITION V," and press the [VALUE] knob.

4. Use the [VALUE] knob to adjust the position of the sampling marker

Menu item	Explanation
POSITION H	Adjusts the horizontal position.
POSITION V	Adjusts the vertical position.

5. Use the [VALUE] knob to select "SAMPLING EXECUTE," and press the [VALUE] knob.

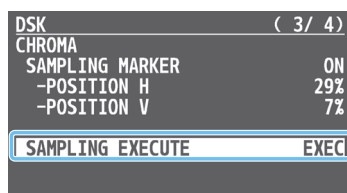

A confirmation message appears.

\* If you want to cancel the operation, press the [MENU] button.

6. Use the [VALUE] knob to select "YES," and press the [VALUE] knob.

The key color is sampled.

The "HUE WIDTH," "HUE FINE," "SATURATION WIDTH," and "SATURATION FINE" settings are adjusted automatically.

7. Press the [MENU] button several times to close the menu.

# Audio Operations

## Adjusting the Input Gain (Sensitivity)

Here's how to adjust the input gain so that the audio is at the appropriate level.

### AUDIO IN 1 and 2

Here we explain using the AUDIO IN 1 audio as an example.

1. Move the [AUDIO IN 1] knob to a position near the indicator (0 dB).

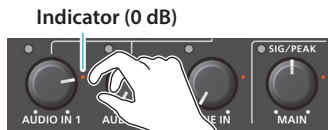

2. Move the [MAIN] knob to a position near the indicator (0 dB).



3. Turn the [GAIN 1] knob fully counter-clockwise, minimizing (0 dB) the input gain.



4. While producing the sound that will actually be input, slowly turn the [GAIN 1] knob clockwise to adjust the input gain.

Raise the input gain as high as possible without allowing the SIG/PEAK indicator of AUDIO IN 1 to light red when the loudest sound level occurs.



### MEMO

#### Stereo link function

You can link AUDIO IN 1 and 2 to operate them as a stereo channel.

Long-press the [SETUP] button to turn the stereo link function on/off.



- \* When stereo link is turned on, the settings of AUDIO IN 1 are applied to AUDIO IN 2.
- \* When stereo link is on, the [GAIN 2] and [AUDIO IN 2] knobs are disabled.
- \* When phantom power is on and you switch the stereo link setting on/off, phantom power automatically turns off.

#### Adjusting the mic position (pan)

The left/right positioning of the sound is called "pan." If you're using two mics to stream a performance, panning the two mics to left and right will give the sound a more spacious feel.

To make adjustments, use the [SETUP] button → "AUDIO IN 1" or "AUDIO IN 2" → "PAN."

#### SIG/PEAK indicator

Indicator	Explanation
Red	Lit when excessive input occurs (0 dB or higher).
Yellow	Lit when audio is input (-20~ -1 dB).
Green	Lit when audio is input (-50~ -21 dB).

### MIC/AUX IN

1. Move the [MAIN] knob to a position near the indicator (0 dB).



2. [SETUP] button → select "MIC/AUX IN," and press the [VALUE] knob.

3. Use the [MIC/AUX IN] knob to set "INPUT LEVEL" to "0.0dB."

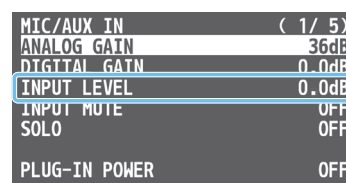

4. Use the [VALUE] knob to select "ANALOG GAIN," and press the [VALUE] knob.



5. Turn the [VALUE] knob fully counter-clockwise, minimizing (0 dB) the input gain.

6. While producing the sound that will actually be input, slowly turn the [GAIN 1] knob clockwise to adjust the input gain.

Raise the input gain as high as possible without allowing the level meter to light red when the loudest sound level occurs.

- \* The level meter is displayed in the multi-view.

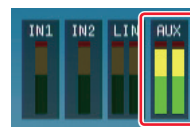

7. Press the [MENU] button several times to close the menu.



## Adjusting the Volume Balance

Here's how to adjust the volume balance of each input and the overall volume.

### 1. Move the [MAIN] knob to a position near the indicator (0 dB).



### 2. While monitoring the audio via speakers or headphones, adjust the volume balance for the respective inputs.

Raise the volume level of audio you want to make more prominent, for example, an emcee microphone, and lower the volume level for other audio.

When no audio is input, and for audio that is unused, lower the volume level to minimum (-INF dB).

#### AUDIO IN 1-2, LINE IN, MIC/AUX IN

#### 1 Use the [AUDIO IN 1], [AUDIO IN 2], [LINE IN], and [MIC/AUX IN] knobs to adjust the volume.



#### INPUT 1-4

#### 1 Press the [SETUP] button → "INPUT 1"-"INPUT 4" → select "INPUT LEVEL," and press the [VALUE] knob.

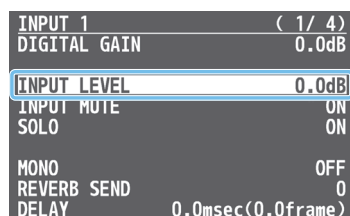

#### 2 Use the [VALUE] knob to adjust the volume.

#### 3 Press the [MENU] button several times to close the menu.

### 3. Use the [MAIN] knob to adjust the volume of the output.



When this is adjusted appropriately, the SIG/PEAK indicator will light yellow.

### Level meter indication

The audio level meter is shown in each section of the multi-view. The level meter illumination lets you check whether the volume is adjusted appropriately.

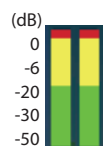

Indicator	Status
Red	Lights up at 0 dB or higher. It indicates an excessive volume level.
Yellow	Lights up at -20 to -1 dB. It indicates an appropriate volume level.
Green	Lights up at -50 to -21 dB. It indicates a too-low volume level.

#### MEMO

- With the factory settings, if you use the [OUTPUT FADE] knob to fade-in/out the final output video (p. 23), the output audio also fades-in/out simultaneously. You can change the function that's assigned to the [OUTPUT FADE] knob so that it adjusts only the output volume. Use the [MENU] button → "SYSTEM" → and set OUTPUT FADE ASSIGN "TURN LEFT" or "TURN RIGHT" to "AUDIO."
- You can output a test tone that is useful when making volume adjustments. Use the [MENU] button → "SYSTEM" → "TEST TONE" to select the type of test tone that will be output.

## Applying Effects to Input Audio

You can apply effects to the input audio to adjust the character of the sound. The following table shows the effects that are available.

Input audio	High-pass filter	Noise gate	De-esser	Compressor	Equalizer	Reverb
INPUT 1-4	✓	✓	—	✓	✓	✓
AUDIO IN 1, 2	✓	✓	✓	✓	✓	✓
LINE IN	✓	✓	—	✓	✓	✓
MIC/AUX IN	✓	✓	✓	✓	✓	✓

1. [SETUP] button → select “INPUT 1”–“MIC/AUX IN,” and press the [VALUE] knob.

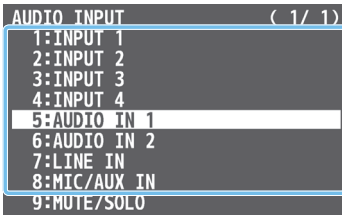

2. Using the [VALUE] knob, select the menu item of the effect you want to use, and press the [VALUE] knob.
  - \* For details on the menu items, refer to “8: AUDIO INPUT” (p. 50).
3. Use the [VALUE] knob to change the value of the setting.
4. Press the [MENU] button several times to close the menu.

## Using an Effect Preset

This unit is equipped with effects that are adjusted for specific environments. These are called “effect presets.”

Simply by selecting an effect preset, you can easily apply an effect that’s appropriate for your situation.

### MEMO

- Effect presets are combinations of effects besides reverb. To fine-tune the preset settings, edit the settings for each effect. For details on the effects, refer to “8: AUDIO INPUT” (p. 50).
- You cannot overwrite the effect presets. Use the preset memories to save the settings for presets you’ve edited (p. 38).
- When you load an effect preset, each preset setting (except for reverb) is restored to its default setting (factory defaults).

### ● High-pass filter

Cuts off unneeded low-band audio. The cutoff frequency is 80 Hz.

### ● Noise gate

Eliminates audio that is lower than the specified threshold level. This is effective when the noise that you want to remove is separate from the audio that you want to keep, and can be used to remove hiss or other noise that is heard during periods of silence.

### ● De-esser

Reduces sibilant noise (the sounds you hear when pronouncing “s” words and other hissing sounds).

### ● Compressor

Audio that exceeds the specified threshold level is compressed. This reduces the difference between the maximum volume and minimum volume, making the audio more comfortable for listening.

### ● Equalizer

This is a three-band equalizer. It lets you adjust the volume by boosting or cutting three frequency regions.

### ● Reverb

Adds reverberation to the sound.

1. [SETUP] button → select “INPUT 1”–“MIC/AUX IN,” and press the [VALUE] knob.
2. Use the [VALUE] knob to select “EFFECT PRESET,” and press the [VALUE] knob.

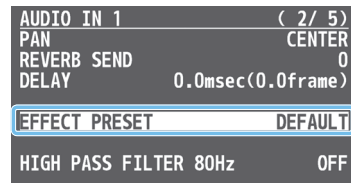

3. Use the [VALUE] knob to select an effect preset, and press the [VALUE] knob.

Value	Explanation
DEFAULT	For line input (default setting)
MEETING	For meetings
INTERVIEW	For interviews
AMBIENT MIC	For capturing ambient sound

A confirmation message appears.



\* If you want to cancel the operation, press the [MENU] button.

4. Use the [VALUE] knob to select “OK,” and press the [VALUE] knob.

The effect preset is loaded. When the operation is finished, the message “COMPLETE” appears.

5. Press the [MENU] button several times to close the menu.

## Applying Reverb

This adds reverberation to the sound.

### Adjusting how much reverb to send

1. [SETUP] button → select “INPUT 1”–“MIC/AUX IN,” and press the [VALUE] knob.
2. Use the [VALUE] knob to select “REVERB SEND,” and press the [VALUE] knob.

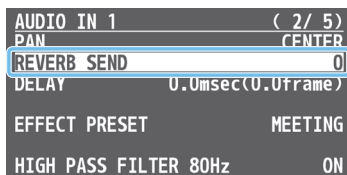

3. Use the [VALUE] knob to adjust the amount of sound that is sent to reverb (reverb depth).
4. Press the [MENU] button several times to close the menu.

### Adjusting how much reverb is returned

1. [MENU] button → “AUDIO OUTPUT” → select “REVERB” and press the [VALUE] knob.

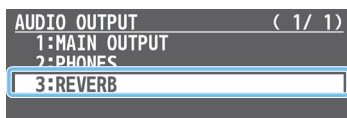

2. Use the [VALUE] knob to select “REVERB,” and press the [VALUE] knob.



3. Use the [VALUE] knob to select “ON,” and press the [VALUE] knob.

Reverb turns on.

4. Use the [VALUE] knob to select “LEVEL,” “TYPE,” or “SIZE,” and press the [VALUE] knob.

Menu item	Explanation
LEVEL	Specifies the amount of sound that is returned from the reverb (return level). This adjusts the depth of the overall reverb.
TYPE	Specifies the reverb type. <b>ROOM:</b> Produces the natural-sounding reverberation of a room. <b>HALL:</b> Produces the reverberation that is typical of a performance in a concert hall.
SIZE	Specifies the size of the room. The larger the value, the longer the reverb time.

5. Use the [VALUE] knob to change the value of the setting.
6. Press the [MENU] button several times to close the menu.

### MEMO

You can assign the function to the [DSK PVW] or [DSK ON] button and turn reverb on/off (p. 41).

## Applying Effects to Output Audio

Here’s how to modify the tonal character by applying effects to the audio output. You can use limiter, compressor, and equalizer.

1. [MENU] button → “AUDIO OUTPUT” → select “MAIN OUTPUT” and press the [VALUE] knob.

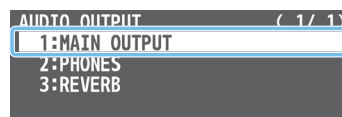

2. Using the [VALUE] knob, select the menu item of the effect you want to use, and press the [VALUE] knob.

\* For details on the menu items, refer to “9: AUDIO OUTPUT” (p. 54).

3. Use the [VALUE] knob to change the value of the setting.
4. Press the [MENU] button several times to close the menu.

### ● Limiter

Limits the output volume so that it does not exceed the specified threshold level.

\* Distortion will occur if audio that exceeds the allowable range of the limiter is input.

### ● Compressor

Audio that exceeds the specified threshold level is compressed. This reduces the difference between the maximum volume and minimum volume, making the audio more comfortable for listening.

### ● Equalizer

This is a three-band equalizer. It lets you adjust the volume by boosting or cutting three frequency regions.

## Interlinking Audio Output to Video Switching (Audio Follow)

Here's how the audio output can be automatically switched in tandem with video switching (the audio follow function).

1. [MENU] button → select "AUDIO FOLLOW," and press the [VALUE] knob.
2. Use the [VALUE] knob to select the input video (INPUT 1–4) that you want to use with Audio Follow, and press the [VALUE] knob.

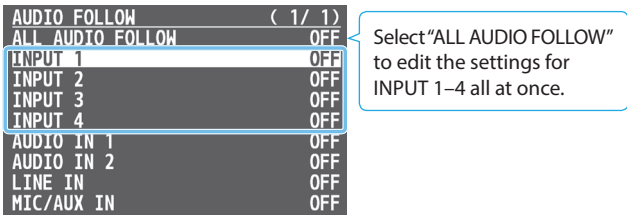

3. Use the [VALUE] knob to select "ON."

Value	Explanation
ON	The audio is output only when the video is selected. The audio is automatically muted if another video is selected.
OFF	The audio is always output regardless of the video selection.

4. Press the [MENU] button several times to close the menu.

## Adding an Object for Audio Follow

Here's how an audio input source other than INPUT 1–4 can be specified as an object for the audio follow function.

1. [MENU] button → "AUDIO FOLLOW" → and select the audio input that will be the object of Audio Follow.

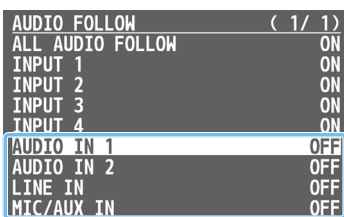

2. Use the [VALUE] knob to select one of "INPUT 1"–"INPUT 4."

Value	Explanation
INPUT 1–4	For each audio source, these settings specify the input video (INPUT 1–4) that will use the audio follow function. Audio is output only when the specified input video is selected.
OFF	The audio is always output regardless of the video selection.

3. Press the [MENU] button several times to close the menu.

### MEMO

The level meter shown of the multi-view indicates the audio follow setting. The "A.F." symbol is shown to indicate audio for which audio follow is on.



## Checking a Specific Audio Input (Solo)

Here's how you can temporarily monitor a specific audio input via the headphones (solo function).

\* The solo function applies to the headphone output. It does not affect output other than the headphones.

1. [SETUP] button → select "MUTE/SOLO," and press the [VALUE] knob.
2. Use the [VALUE] knob to select the audio that you want to monitor, and press the [VALUE] knob.

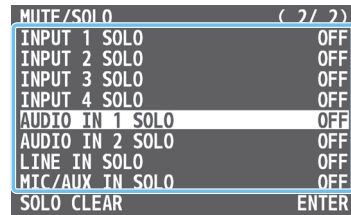

3. Use the [VALUE] knob to select "ON."

In the headphones, you hear only the audio for which this is on.

\* Select "SOLO CLEAR" and press the [VALUE] knob to turn all solo settings off at once.

4. Press the [MENU] button several times to close the menu.

### MEMO

You can turn on the solo function for the HDMI audio while holding down the cross-point button.

Use the [MENU] button → "AUDIO OUTPUT" → "PHONES" → and set "HDMI SOLO" to "USE CROSS-POINT SW."

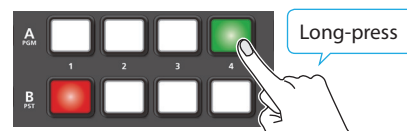

You'll be able to monitor the audio of the final output video or the preview output video while the button is pressed.

## Silencing Only Specific Audio (Mute)

Here's how you can temporarily mute specific audio (the mute function).

### Muting Input Audio

1. [SETUP] button → select "MUTE/SOLO," and press the [VALUE] knob.
2. Use the [VALUE] knob to select the audio that you want to mute, and press the [VALUE] knob.

MUTE/SOLO ( 1 / 2 )	
INPUT 1 MUTE	OFF
INPUT 2 MUTE	OFF
INPUT 3 MUTE	OFF
INPUT 4 MUTE	OFF
AUDIO IN 1 MUTE	OFF
AUDIO IN 2 MUTE	OFF
LINE IN MUTE	OFF
MIC/AUX IN MUTE	OFF

3. Use the [VALUE] knob to select "ON."
4. Press the [MENU] button several times to close the menu.

### Muting Output Audio

1. [MENU] button → "AUDIO OUTPUT" → select "MAIN OUTPUT," and press the [VALUE] knob.
2. Use the [VALUE] knob to select "OUTPUT MUTE," and press the [VALUE] knob.

MAIN OUTPUT ( 1 / 3 )	
OUTPUT LEVEL	0.0dB
OUTPUT MUTE	OFF
LIMITER	OFF
-THRESHOLD	-6dB
-MAKEUP GAIN	0dB
-SOFT CLIP	OFF

3. Use the [VALUE] knob to select "ON."
4. Press the [MENU] button several times to close the menu.

#### MEMO

- You can assign the mute function to the [DSK PVW] or [DSK ON] button and turn it on/off (p. 41).
- The level meter shown of the multi-view indicates the mute setting. The "MT" symbol is shown to indicate audio for which muting is on.



## Correcting a Time Difference Between Video and Audio (Delay)

If there is a timing discrepancy between the video and audio, you can correct the output timing by delaying the audio output.

1. [SETUP] button → select "INPUT 1"-"MIC/AUX IN," and press the [VALUE] knob.
2. Use the [VALUE] knob to select "DELAY," and press the [VALUE] knob.

INPUT 1 ( 1 / 4 )	
DIGITAL GAIN	0.0dB
INPUT LEVEL	0.0dB
INPUT MUTE	OFF
SOLO	OFF
MONO	OFF
REVERB SEND	0
DELAY	0.0msec(0.0frame)

3. Use the [VALUE] knob to adjust the delay time of the input audio.
4. Press the [MENU] button several times to close the menu.

# Other Features

## Saving/Recalling Settings (Preset Memory)

You can save the current settings, including the video/audio settings and the state of the operating panel, in preset memory and recall those settings for use when necessary. This unit is provided with eight memories.

### About the Last Memory function

This unit has a built-in Last Memory feature. Last Memory is a feature that saves the state of the unit that is in effect immediately before power-down, and automatically restores the state at the next startup. The Last Memory feature is enabled by default.

If you want the unit to recall a preset memory when it starts up, press the [MENU] button → "PRESET MEMORY" → "START UP" to specify the preset memory number.

### Saving to a Preset Memory

1. Press the [MODE] button several times to select "MEMORY 1-4" or "MEMORY 5-8."

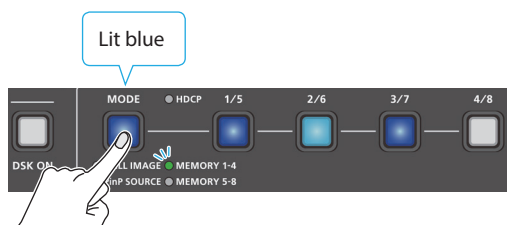

The [1/5]-[4/8] buttons function as memory selection buttons.

MEMORY 1-4	Preset memory selection buttons 1-4
MEMORY 5-8	Preset memory selection buttons 5-8

2. Long-press one of the [1/5]-[4/8] buttons to select the preset memory number where the settings are to be saved.

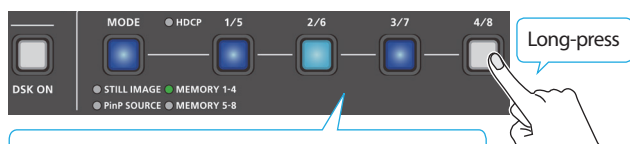

- Blue: Memories in which settings are saved
- Light blue: Currently selected memory
- Unlit: Memories with no settings

All of the [1/5]-[4/8] buttons are briefly illuminated in light blue, and the current settings are saved in the selected preset memory.

#### MEMO

- You can prohibit settings from being saved or initialized (p. 39) to protect the preset memories. Use the [MENU] button → "PRESET MEMORY" → and set "MEMORY PROTECT" to "ON."
- The state of the [OUTPUT FADE] knob and the settings shown below are not saved to preset memories.

AUDIO OUTPUT	PHONES	OUTPUT LEVEL
	AUDIO IN 1, 2	SETUP (LINK) SW
		PHANTOM +48V
	MIC/AUX IN	PLUG-IN POWER
PRESET MEMORY		
STILL IMAGE	All menu items	
SYSTEM		

### Recalling a Preset Memory

1. Press the [MODE] button several times to select "MEMORY 1-4" or "MEMORY 5-8."

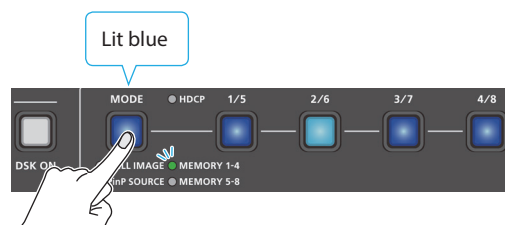

2. Press one of the [1/5]-[4/8] buttons to select the preset memory number to recall.

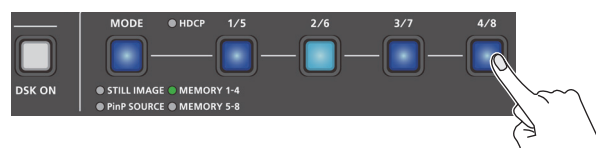

The settings are recalled.

#### MEMO

- About the knob setting value**  
With the factory default settings, the preset memory values are not applied to the knobs when recalling a preset memory. Instead, the current knob settings are retained. If you want the preset memory values to be applied, use the [MENU] button → "PRESET MEMORY" → and set "PRIORITY" to "MEMORY."
- You can choose not to recall a certain setting when recalling a preset memory. For each item selected using the [MENU] button → "PRESET MEMORY" → "LOAD PARAMETER," you can set whether to recall that setting.
- You can set the fade-in time for the inset screen when recalling a preset memory that includes a PinP composite. To make this setting, use the [MENU] button → "PRESET MEMORY" → "PinP FADE TIME."

## Initializing a Preset Memory

Here's how you can initialize the settings of a specific preset memory to the factory-set condition.

1. [MENU] button → "PRESET MEMORY" → select "INITIALIZE," and press the [VALUE] knob.

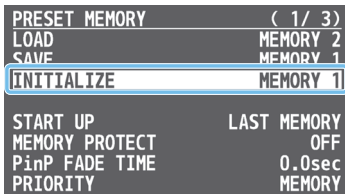

2. Use the [VALUE] knob to select the preset memory (MEMORY 1–8) that you want to initialize, and press the [VALUE] knob.

A confirmation message appears.



\* If you want to cancel the operation, press the [MENU] button.

3. Use the [VALUE] knob to select "YES," and press the [VALUE] knob.

The preset memory is initialized. When the operation is finished, the message "COMPLETE" appears.

4. Press the [MENU] button several times to close the menu.

## Formatting a USB Flash Drive

The first time that you use a USB flash drive, you must use this unit to format it.

### NOTE

- A USB flash drive that was not formatted by this unit will not be recognized.
- Never turn off the power or remove the USB flash drive while the message "PLEASE WAIT" is shown.
- When you format a USB flash drive, all data on that USB flash drive is erased. If the drive contains important data, back it up to your computer before you format the drive.

1. Connect the USB flash drive to the USB MEMORY port.



\* Ensure that the USB flash drive is oriented correctly, and insert it all the way into the port. Do not use excessive force.

2. [MENU] button → "USB MEMORY" → select "FORMAT," and press the [VALUE] knob.

A confirmation message appears.

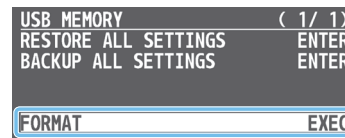

\* If you want to cancel the operation, press the [MENU] button.

3. Use the [VALUE] knob to select "YES," and press the [VALUE] knob.

Formatting is executed. When the operation is finished, the message "COMPLETE" appears.

4. Press the [MENU] button several times to close the menu.

## Backing Up and Restoring the Unit's Settings on a USB Flash Drive

You can group together the unit's settings into a single file (.V1P) and back up it to a USB flash drive connected to the USB MEMORY port. You can access the backed up setting file on the USB flash drive and restore it into the unit for use when needed.

**NOTE**

- When using a USB flash drive for the first time, you must format it using this unit (p. 41).
- Never turn off the power or remove the USB flash drive while the message "PLEASE WAIT" is shown.
- Depending on the USB flash drive, recognition of the flash drive might take some time.

### Backing Up

#### Saving a new file

1. [MENU] button → "USB MEMORY" → select "BACKUP ALL SETTINGS," and press the [VALUE] knob.



The settings files in the USB flash drive are listed.

2. Use the [VALUE] knob to select "NEW FILE..." and press the [VALUE] knob.

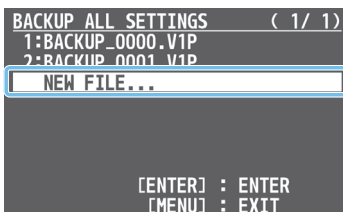

3. Enter the file name.

\* You can enter a text string of up to 16 characters in length.

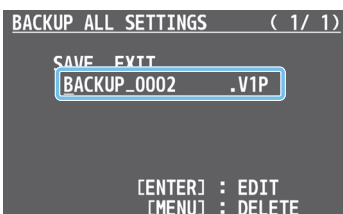

- ① Use the [VALUE] knob to move the cursor.  
Pressing the [MENU] button deletes the character at the cursor location.
- ② Press the [VALUE] knob to highlight the character at the cursor location.
- ③ Use the [VALUE] knob to change the character, and press the [VALUE] knob.

4. When you finish entering the name, use the [VALUE] knob to select "SAVE," and press the [VALUE] knob.

A confirmation message appears.



\* If you want to cancel the operation, press the [MENU] button.

5. Use the [VALUE] knob to select "YES," and press the [VALUE] knob.

The settings file (.V1P) is backed up on the USB flash drive. When the operation is finished, the message "COMPLETE" appears.

6. Press the [MENU] button several times to close the menu.

#### Overwrite-saving

1. [MENU] button → "USB MEMORY" → select "BACKUP ALL SETTINGS," and press the [VALUE] knob.

The settings files in the USB flash drive are listed.

2. Use the [VALUE] knob select the settings file that you want to overwrite, and press the [VALUE] knob.

A confirmation message appears.

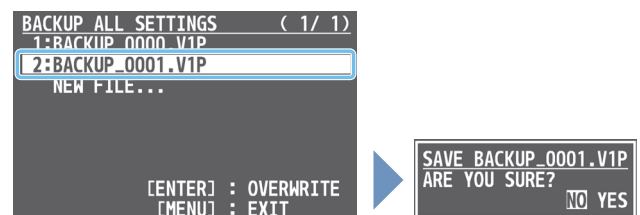

\* If you want to cancel the operation, press the [MENU] button.

3. Use the [VALUE] knob to select "YES," and press the [VALUE] knob.

The settings file is overwrite-saved. When the operation is finished, the message "COMPLETE" appears.

4. Press the [MENU] button several times to close the menu.

**MEMO**

Some settings are not saved to the file.  
See "BACKUP ALL SETTINGS" in "15: USB MEMORY" (p. 57) for details.



## Restoring

Here's how to restore this unit's settings that you saved on a USB flash drive. When you restore settings, the current settings are overwritten.

1. [MENU] button → "USB MEMORY" → select "RESTORE ALL SETTINGS," and press the [VALUE] knob.



The settings files in the USB flash drive are listed.

2. Use the [VALUE] knob to select the file you want to restore, and press the [VALUE] knob.

A confirmation message appears.

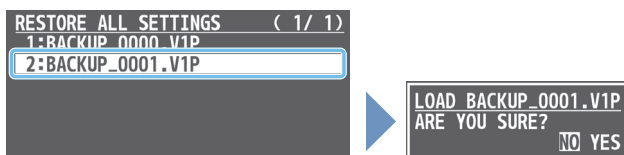

\* If you want to cancel the operation, press the [MENU] button.

3. Use the [VALUE] knob to select "YES," and press the [VALUE] knob.

The settings are restored. When the operation is finished, the message "COMPLETE" appears.

4. Press the [MENU] button several times to close the menu.

## Assigning Different Functions to Control with the [DSK PVW] and [DSK ON] Buttons

You can assign different functions to control with the [DSK PVW] and [DSK ON] buttons.

1. [MENU] button → "SYSTEM" → select "DSK PVW SW ASSIGN" or "DSK ON SW ASSIGN," and press the [VALUE] knob.

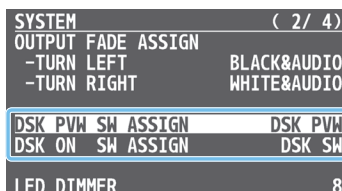

2. Use the [VALUE] knob to select the assign function that you want to assign to the [DSK PVW] or [DSK ON] button.

Value	Explanation
N/A	No function is assigned.
DSK SW	Turns DSK composition on/off. This is the default setting for "DSK ON SW ASSIGN."
DSK PVW	Turns the preview output of the DSK compositing result on/off.
FREEZE	Turns the freeze function on/off.
AUTO SWITCHING	Turns the auto switching function on/off.
BPM TAP	When "TYPE" in the AUTO SWITCHING menu is "BPM SYNC," you can set the BPM according to the tempo at which you press the button. The buttons flash in sync with the current BPM setting.
INPUT 1-4 ASSIGN	The video source assigned to the specified input switches between HDMI and STILL 1 through 4 in order, with each press of the button.
STILL 1-4 OUTPUT	Outputs the specified still image.
INPUT 1-4 MUTE	Turns the mute function on/off for the specified input audio.
AUDIO IN 1, 2 MUTE	
LINE IN MUTE	
MIC/AUXIN MUTE	
OUTPUT MUTE	Turns on/off the mute function for the output audio.
REVERB SW	Turns reverb on/off.
INPUT SCAN N	The final output switches from INPUT 1 → 4 in order, with each press of the button.
INPUT SCAN R	The final output switches from INPUT 4 → 1 in order, with each press of the button.
MEMORY SCAN N	The preset memories 1 → 8 are recalled in order with each press of the button.
MEMORY SCAN R	The preset memories 8 → 1 are recalled in order with each press of the button.
REC START/STOP	Controls the recorder's video record start/stop if a recorder that supports REC control functionality is connected.

3. Press the [MENU] button several times to close the menu.

### MEMO

The USER indicator lights when a different function is assigned to the [DSK PVW] or [DSK ON] button.



## Preventing Unintended Operation (Panel Lock)

You can disable operation of the panel's buttons and knobs to prevent unintended operations (Panel Lock function).

1. [MENU] button → "SYSTEM" → select "PANEL LOCK," and press the [VALUE] knob.

The PANEL LOCK menu appears.

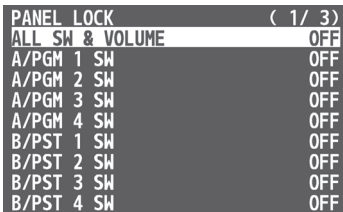
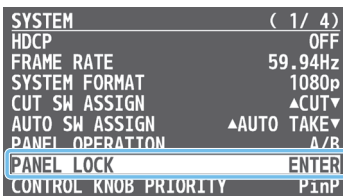

2. Use the [VALUE] knob to select a target for panel lock, and press the [VALUE] knob.

Menu item	Explanation
ALL SW & VOLUME	The following settings are turned on/off together.
A/PGM 1-4 SW	A/PGM cross-point [1]-[4] buttons
B/PST 1-4 SW	B/PST cross-point [1]-[4] buttons
CUT SW	[CUT] button
AUTO SW	[AUTO] button
1/5-4/8 SW	[1/5]-[4/8] buttons
MODE SW	[MODE] button
TRANSITION SW	[TRANSITION] button
VIDEO FADER	Video fader
PinP SW	[PinP] button
SPLIT SW	[SPLIT] knob
CONTROL KNOB	[CONTROL 1] [CONTROL 2] knobs
DSK PVW SW	[DSK PVW] button
DSK ON SW	[DSK ON] button
OUTPUT FADE	[OUTPUT FADE] knob
AUDIO LEVEL	[AUDIO IN 1] [AUDIO IN 2] knobs [LINE IN] [MAIN] knobs
AUDIO GAIN	[AUDIO GAIN 1] [AUDIO GAIN 2] knobs
SETUP (LINK) SW	[SETUP] button
LIMITER SW	[LIMITER] button

3. Turn the [VALUE] knob to specify whether panel lock is enable (ON) or disable (OFF).
4. Press the [MENU] button several times to close the menu.

### MEMO

The [MENU] button blinks when you try to operate a locked button, knob or other control.

## Controlling an External Recorder's Video Record Start/Stop from the Unit

Connect a recorder that supports REC control functionality via HDMI to control REC START/STOP on the recorder from this unit.

For more about recorders that support the REC control function, refer to the Roland website.

<https://proav.roland.com/>

## Settings

### [DSK PVW] and [DSK ON] button functions

To use the REC control function, the REC START/STOP functions must be assigned to the [DSK PVW] or the [DSK ON] button.

- "Assigning Different Functions to Control with the [DSK PVW] and [DSK ON] Buttons" (p. 41)

1. Set the function for the [DSK PVW] or the [DSK ON] button to "REC START/STOP"

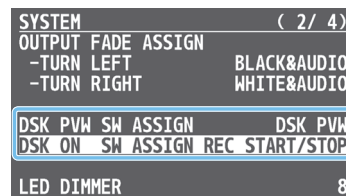

### Turning REC control on/off

1. [MENU] button → "VIDEO OUTPUT" → "OUTPUT 1" or "OUTPUT 2" → and set "REC CONTROL" to "ON."



## Operation

1. Press either the [DSK PVW] or the [DSK ON] button to which REC START/STOP is assigned.

Each time you press the button, the recorder switches between video record start/stop.



### NOTE

The lights of the [DSK PVW] and [DSK ON] buttons show the status of this unit, and are not linked with the recorder's status. For instance, if the recorder stops recording for some reason while the [DSK PVW] or [DSK ON] buttons is lit, these buttons do not automatically go dark in response.

## Returning to the Factory Settings (Factory Reset)

Here's how you can return the settings of this unit to their factory-set state.

If following the procedures described in this manual does not cause the result you expect, try executing a factory reset.

### NOTE

- When you execute factory reset, any previously specified content, any settings saved in preset memory (p. 38), and the still image (p. 20) saved in the unit will all be lost.
- Do not turn off the power while the message "PLEASE WAIT" is shown.

1. [MENU] button → "SYSTEM" → select "FACTORY RESET," and press the [VALUE] knob.

A confirmation message appears.

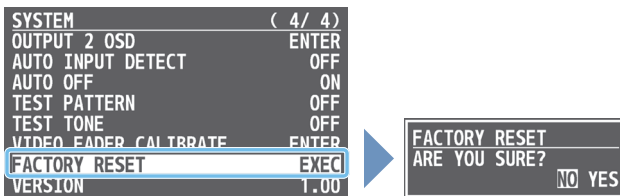

\* If you want to cancel the operation, press the [MENU] button.

2. Use the [VALUE] knob to select "YES," and press the [VALUE] knob.

Factory reset is executed. When the operation is finished, the message "COMPLETE" appears.

3. Press the [MENU] button several times to close the menu.

# Menu List

## 1: VIDEO INPUT

Menu item	Value (bold text: default value)	Explanation
<b>INPUT 1-3</b>	Adjusts the video that is input from the INPUT 1-3 connectors.	
<b>INPUT STATUS (*1)</b>	ENTER	Displays information about the incoming video (format, size, etc.).
<b>INPUT ASSIGN</b>	Selects the video source for INPUT 1-3.	
	<b>HDMI</b>	The video input from the INPUT connector.
	STILL 1-4	The still images saved in this unit.
<b>FLIP H (*1)</b>	<b>OFF</b> , ON	If this is "ON," the video is input with left and right flipped.
<b>FLIP V (*1)</b>	<b>OFF</b> , ON	If this is "ON," the video is input with top and bottom flipped.
<b>BRIGHTNESS (*1)</b>	-32- <b>0</b> -31	Adjusts the brightness.
<b>CONTRAST (*1)</b>	-32- <b>0</b> -31	Adjusts the contrast.
<b>SATURATION (*1)</b>	-32- <b>0</b> -31	Adjusts the saturation.
<b>INPUT 4 (SCALER)</b>	Adjusts the video that is input from the INPUT 4 connector.	
<b>INPUT STATUS (*1)</b>	ENTER	Displays information about the incoming video (format, size, etc.).
<b>INPUT ASSIGN</b>	Selects the video source for INPUT 4.	
	<b>HDMI</b>	The video input from the INPUT 4 connector.
	STILL 1-4	The still images saved in this unit.
<b>FLICKER FILTER (*1)</b>	<b>OFF</b> , ON	If this is "ON," flickering is reduced.
<b>FLIP H (*1)</b>	<b>OFF</b> , ON	If this is "ON," the video is input with left and right flipped.
<b>FLIP V (*1)</b>	<b>OFF</b> , ON	If this is "ON," the video is input with top and bottom flipped.
<b>EDID (*1) (*2)</b>	<b>INTERNAL</b>	Specifies the input format (EDID).
	SVGA (800 x 600)	If this is "INTERNAL," EDID information for all formats that can be input to the unit will be transmitted.  <b>What is EDID?</b> EDID is data that is transmitted from the unit to the source device when the unit is connected to a source device. EDID contains data such as the formats that can be input to the unit (resolution, color space, color depth) and audio information. Based on the EDID information that the source device receives, it will output the most appropriate video format to the unit.
	XGA (1024 x 768)	
	WXGA (1280 x 800)	
	FWXG (1366 x 768)	
	SXGA (1280 x 1024)	
	SXGA+ (1400 x 1050)	
	UXGA (1600 x 1200)	
WUXGA (1920 x 1200)		
720p, 1080i, 1080p		
<b>ZOOM (*1)</b>	10.0- <b>100.0</b> -1000.0% (*3)	Adjusts the zoom ratio.
<b>SCALING TYPE (*1)</b>	Specifies the scaling type.	
	<b>FULL</b>	Always displays the picture expanded to full screen, irrespective of the aspect ratio of the input video.
	LETTERBOX	Enlarges or reduces the incoming video to a full-screen view while keeping the aspect ratio unchanged.
	CROP	Enlarges or reduces the incoming video so that the output picture has no blank margins while keeping the aspect ratio unchanged. Video extending beyond the borders is cut off.
	DOT BY DOT	Performs no scaling.
	MANUAL	Scale according to the "MANUAL SIZE H" and "MANUAL SIZE V" settings below.
<b>MANUAL SIZE H (*4)</b>	-2000- <b>0</b> -2000 (*3)	Adjusts the horizontal size.
<b>MANUAL SIZE V (*4)</b>	-2000- <b>0</b> -2000 (*3)	Adjusts the vertical size.
<b>POSITION H (*1)</b>	-1920- <b>0</b> -1920	Adjusts the position in the horizontal direction.
<b>POSITION V (*1)</b>	-1200- <b>0</b> -1200	Adjusts the position in the vertical direction.
<b>BRIGHTNESS (*1)</b>	-32- <b>0</b> -31	Adjusts the brightness.
<b>CONTRAST (*1)</b>	-32- <b>0</b> -31	Adjusts the contrast.
<b>SATURATION (*1)</b>	-32- <b>0</b> -31	Adjusts the saturation.
<b>RED (*1)</b>	-64- <b>0</b> -63	Adjusts the red level.
<b>GREEN (*1)</b>	-64- <b>0</b> -63	Adjusts the green level.
<b>BLUE (*1)</b>	-64- <b>0</b> -63	Adjusts the blue level.

(\*1) This can be set if "INPUT ASSIGN" is "INPUT ASSIGN."

(\*2) A change in the setting is not applied until you press the [VALUE] knob to confirm.

(\*3) The valid range of setting values depends on conditions such as the input/output format.

(\*4) This can be set if "SCALING TYPE" is "INPUT MANUAL."



## 2: VIDEO OUTPUT

Menu item	Value (bold text: default value)	Explanation
<b>OUTPUT 1, 2</b>	Adjusts the video that is output from the OUTPUT 1 and 2 connectors.	
<b>OUTPUT STATUS</b>	—	Shows the connection status of the OUTPUT connector.
<b>OUTPUT ASSIGN</b>	Specifies the output bus that is assigned to the OUTPUT connector.	
	<b>PROGRAM</b>	Final output video. This is the default setting for "OUTPUT 1."
	PREVIEW	Preview output video (the video to be output next)
	<b>MULTI-VIEW</b>	Multi-view. This is the default setting for "OUTPUT 2."
<b>COLOR SPACE</b>	<b>YPbPr</b> , RGB (0–255), RGB (16–235)	Specifies the color space (system for representing colors in video).
<b>DVI-D/HDMI SIGNAL</b>	<b>HDMI</b> , DVI-D	Specifies the type of output signal.
<b>BRIGHTNESS</b>	-64– <b>0</b> –63	Adjusts the brightness.
<b>CONTRAST</b>	-64– <b>0</b> –63	Adjusts the contrast.
<b>SATURATION</b>	-64– <b>0</b> –63	Adjusts the saturation.
<b>RED</b>	-64– <b>0</b> –63	Adjusts the red level.
<b>GREEN</b>	-64– <b>0</b> –63	Adjusts the green level.
<b>BLUE</b>	-64– <b>0</b> –63	Adjusts the blue level.
<b>REC CONTROL</b>	OFF, <b>ON</b>	Turns the REC control on/off. If this is "ON," REC START/STOP commands can be sent to a recorder that supports REC control functionality. * To use the REC control function, the REC START/STOP functions must be assigned to the [DSK PVW] or the [DSK ON] button. Set the "DSK PVW SW ASSIGN" or "DSK ON SW ASSIGN" in the SYSTEM menu to "REC START/STOP."



## 3: TRANSITION TIME

Menu item	Value (bold text: default value)	Explanation
<b>MIX/WIPE TIME</b>	0.0– <b>1.0</b> –4.0sec	Specifies the video transition time.
<b>PinP TIME</b>	0.0– <b>1.0</b> –4.0sec	For PinP compositing, specifies the fade-in/out time for the inset screen.
<b>DSK TIME</b>	0.0– <b>1.0</b> –4.0sec	For DSK compositing, specifies the fade-in/out time for the overlay logo or video.

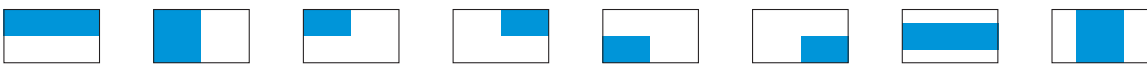
## 4: MIX/WIPE

Menu item	Value (bold text: default value)	Explanation
<b>TRANSITION TYPE</b>	Selects the transition effect. You can also use the [TRANSITION] button to switch between MIX and WIPE.	
	<b>MIX</b>	The two videos are mixed as the transition occurs. 
	WIPE	The next video moves across to replace the original video. 
<b>MIX TYPE</b>	Specifies the transition pattern for mix.	
	<b>MIX</b>	The two videos are mixed as the transition occurs.
	FAM	Video transitions are made with the luminance levels of the two video streams maintained unchanged. This is an abbreviation of "full additive mix."
	NAM	The two video streams are compared, and transitions are made with display during transition starting with levels of high luminance. This is an abbreviation of "non-additive mix."
<b>WIPE TYPE</b>	Specifies the transition pattern for wipe.	
	<b>HORIZONTAL</b> VERTICAL   UPPER LEFT   UPPER RIGHT   LOWER LEFT   LOWER RIGHT   H-CENTER   V-CENTER	
<b>WIPE DIRECTION</b>	NORMAL, REVERSE, <b>ROUND TRIP</b>	Specifies the direction of wipe.
<b>WIPE BORDER COLOR</b>	<b>WHITE</b> , YELLOW, CYAN, GREEN, MAGENTA, RED, BLUE, BLACK, SOFTEGE	Specifies the color of the border added to the edge of the wipe area. If this is set to "SOFTEGE," the wipe border is blurred.
<b>WIPE BORDER WIDTH</b>	0– <b>3</b> –14	Specifies the width of the border added to the edge of the wipe area.

## 5: SPLIT

Menu item	Value (bold text: default value)	Explanation
SPLIT	<b>OFF</b> , ON	Turns the split composition on/off. You can also use the [SPLIT] button to turn this on/off.
SPLIT TYPE	Selects the split composition types. Press and turn the [CONTROL 2] knob to switch between compositing types. (*5)	
	<b>SPLIT V</b>	This vertically crops the center section of the video. 
	SPLIT H	This horizontally crops the center section of the video. 
A-CENTER	-50.0- <b>0.0</b> -50.0%	<ul style="list-style-type: none"> <li>• <b>When at SPLIT V</b> Adjusts the horizontal position of the video placed on the left. You can also adjust this by turning the [CONTROL 1] knob. (*5)</li> <li>• <b>When at SPLIT H</b> Adjusts the horizontal position of the video placed above. You can also adjust this by turning the [CONTROL 2] knob. (*5)</li> </ul> <p>* This positions the A/PGM bus video to the left or upper side.</p>
B-CENTER	-50.0- <b>0.0</b> -50.0%	<ul style="list-style-type: none"> <li>• <b>When at SPLIT V</b> Adjusts the horizontal position of the video placed on the right. You can also adjust this by turning the [CONTROL 1] knob. (*5)</li> <li>• <b>When at SPLIT H</b> Adjusts the horizontal position of the video placed below. You can also adjust this by turning the [CONTROL 2] knob. (*5)</li> </ul> <p>* This positions the B/PST bus video to the right or lower side.</p>
CENTER POSITION	-50.0- <b>0.0</b> -50.0%	Adjusts the position of the boundary. You can adjust this by turning the [CONTROL 1] knob while pressing it.
BORDER COLOR	<b>WHITE</b> , YELLOW, CYAN, GREEN, MAGENTA, RED, BLUE, BLACK	Specifies the color of the border.
BORDER WIDTH	0- <b>3</b> -14	Adjusts the width of the border.

(\*5) When both split and PinP compositing are on, you can operate the effect selected in the SYSTEM menu item "CONTROL KNOB PRIORITY"

## 6: PinP

Menu item	Value (bold text: default value)	Explanation
PinP SOURCE	<b>HDMI 1</b> –4, STILL 1–4	Specifies the video source of the inset screen. When the [MODE] button is lit up yellow, you can select HDMI 1–4 with the [1/5]–[4/8] buttons.
PinP TYPE	Specifies the type of PinP compositing.	
	<b>PinP</b>	Composites the inset screen on top of the background video.
	LUMINANCE-WHITE KEY	A combination of PinP and luminance key (white). Makes the white portions of the inset screen transparent, and composites the image with the background.
	LUMINANCE-BLACK KEY	A combination of PinP and luminance key (black). Makes the black portions of the inset screen transparent, and composites the image with the background.
PinP TARGET	CHROMA KEY	A combination of PinP and chroma key. Makes the specified key color portions of the inset screen transparent, and composites the image with the background.
	Specifies how the unit operates when you press the [PinP] button.	
PinP TARGET	<b>PVW.PGM</b>	Turns PinP composition on/off. When turns on, displays the inset screen on both the preview output and the final output.
	PVW	Turns the inset screen preview output on/off. When turns on, displays the inset screen in only the preview output. Use this to check the composited result before final output. Switching the video with the [AUTO] and [CUT] buttons or the video fader turns PinP compositing on, and the composited result is sent to final output.
When PinP TYPE = PinP		
WINDOW	Adjusts the inset screen.	
POSITION H	-50.0– <b>-40.0</b> –50.0%	Adjusts the horizontal position of the inset screen. You can also adjust this by turning the [CONTROL 1] knob. (*6)
POSITION V	-50.0– <b>-40.0</b> –50.0%	Adjusts the vertical position of the inset screen. You can also adjust this by turning the [CONTROL 2] knob. (*6)
SIZE	10.0– <b>35.0</b> –100.0%	Adjusts the size (zoom) of the inset screen. You can adjust this by turning the [CONTROL 1] knob while pressing it. (*6)
CROPPING H	0.0– <b>100.0%</b>	Adjusts the horizontal size of the inset screen.
CROPPING V	0.0– <b>100.0%</b>	Adjusts the vertical size of the inset screen.
SHAPE	<b>RECTANGLE</b> , CIRCLE, DIAMOND	Specifies the shape of the inset screen.
BORDER COLOR	<b>WHITE</b> , YELLOW, CYAN, GREEN, MAGENTA, RED, BLUE, BLACK, SOFTEDGE	Specifies the color of the border for the inset screen. If this is set to "SOFTEDGE," the edge of the inset screen is blurred.
BORDER WIDTH	0– <b>1</b> –14	Adjusts the width of the border for the inset screen.
VIEW	Adjusts the video that is shown in the inset screen.	
POSITION H	-50.0– <b>0.0</b> –50.0%	Adjusts the horizontal position at which the inset screen is shown.
POSITION V	-50.0– <b>0.0</b> –50.0%	Adjusts the vertical position at which the inset screen is shown.
ZOOM	<b>100</b> –400%	Adjusts the zoom of the video shown in the inset screen. You can adjust this by turning the [CONTROL 2] knob while pressing it. (*6)
When PinP TYPE = LUMINANCE-WHITE KEY or LUMINANCE-BLACK KEY		
WINDOW	Adjusts the inset screen.	
POSITION H	-50.0– <b>-40.0</b> –50.0%	Adjusts the horizontal position of the inset screen. You can also adjust this by turning the [CONTROL 1] knob. (*6)
POSITION V	-50.0– <b>-40.0</b> –50.0%	Adjusts the vertical position of the inset screen. You can also adjust this by turning the [CONTROL 2] knob. (*6)
SIZE	10.0– <b>35.0</b> –100.0%	Adjusts the size (zoom) of the inset screen. You can adjust this by turning the [CONTROL 1] knob while pressing it. (*6)
CROPPING H	0.0– <b>100.0%</b>	Adjusts the horizontal size of the inset screen.
CROPPING V	0.0– <b>100.0%</b>	Adjusts the vertical size of the inset screen.
VIEW	Adjusts the video that is shown in the inset screen.	
POSITION H	-50.0– <b>0.0</b> –50.0%	Adjusts the horizontal position at which the inset screen is shown.
POSITION V	-50.0– <b>0.0</b> –50.0%	Adjusts the vertical position at which the inset screen is shown.
ZOOM	<b>100</b> –400%	Adjusts the zoom of the video shown in the inset screen.
KEY LEVEL	0– <b>64</b> –255	Adjusts the degree of extraction (transparency) for the key. You can adjust this by turning the [CONTROL 2] knob while pressing it. (*6)
KEY GAIN	<b>0</b> –255	Adjusts the degree of edge blur (semi-transmissive region) for the key.
MIX LEVEL	0– <b>255</b>	Adjusts the key's overall density (output level).

(\*6) When both split and PinP compositing are on, you can operate the effect selected in the SYSTEM menu item "CONTROL KNOB PRIORITY."

Menu item	Value (bold text: default value)	Explanation
FILL TYPE	<b>BUS</b> , MATTE	If this is "MATTE," the superimposed logo or video is filled-in with the specified color when using key compositing. The fill-in color is specified by "MATTE COLOR" below.
MATTE COLOR (*7)	WHITE, YELLOW, CYAN, GREEN, MAGENTA, <b>RED</b> , BLUE, BLACK	Specifies the color used when filling-in the superimposed logo or video.
EDGE TYPE	<b>OFF</b> , BORDER, DROP, SHADOW, OUTLINE	Specifies the type of edge applied to the superimposed logo or video.
EDGE COLOR	WHITE, YELLOW, CYAN, GREEN, MAGENTA, RED, BLUE, <b>BLACK</b>	Specifies the color of the edge applied to the superimposed logo or video.
EDGE WIDTH	0- <b>3</b> -14	Specifies the width of the edge applied to the superimposed logo or video.
<b>When PinP TYPE = CHROMA KEY</b>		
WINDOW	Adjusts the inset screen.	
POSITION H	-50.0- <b>-40.0</b> -50.0%	Adjusts the horizontal position of the inset screen. You can also adjust this by turning the [CONTROL 1] knob. (*8)
POSITION V	-50.0- <b>-40.0</b> -50.0%	Adjusts the vertical position of the inset screen. You can also adjust this by turning the [CONTROL 2] knob. (*8)
SIZE	10.0- <b>35.0</b> -100.0%	Adjusts the size (zoom) of the inset screen. You can adjust this by turning the [CONTROL 1] knob while pressing it. (*8)
CROPPING H	0.0- <b>100.0%</b>	Adjusts the horizontal size of the inset screen.
CROPPING V	0.0- <b>100.0%</b>	Adjusts the vertical size of the inset screen.
VIEW	Adjusts the video that is shown in the inset screen.	
POSITION H	-50.0- <b>0.0</b> -50.0%	Adjusts the horizontal position at which the inset screen is shown.
POSITION V	-50.0- <b>0.0</b> -50.0%	Adjusts the vertical position at which the inset screen is shown.
ZOOM	<b>100</b> -400%	Adjusts the zoom of the inset screen. You can adjust this by turning the [CONTROL 2] knob while pressing it. (*8)
KEY LEVEL	0- <b>64</b> -255	Adjusts the degree of extraction (transparency) for the key.
KEY GAIN	0-255	Adjusts the degree of edge blur (semi-transmissive region) for the key.
MIX LEVEL	0- <b>255</b>	Adjusts the key's overall density (output level).
CHROMA	Make detailed settings for chroma key.	
COLOR	GREEN, <b>BLUE</b>	Specifies green or blue as the key color (the color to be removed). If you want a color other than green or blue to turn transparent, use "SAMPLING MARKER" to specify the key color.
HUE WIDTH	-30- <b>0</b> -30	Adjusts the hue width for the key color.
HUE FINE	0- <b>240</b> -360	Adjusts the center position of the hue for the key color.
SATURATION WIDTH	-128- <b>0</b> -127	Adjusts the saturation width for the key color.
SATURATION FINE	0-255	Adjusts the center position of saturation for the key color.
SAMPLING MARKER	<b>OFF</b> , ON	If this is "ON," a sampling marker (  ) is shown on the preview output video for you to sample (detect) the key color. When you execute sampling, the setting automatically turns "OFF."
POSITION H (*9)	-50- <b>0</b> -50%	Adjusts the horizontal position of the sampling marker.
POSITION V (*9)	-50- <b>0</b> -50%	Adjusts the vertical position of the sampling marker.
SAMPLING EXECUTE (*9)	EXEC	Executes key color sampling. The "HUE WIDTH," "HUE FINE," "SATURATION WIDTH," and "SATURATION FINE" settings are adjusted automatically.
FILL TYPE	<b>BUS</b> , MATTE	If this is "MATTE," the superimposed logo or video is filled-in with the specified color when using key compositing. The fill-in color is specified by "MATTE COLOR" below.
MATTE COLOR (*7)	WHITE, YELLOW, CYAN, GREEN, MAGENTA, <b>RED</b> , BLUE, BLACK	Specifies the color used when filling-in the superimposed logo or video.
EDGE TYPE	<b>OFF</b> , BORDER, DROP, SHADOW, OUTLINE	Specifies the type of edge applied to the superimposed logo or video.
EDGE COLOR	WHITE, YELLOW, CYAN, GREEN, MAGENTA, RED, BLUE, <b>BLACK</b>	Specifies the color of the edge applied to the superimposed logo or video.
EDGE WIDTH	0- <b>3</b> -14	Specifies the width of the edge applied to the superimposed logo or video.

(\*7) This can be set if "FILL TYPE" is "MATTE."

(\*8) When both split and PinP compositing are on, you can operate the effect selected in the SYSTEM menu item "CONTROL KNOB PRIORITY."

(\*9) This can be set if "SAMPLING MARKER" is "ON."



## 7: DSK

Menu item	Value (bold text: default value)	Explanation
DSK PVW	OFF, <b>ON</b>	Turns the preview output of the DSK compositing result on/off. If "DSK PVW" function is assigned to the [DSK PVW] button, you can also switch this by pressing the button.
DSK	OFF, <b>ON</b>	Turns DSK composition on/off. If "DSK ON" function is assigned to the [DSK ON] button, you can also switch this by pressing the button.
KEY SOURCE	<b>HDMI 1-4</b> , STILL 1-4	Specifies the source of the logo or video that is overlaid when using DSK compositing.
KEY TYPE	Specifies the DSK type used during DSK composition.	
	LUMINANCE-WHITE	Composite using luminance key. Makes white portions transparent according to brightness.
	<b>LUMINANCE-BLACK</b>	Composite using luminance key. Makes black portions transparent according to brightness.
	CHROMA	Composite using chroma key. Makes the specified key color transparent according to hue.
KEY LEVEL	0- <b>64</b> -255	Adjusts the degree of extraction (transparency) for the key.
KEY GAIN	<b>0</b> -255	Adjusts the degree of edge blur (semi-transmissive region) for the key.
MIX LEVEL	0- <b>255</b>	Adjusts the key's overall density (output level).
CHROMA	Make detailed settings for chroma key.	
COLOR (*10)	GREEN, <b>BLUE</b>	Specifies green or blue as the key color (the color to be removed). If you want a color other than green or blue to turn transparent, use "SAMPLING MARKER" to specify the key color.
HUE WIDTH (*10)	-30- <b>0</b> -30	Adjusts the hue width for the key color.
HUE FINE (*10)	0- <b>240</b> -360	Adjusts the center position of the hue for the key color.
SATURATION WIDTH (*10)	-128- <b>0</b> -127	Adjusts the saturation width for the key color.
SATURATION FINE (*10)	<b>0</b> -255	Adjusts the center position of saturation for the key color.
SAMPLING MARKER (*10)	<b>OFF</b> , ON	If this is "ON," a sampling marker (  ) is shown on the preview output video for you to sample (detect) the key color. When you execute sampling, the setting automatically turns "OFF."
POSITION H (*11)	-50- <b>0</b> -50%	Adjusts the horizontal position of the sampling marker.
POSITION V (*11)	-50- <b>0</b> -50%	Adjusts the vertical position of the sampling marker.
SAMPLING EXECUTE (*11)	EXEC	Executes key color sampling. The "HUE WIDTH," "HUE FINE," "SATURATION WIDTH," and "SATURATION FINE" settings are adjusted automatically.
FILL TYPE	<b>BUS</b> , MATTE	If this is "MATTE," the superimposed logo or video is filled-in with the specified color when using key compositing. The fill-in color is specified by "MATTE COLOR" below.
MATTE COLOR (*12)	WHITE, YELLOW, CYAN, GREEN, MAGENTA, <b>RED</b> , BLUE, BLACK	Specifies the color used when filling-in the superimposed logo or video.
EDGE TYPE	<b>OFF</b> , BORDER, DROP, SHADOW, OUTLINE	Specifies the type of edge applied to the superimposed logo or video.
EDGE COLOR	WHITE, YELLOW, CYAN, GREEN, MAGENTA, RED, BLUE, <b>BLACK</b>	Specifies the color of the edge applied to the superimposed logo or video.
EDGE WIDTH	0- <b>3</b> -14	Specifies the width of the edge applied to the superimposed logo or video.

(\*10) This can be set if "KEY TYPE" is "CHROMA."

(\*11) This can be set if "SAMPLING MARKER" is "ON."

(\*12) This can be set if "FILL TYPE" is "MATTE."

## 8: AUDIO INPUT

Menu item	Value (bold text: default value)	Explanation	
INPUT 1–4	Adjusts the audio that is input from the INPUT 1–4 connectors (HDMI).		
DIGITAL GAIN	-42.0– <b>0.0</b> –42.0dB	Adjusts the digital gain.	
INPUT LEVEL	-INF– <b>0.0</b> –10.0dB	Adjusts the input volume.	
INPUT MUTE	<b>OFF</b> , ON	Turns the mute function on/off. If this is “ON,” the input audio is temporarily silenced.	
SOLO	<b>OFF</b> , ON	Turns the solo function on/off. Only the audio for which this is “ON” is heard in the headphones. * The solo function applies to the headphone output. It does not affect output other than the headphones.	
MONO	Converts the input audio from stereo to mono.		
	<b>OFF</b>	Sends the stereo input audio without change.	
	L MONO	The audio of the L channel is sent to both L and R.	
	R MONO	The audio of the R channel is sent to both L and R.	
	LR MIX	The audio of the L channel and R channel is mixed, and sent to both L and R.	
REVERB SEND	<b>0</b> –127	Adjusts the amount of audio sent to reverb.	
DELAY	<b>0.0</b> –500msec ( <b>0</b> –25.0/29.9frame)	Adjusts the delay time of the audio. <b>Effect</b> Outputs audio with a delay.	
	Specifies an effect preset (high-pass filter, noise gate, compressor, and equalizer). * When you change an effect preset, the settings of each effect are overwritten.		
EFFECT PRESET	<b>DEFAULT</b>	For line input (default setting)	
	MEETING	For meetings	
	INTERVIEW	For interviews	
	AMBIENT MIC	For capturing ambient sound	
HIGH PASS FILTER 80Hz	<b>OFF</b> , ON	Turns the high-pass filter on/off. <b>Effect</b> Cuts off unneeded low-band audio. The cutoff frequency is 80 Hz.	
	NOISE GATE	<b>OFF</b> , ON	Turns the noise gate on/off. <b>Effect</b> Eliminates audio that is lower than the specified threshold level. This is effective when the noise that you want to remove is separate from the audio that you want to keep, and can be used to remove hiss or other noise that is heard during periods of silence.
THRESHOLD		-80– <b>-48</b> –0dB	Specifies the level used as the threshold for removing audio. Audio below the level set here is removed.
RELEASE		30– <b>500</b> –5000ms	Adjusts the length of time until the audio is fully attenuated after audio falls below the threshold.
COMPRESSOR	<b>OFF</b> , ON	Turns the compressor on/off. <b>Effect</b> Audio that exceeds the specified threshold level is compressed. This reduces the difference between the maximum volume and minimum volume, making the audio more comfortable for listening.	
	THRESHOLD	-50– <b>-8</b> –0dB	Specifies the level used as the threshold at which the compressor is applied. Compression is applied to audio that exceeds the threshold.
	RATIO	1.00 : 1, 1.12 : 1, 1.25 : 1, 1.40 : 1, 1.60 : 1, 1.80 : 1, 2.00 : 1, <b>2.50 : 1</b> , 3.20 : 1, 4.00 : 1, 5.60 : 1, 8.00 : 1, 16.0 : 1, INF : 1	Specifies the degree of compression applied to the audio. The state in which no compression is applied is defined as “1.”
	ATTACK	0.0– <b>30</b> –100ms	Specifies the time until compression starts when audio exceeding the threshold is input.
	RELEASE	30– <b>250</b> –5000ms	Adjusts the length of time until compression ends after audio falls below the threshold.
	MAKEUP GAIN	-40– <b>0</b> –40dB	Adjusts the final output volume level after applying the compressor.
EQUALIZER	<b>OFF</b> , ON	Turns the equalizer on/off. <b>Effect</b> Adjusts the volume for each frequency band.	
	Hi GAIN	-15.0– <b>0.0</b> –15.0dB	Boosts or attenuates the high band.
	Hi FREQUENCY	1.0– <b>10.0</b> –20.0kHz	Adjusts the center frequency when changing the volume in the high band.
	Mid GAIN	-15.0– <b>0.0</b> –15.0dB	Boosts or attenuates the middle band.
	Mid FREQUENCY	20.0Hz– <b>2.00kHz</b> –20.0kHz	Adjusts the center frequency when changing the volume in the middle band.
	Mid Q	0.5– <b>1.0</b> –16.0	Adjusts the width of the frequency band when boosting or attenuating the middle band.
	Lo GAIN	-15.0– <b>0.0</b> –15.0dB	Boosts or attenuates the low band.
	Lo FREQUENCY	20.0Hz– <b>100Hz</b> –2.00kHz	Adjusts the center frequency when changing the volume in the low band.

Menu item	Value (bold text: default value)	Explanation	
AUDIO IN 1, 2 AUDIO IN 1/2 (LINKED)	Adjusts the audio that is input from the AUDIO IN 1 and 2 jacks. * "AUDIO IN 1/2 (LINKED)" is shown when "SETUP (LINK) SW" is "ON."		
ANALOG GAIN	<b>0</b> -64dB	Adjusts the input gain (sensitivity) in the analog domain. This can also be adjusted by the [GAIN 1] or [GAIN 2] knob. (*13)	
DIGITAL GAIN	-42.0- <b>0.0</b> -42.0dB	Adjusts the input gain (sensitivity) in the digital domain (after conversion from analog to digital).	
INPUT LEVEL	-INF- <b>0.0</b> -10.0dB	Adjusts the input volume. This can also be adjusted by the [AUDIO IN 1] or [AUDIO IN 2] knob. (*13)	
INPUT MUTE	<b>OFF</b> , ON	Turns the mute function on/off. If this is "ON," the input audio is temporarily silenced.	
SOLO	<b>OFF</b> , ON	Turns the solo function on/off. Only the audio for which this is "ON" is heard in the headphones. * The solo function applies to the headphone output. It does not affect output other than the headphones.	
PHANTOM +48V (*14)	<b>OFF</b> , ON	Turns the phantom power on/off. If this is "ON," phantom power is supplied via the AUDIO IN jacks.	
SETUP (LINK) SW	<b>OFF</b> , ON	Turns the stereo link function on/off. If this is "ON," AUDIO IN 1 and 2 are linked, and operate as a stereo channel. Long-press the [SETUP] button to turn the stereo link function on/off.	
PAN (*15)	L50- <b>CENTER</b> -R50	Adjusts the stereo position (pan).	
REVERB SEND	<b>OFF</b> , ON	Adjusts the amount of audio sent to reverb.	
DELAY	<b>0.0</b> -500msec ( <b>0</b> -25.0/29.9frame)	Adjusts the delay time of the audio. Effect Outputs audio with a delay.	
EFFECT PRESET	Specifies an effect preset (high-pass filter, noise gate, de-esser, compressor, and equalizer). * When you change an effect preset, the settings of each effect are overwritten.		
	<b>DEFAULT</b>	For line input (default setting)	
	MEETING	For meetings	
	INTERVIEW	For interviews	
AMBIENT MIC	For capturing ambient sound		
HIGH PASS FILTER 80Hz	<b>OFF</b> , ON	Turns the high-pass filter on/off. Effect Cuts off unneeded low-band audio. The cutoff frequency is 80 Hz.	
NOISE GATE	<b>OFF</b> , ON	Turns the noise gate on/off. Effect Eliminates audio that is lower than the specified threshold level. This is effective when the noise that you want to remove is separate from the audio that you want to keep, and can be used to remove hiss or other noise that is heard during periods of silence.	
	THRESHOLD	-80- <b>-48</b> -0dB	Specifies the level used as the threshold for removing audio. Audio below the level set here is removed.
	RELEASE	30- <b>500</b> -5000ms	Adjusts the length of time until the audio is fully attenuated after audio falls below the threshold.
DE-ESSER	<b>OFF</b> , ON	Turns the de-esser on/off. Effect Reduces sibilant noise (the sounds you hear when pronouncing "s" words and other hissing sounds).	
	SENS	0- <b>80</b> -100	Adjusts the sensitivity with which sibilants are detected.
	DEPTH	0- <b>64</b> -100	Adjusts the intensity of the effect.
COMPRESSOR	<b>OFF</b> , ON	Turns the compressor on/off. Effect Audio that exceeds the specified threshold level is compressed. This reduces the difference between the maximum volume and minimum volume, making the audio more comfortable for listening.	
	THRESHOLD	-50- <b>-8</b> -0dB	Specifies the level used as the threshold at which the compressor is applied. Compression is applied to audio that exceeds the threshold.
	RATIO	1.00 : 1, 1.12 : 1, 1.25 : 1, 1.40 : 1, 1.60 : 1, 1.80 : 1, 2.00 : 1, <b>2.50 : 1</b> , 3.20 : 1, 4.00 : 1, 5.60 : 1, 8.00 : 1, 16.0 : 1, INF : 1	Specifies the degree of compression applied to the audio. The state in which no compression is applied is defined as "1."
	ATTACK	0.0- <b>30</b> -100ms	Specifies the time until compression starts when audio exceeding the threshold is input.
	RELEASE	30- <b>250</b> -5000ms	Adjusts the length of time until compression ends after audio falls below the threshold.
	MAKEUP GAIN	-40- <b>0</b> -40dB	Adjusts the final output volume level after applying the compressor.
	EQUALIZER	<b>OFF</b> , ON	Turns the equalizer on/off. Effect Adjusts the volume for each frequency band.
Hi GAIN		-15.0- <b>0.0</b> -15.0dB	Boosts or attenuates the high band.
Hi FREQUENCY		1.0- <b>10.0</b> -20.0kHz	Adjusts the center frequency when changing the volume in the high band.
Mid GAIN		-15.0- <b>0.0</b> -15.0dB	Boosts or attenuates the middle band.
Mid FREQUENCY		20.0Hz- <b>500Hz</b> -20.0kHz	Adjusts the center frequency when changing the volume in the middle band.
Mid Q		0.5- <b>1.0</b> -16.0	Adjusts the width of the frequency band when boosting or attenuating the middle band.
Lo GAIN		-15.0- <b>0.0</b> -15.0dB	Boosts or attenuates the low band.
Lo FREQUENCY		20.0Hz- <b>500Hz</b> -20.0kHz	Adjusts the center frequency when changing the volume in the low band.

(\*13) The [GAIN 2] and [AUDIO IN 2] knobs are disabled when "SETUP (LINK) SW" is "ON."

(\*14) Changing "SETUP (LINK) SW" settings automatically turns "PHANTOM +48V" settings "OFF."

(\*15) This can be set if "SETUP (LINK) SW" is "OFF."

Menu item	Value (bold text: default value)	Explanation	
<b>LINE IN</b>	Adjusts the audio that is input from the LINE IN jacks.		
DIGITAL GAIN	-42- <b>0.0</b> -42dB	Adjusts the digital gain.	
INPUT LEVEL	-INF- <b>0.0</b> -10.0dB	Adjusts the input volume.	
INPUT MUTE	<b>OFF</b> , ON	Turns the mute function on/off. If this is "ON," the input audio is temporarily silenced.	
SOLO	<b>OFF</b> , ON	Turns the solo function on/off. Only the audio for which this is "ON" is heard in the headphones. * The solo function applies to the headphone output. It does not affect output other than the headphones.	
MONO	Converts the input audio from stereo to mono.		
	<b>OFF</b>	Sends the stereo input audio without change.	
	L MONO	The audio of the L channel is sent to both L and R.	
	R MONO	The audio of the R channel is sent to both L and R.	
LR MIX	The audio of the L channel and R channel is mixed, and sent to both L and R.		
REVERB SEND	<b>0</b> -127	Adjusts the amount of audio sent to reverb.	
DELAY	<b>0.0</b> -500msec ( <b>0</b> -25.0/29.9frame)	Adjusts the delay time of the audio. <b>Effect</b> Outputs audio with a delay.	
EFFECT PRESET	Specifies an effect preset (high-pass filter, noise gate, compressor, and equalizer). * When you change an effect preset, the settings of each effect are overwritten.		
	<b>DEFAULT</b>	For line input (default setting)	
	MEETING	For meetings	
	INTERVIEW	For interviews	
AMBIENT MIC	For capturing ambient sound		
HIGH PASS FILTER 80Hz	<b>OFF</b> , ON	Turns the high-pass filter on/off. <b>Effect</b> Cuts off unneeded low-band audio. The cutoff frequency is 80 Hz.	
NOISE GATE	<b>OFF</b> , ON	Turns the noise gate on/off. <b>Effect</b> Eliminates audio that is lower than the specified threshold level. This is effective when the noise that you want to remove is separate from the audio that you want to keep, and can be used to remove hiss or other noise that is heard during periods of silence.	
	THRESHOLD	-80- <b>-48</b> -0dB	Specifies the level used as the threshold for removing audio. Audio below the level set here is removed.
	RELEASE	30- <b>500</b> -5000ms	Adjusts the length of time until the audio is fully attenuated after audio falls below the threshold.
COMPRESSOR	<b>OFF</b> , ON	Turns the compressor on/off. <b>Effect</b> Audio that exceeds the specified threshold level is compressed. This reduces the difference between the maximum volume and minimum volume, making the audio more comfortable for listening.	
	THRESHOLD	-50- <b>-8</b> -0dB	Specifies the level used as the threshold at which the compressor is applied. Compression is applied to audio that exceeds the threshold.
	RATIO	1.00 : 1, 1.12 : 1, 1.25 : 1, 1.40 : 1, 1.60 : 1, 1.80 : 1, 2.00 : 1, <b>2.50 : 1</b> , 3.20 : 1, 4.00 : 1, 5.60 : 1, 8.00 : 1, 16.0 : 1, INF : 1	Specifies the degree of compression applied to the audio. The state in which no compression is applied is defined as "1."
	ATTACK	0.0- <b>30</b> -100ms	Specifies the time until compression starts when audio exceeding the threshold is input.
	RELEASE	30- <b>250</b> -5000ms	Adjusts the length of time until compression ends after audio falls below the threshold.
	MAKEUP GAIN	-40- <b>0</b> -40dB	Adjusts the final output volume level after applying the compressor.
	EQUALIZER	<b>OFF</b> , ON	Turns the equalizer on/off. <b>Effect</b> Adjusts the volume for each frequency band.
Hi GAIN	-15.0- <b>0.0</b> -15.0dB	Boosts or attenuates the high band.	
Hi FREQUENCY	1.0- <b>10.0</b> -20.0kHz	Adjusts the center frequency when changing the volume in the high band.	
Mid GAIN	-15.0- <b>0.0</b> -15.0dB	Boosts or attenuates the middle band.	
Mid FREQUENCY	20.0Hz- <b>2.00kHz</b> -20.0kHz	Adjusts the center frequency when changing the volume in the middle band.	
Mid Q	0.5- <b>1.0</b> -16.0	Adjusts the width of the frequency band when boosting or attenuating the middle band.	
Lo GAIN	-15.0- <b>0.0</b> -15.0dB	Boosts or attenuates the low band.	
Lo FREQUENCY	20.0Hz- <b>100Hz</b> -2.00kHz	Adjusts the center frequency when changing the volume in the low band.	
<b>MIC/AUX IN</b>	Adjusts the audio that is input from the MIC/AUX IN jack.		
ANALOG GAIN	<b>0</b> -55dB	Adjusts the input gain (sensitivity) in the analog domain.	
DIGITAL GAIN	-42.0- <b>0.0</b> -42.0dB	Adjusts the input gain (sensitivity) in the digital domain (after conversion from analog to digital).	
INPUT LEVEL	-INF- <b>0.0</b> -10.0dB	Adjusts the input volume. This can also be adjusted by the [MIC/AUX IN] knob.	
INPUT MUTE	<b>OFF</b> , ON	Turns the mute function on/off. If this is "ON," the input audio is temporarily silenced.	
SOLO	<b>OFF</b> , ON	Turns the solo function on/off. Only the audio for which this is "ON" is heard in the headphones. * The solo function applies to the headphone output. It does not affect output other than the headphones.	
PLUG-IN POWER	<b>OFF</b> , ON	Turns the plug-in power on/off. If this is "ON," plug-in power is supplied via the MIC/AUX IN jack.	

Menu item	Value (bold text: default value)	Explanation	
MONO	Converts the input audio from stereo to mono.		
	<b>OFF</b>	Sends the stereo input audio without change.	
	L MONO	The audio of the L channel is sent to both L and R.	
	R MONO	The audio of the R channel is sent to both L and R.	
REVERB SEND	<b>0</b> -127	Adjusts the amount of audio sent to reverb.	
DELAY	<b>0.0</b> -500msec ( <b>0</b> -25.0/29.9frame)	Adjusts the delay time of the audio. <b>Effect</b> Outputs audio with a delay.	
EFFECT PRESET	Specifies an effect preset (high-pass filter, noise gate, de-esser, compressor, and equalizer). * When you change an effect preset, the settings of each effect are overwritten.		
	<b>DEFAULT</b>	For line input (default setting)	
	MEETING	For meetings	
	INTERVIEW	For interviews	
AMBIENT MIC	For capturing ambient sound		
HIGH PASS FILTER 80Hz	<b>OFF</b> , ON	Turns the high-pass filter on/off. <b>Effect</b> Cuts off unneeded low-band audio. The cutoff frequency is 80 Hz.	
NOISE GATE	<b>OFF</b> , ON	Turns the noise gate on/off. <b>Effect</b> Eliminates audio that is lower than the specified threshold level. This is effective when the noise that you want to remove is separate from the audio that you want to keep, and can be used to remove hiss or other noise that is heard during periods of silence.	
	THRESHOLD	-80- <b>-48</b> -0dB	Specifies the level used as the threshold for removing audio. Audio below the level set here is removed.
	RELEASE	30- <b>500</b> -5000ms	Adjusts the length of time until the audio is fully attenuated after audio falls below the threshold.
DE-ESSER	<b>OFF</b> , ON	Turns the de-esser on/off. <b>Effect</b> Reduces sibilant noise (the sounds you hear when pronouncing "s" words and other hissing sounds).	
	SENS	0- <b>80</b> -100	Adjusts the sensitivity with which sibilants are detected.
	DEPTH	0- <b>64</b> -100	Adjusts the intensity of the effect.
COMPRESSOR	<b>OFF</b> , ON	Turns the compressor on/off. <b>Effect</b> Audio that exceeds the specified threshold level is compressed. This reduces the difference between the maximum volume and minimum volume, making the audio more comfortable for listening.	
	THRESHOLD	-50- <b>-8</b> -0dB	Specifies the level used as the threshold at which the compressor is applied. Compression is applied to audio that exceeds the threshold.
	RATIO	1.00 : 1, 1.12 : 1, 1.25 : 1, 1.40 : 1, 1.60 : 1, 1.80 : 1, 2.00 : 1, <b>2.50 : 1</b> , 3.20 : 1, 4.00 : 1, 5.60 : 1, 8.00 : 1, 16.0 : 1, INF : 1	Specifies the degree of compression applied to the audio. The state in which no compression is applied is defined as "1."
	ATTACK	0.0- <b>30</b> -100ms	Specifies the time until compression starts when audio exceeding the threshold is input.
	RELEASE	30- <b>250</b> -5000ms	Adjusts the length of time until compression ends after audio falls below the threshold.
	MAKEUP GAIN	-40- <b>0</b> -40dB	Adjusts the final output volume level after applying the compressor.
EQUALIZER	<b>OFF</b> , ON	Turns the equalizer on/off. <b>Effect</b> Adjusts the volume for each frequency band.	
	Hi GAIN	-15.0- <b>0.0</b> -15.0dB	Boosts or attenuates the high band.
	Hi FREQUENCY	1.0- <b>10.0</b> -20.0kHz	Adjusts the center frequency when changing the volume in the high band.
	Mid GAIN	-15.0- <b>0.0</b> -15.0dB	Boosts or attenuates the middle band.
	Mid FREQUENCY	20.0Hz- <b>500Hz</b> -20.0kHz	Adjusts the center frequency when changing the volume in the middle band.
	Mid Q	0.5- <b>1.0</b> -16.0	Adjusts the width of the frequency band when boosting or attenuating the middle band.
	Lo GAIN	-15.0- <b>0.0</b> -15.0dB	Boosts or attenuates the low band.
	Lo FREQUENCY	20.0Hz- <b>500Hz</b> -20.0kHz	Adjusts the center frequency when changing the volume in the low band.
MUTE/SOLO	Adjusts the mute/solo function for the input audio. * This menu is derived from the "INPUT MUTE" and "SOLO" items in each input audio menu. The settings work in conjunction with each other.		
INPUT 1-4 MUTE	<b>OFF</b> , ON	Turns the mute function on/off. If this is "ON," the input audio is temporarily silenced. If the mute function is assigned to the [DSK PVW] or [DSK ON] button, you can also switch this by pressing the button.	
AUDIO IN 1, 2 MUTE	<b>OFF</b> , ON		
LINE IN MUTE	<b>OFF</b> , ON		
MIC/AUX IN MUTE	<b>OFF</b> , ON		
INPUT 1-4 SOLO	<b>OFF</b> , ON	Turns the solo function on/off. Only the audio for which this is "ON" is heard in the headphones. * The solo function applies to the headphone output. It does not affect output other than the headphones.	
AUDIO IN 1, 2 SOLO	<b>OFF</b> , ON		
LINE IN SOLO	<b>OFF</b> , ON		
MIC/AUX IN SOLO	<b>OFF</b> , ON		
SOLO CLEAR	ENTER	Turns all solo settings off at once.	

## 9: AUDIO OUTPUT

Menu item	Value (bold text: default value)	Explanation
<b>MAIN OUTPUT</b> Adjusts the audio that is output from the AUDIO OUT jacks.		
OUTPUT LEVEL	-INF- <b>0.0</b> -10.0dB	Adjusts the output volume. This can also be adjusted by the [MAIN] knob.
OUTPUT MUTE	<b>OFF</b> , ON	Turns the mute function on/off. If this is "ON," the output audio is temporarily silenced. If the mute function is assigned to the [DSK PVW] or [DSK ON] button, you can also switch this by pressing the button.
LIMITER	<b>OFF</b> , ON	Turns the limiter on/off. You can also use the [LIMITER] button to turn this on/off. <b>Effect</b> Limits the output volume so that it does not exceed the specified threshold level. * Distortion will occur if audio that exceeds the allowable range of the limiter is input.
THRESHOLD	-40.0- <b>-6.0</b> -0.0dB	Adjusts the level that becomes the threshold at which the limiter is applied. Compression is applied to audio that exceeds the threshold. The volume level of audio that is output is limited so as to stay to below the threshold.
<b>EQUALIZER</b> Turns the equalizer on/off. <b>Effect</b> Adjusts the volume for each frequency band.		
Hi GAIN	-15.0- <b>0.0</b> -15.0dB	Boosts or attenuates the high band.
Hi FREQUENCY	1.0- <b>10.0</b> -20.0kHz	Adjusts the center frequency when changing the volume in the high band.
Mid GAIN	-15.0- <b>0.0</b> -15.0dB	Boosts or attenuates the middle band.
Mid FREQUENCY	20.0Hz- <b>500Hz</b> - 20.0kHz	Adjusts the center frequency when changing the volume in the middle band.
Mid Q	0.5- <b>1.0</b> -16.0	Adjusts the width of the frequency band when boosting or attenuating the middle band.
Lo GAIN	-15.0- <b>0.0</b> -15.0dB	Boosts or attenuates the low band.
Lo FREQUENCY	20.0Hz- <b>500Hz</b> -20.0kHz	Adjusts the center frequency when changing the volume in the low band.
<b>COMPRESSOR</b> Turns the compressor on/off. <b>Effect</b> Audio that exceeds the specified threshold level is compressed. This reduces the difference between the maximum volume and minimum volume, making the audio more comfortable for listening		
THRESHOLD	-40.0- <b>-20.0</b> -0.0dB	Specifies the level used as the threshold at which the compressor is applied. Compression is applied to audio that exceeds the threshold.
RATIO	1.00 : 1, 1.12 : 1, 1.25 : 1, 1.40 : 1, 1.60 : 1, 1.80 : 1, 2.00 : 1, 2.50 : 1, <b>3.20 : 1</b> , 4.00 : 1, 5.60 : 1, 8.00 : 1, 16.0 : 1, INF : 1	Specifies the degree of compression applied to the audio. The state in which no compression is applied is defined as "1."
ATTACK	0.0- <b>30</b> -100ms	Specifies the time until compression starts when audio exceeding the threshold is input.
RELEASE	30- <b>250</b> -5000ms	Adjusts the length of time until compression ends after audio falls below the threshold.
MAKEUP GAIN	-40- <b>0</b> -40dB	Adjusts the final output volume level after applying the compressor.
<b>PHONES</b> Settings the audio that is output from the PHONES jack.		
OUTPUT LEVEL	<b>0.0</b> -127	Adjusts the output volume. This can also be adjusted by the [PHONES] knob.
<b>SOLO SETUP</b> Specifies how to select the HDMI audio that is targeted by the solo function.		
HDMI SOLO	<b>NORMAL</b>	The solo function is turned on/off from the AUDIO menu.
	USE CROSS-POINT SW	The solo function turns on while holding down the crosspoint button. You can monitor the audio of the final output video or preview output video while the button is pressed.
<b>REVERB</b> Adds reverberation to the sound.		
REVERB	<b>OFF</b> , ON	Turns reverb on/off.
LEVEL	<b>0</b> -127	Specifies the amount of sound that is returned from the reverb (return level). This adjusts the depth of the overall reverb.
TYPE	Specifies the reverb type.	
	<b>ROOM</b>	Produces the natural-sounding reverberation of a room.
	HALL	Produces the reverberation that is typical of a performance in a concert hall.
SIZE	1- <b>10</b> -20	Specifies the size of the room. The larger the value, the longer the reverb time.

## 10: AUDIO FOLLOW

Menu item	Value (bold text: default value)	Explanation
ALL AUDIO FOLLOW	<b>OFF</b> , ON	Turns on/off the audio follow function for INPUT 1–4 in a single action.
INPUT 1–4	Turns the audio follow function on/off. Audio follow is a function that automatically switches the audio output in tandem with video switching.	
	<b>OFF</b>	The audio is always output regardless of the video selection.
	ON	The audio is output only when the video is selected. The audio is automatically muted if another video is selected.
AUDIO IN 1, 2	<b>OFF</b> , INPUT 1–4	For each audio source, these settings specify the input video (INPUT 1–4) that will use the audio follow function. Audio is output only when the specified input video is selected. If this is "OFF," the audio is always output regardless of the video selection.
LINE IN		
MIC/AUX IN		

## 11: PRESET MEMORY

Menu item	Value (bold text: default value)	Explanation														
LOAD	<b>MEMORY 1–8</b>	Selects the preset memory to load. Pressing the [VALUE] knob lets you load the preset memory. When the [MODE] button is lit up blue, you can recall the preset memories with the [1/5]–[4/8] buttons.														
SAVE	<b>MEMORY 1–8</b>	Selects a preset memory for saving settings. Pressing the [VALUE] knob lets you save the settings to the preset memory. When the [MODE] button is lit up blue, long-press one of the [1/5]–[4/8] buttons to save the settings to the respective preset memory. * The following settings are not saved in preset memory. <table border="1" data-bbox="687 1077 1264 1256"> <tr> <td>AUDIO OUTPUT</td> <td>PHONES</td> <td>OUTPUT LEVEL</td> </tr> <tr> <td></td> <td>AUDIO IN 1, 2</td> <td>SETUP (LINK) SW</td> </tr> <tr> <td></td> <td></td> <td>PHANTOM +48V</td> </tr> <tr> <td>PRESET MEMORY</td> <td colspan="2" rowspan="3">All menu items</td> </tr> <tr> <td>STILL IMAGE</td> </tr> <tr> <td>SYSTEM</td> </tr> </table>	AUDIO OUTPUT	PHONES	OUTPUT LEVEL		AUDIO IN 1, 2	SETUP (LINK) SW			PHANTOM +48V	PRESET MEMORY	All menu items		STILL IMAGE	SYSTEM
AUDIO OUTPUT	PHONES	OUTPUT LEVEL														
	AUDIO IN 1, 2	SETUP (LINK) SW														
		PHANTOM +48V														
PRESET MEMORY	All menu items															
STILL IMAGE																
SYSTEM																
INITIALIZE	<b>MEMORY 1–8</b>	Selects the preset memory to be initialized. Press the [VALUE] knob to initialize the preset memory.														
NAME EDIT	<b>MEMORY 1–8</b> * MEMORY 1–8 shows the name that you specify in NAME EDIT.	Selects the preset memory to be renamed. Press the [VALUE] knob to edit the name.														
START UP	Specifies the settings loaded at startup.															
	<b>LAST MEMORY</b>	Restores the state that was in effect immediately before the power was turned off (Last Memory feature). The current settings (Last Memory values) are saved every 4 seconds, and when you exit a menu.														
	MEMORY 1–8	Recall the settings at the selected preset memory.														
MEMORY PROTECT	<b>OFF</b> , ON	If this is "ON," prohibits settings from being saved or initialized. This protects the preset memories. * Protected preset memories are erased if you perform a factory reset.														
PinP FADE TIME	<b>0.0</b> –1.0sec	Specifies the fade-in time for the inset screen when recalling a memory that includes a PinP composite.														
PRIORITY	Specifies whether the preset memory values are applied to the knobs when recalling a preset memory.															
	<b>PANEL</b>	Keeps the existing values. The preset memory values are not applied to the knobs.														
	MEMORY	The values saved in the memory are applied. The positions of the faders and knobs might differ from the actual values.														
LOAD PARAMETER	Specifies whether to recall the following items when recalling a preset memory. Items that are turned off are excluded from the preset memories that are recalled.															
VIDEO INPUT	<b>OFF</b> , ON	VIDEO INPUT menu														
VIDEO OUTPUT	<b>OFF</b> , ON	VIDEO OUTPUT menu														
TRANSITION TIME	OFF, <b>ON</b>	TRANSITION TIME menu														
MIX/WIPE	OFF, <b>ON</b>	MIX/WIPE menu														
SPLIT	OFF, <b>ON</b>	SPLIT menu														
PinP	OFF, <b>ON</b>	PinP menu														
DSK	OFF, <b>ON</b>	DSK menu														

Menu item	Value (bold text: default value)	Explanation
VIDEO CROSSPOINT	OFF, <b>ON</b>	Cross-point button state
STILL IMAGE OUTPUT	OFF, <b>ON</b>	Still image output (the states of buttons [1/5]–[4/8] when the [MODE] button is lit red)
AUDIO INPUT	OFF, <b>ON</b>	AUDIO INPUT menu
AUDIO OUTPUT	OFF, <b>ON</b>	AUDIO OUTPUT menu
AUDIO FOLLOW	OFF, <b>ON</b>	AUDIO FOLLOW menu

## 12: CAPTURE IMAGE

Menu item	Value (bold text: default value)	Explanation						
LOAD FROM USB MEMORY	<b>STILL 1–4</b>	<p>Specifies where to save still images imported from a USB flash drive to this unit's internal memory. Press the [VALUE] knob to load the still images.</p> <p>* An internal memory in which a still image is loaded is indicated by a “* ” symbol.</p> <p><b>Formats supported for loading</b></p> <table border="1"> <tbody> <tr> <td><b>Format</b></td> <td>Windows Bitmap file (.bmp), 24-bit color, uncompressed PNG file (.png), 24-bit color * Alpha channel is not supported.</td> </tr> <tr> <td><b>Resolution</b></td> <td>Maximum 1920 x 1080 pixels</td> </tr> <tr> <td><b>File name</b></td> <td>No more than 28 single-byte alphanumeric characters * The extension “.bmp” or “.png” must be added.</td> </tr> </tbody> </table>	<b>Format</b>	Windows Bitmap file (.bmp), 24-bit color, uncompressed PNG file (.png), 24-bit color * Alpha channel is not supported.	<b>Resolution</b>	Maximum 1920 x 1080 pixels	<b>File name</b>	No more than 28 single-byte alphanumeric characters * The extension “.bmp” or “.png” must be added.
<b>Format</b>	Windows Bitmap file (.bmp), 24-bit color, uncompressed PNG file (.png), 24-bit color * Alpha channel is not supported.							
<b>Resolution</b>	Maximum 1920 x 1080 pixels							
<b>File name</b>	No more than 28 single-byte alphanumeric characters * The extension “.bmp” or “.png” must be added.							
DELETE STILL IMAGE	<b>STILL 1–4</b>	<p>Selects the still images to delete. Press the [VALUE] knob to delete the still images.</p> <p>* An internal memory in which a still image is loaded is indicated by a “* ” symbol.</p>						
CAPTURE IMAGE	ENTER	<p>Displays the CAPTURE IMAGE screen. Follow the instructions on the screen, capture a still image from the input video.</p>						

## 13: FREEZE

Menu item	Value (bold text: default value)	Explanation
FREEZE	<b>OFF</b> , ON	Turns the freeze function on/off. If this is “ON,” the input video is temporarily frozen.
TYPE	Specifies the operation mode for freezes.	
	<b>ALL</b>	Freezes all video that is being input.
	SELECT	Freezes only the specified input video.
INPUT 1–4 (*16)	DISABLE, <b>ENABLE</b>	For each input, specifies whether the freeze function is enabled (ENABLE) or disabled (DISABLE).

(\*16) This can be set if “TYPE” is “SELECT.”



## 14: AUTO SWITCHING

Menu item	Value (bold text: default value)	Explanation
AUTO SWITCHING	<b>OFF</b> , ON	Turns the auto switching function on/off. If this is "ON," the video or preset memory are switched automatically.
TYPE	Specifies the operation mode for auto switching.	
	<b>INPUT SCAN</b>	Automatically switches to the video of INPUT 1–4 when the specified interval.
	PRESET MEMORY SCAN	Automatically recalls preset memories 1–8 at the specified interval. The video and audio are switched according to the settings that are saved in each preset memory.
	BPM SYNC	Synchronizes the PGM/A bus and PST/B bus video, so that they switch automatically in sync with the BPM (number of beats per minute) you set.
When TYPE = INPUT SCAN		
SCAN SEQUENCE	Specifies the order in which video signals are shown. * If there is no video input, this is skipped.	
	<b>NORMAL</b>	Switches in the order of INPUT 1 → 4.
	REVERSE	Switches in the order of INPUT 4 → 1.
	RANDOM	Switches randomly.
SCAN TRANSITION TIME	0.0– <b>1.0</b> –4.0sec	Specifies the video transition time.
INPUT 1–4 TIME	OFF, 1– <b>5</b> –120sec	Specifies the time that the video is shown. Turn this "OFF" to skip.
When TYPE = PRESET MEMORY SCAN		
SCAN SEQUENCE	Specifies the order in which preset memories are switched. * Preset memories in which no settings have been saved are skipped.	
	<b>NORMAL</b>	Switches in the order of preset memory 1 → 8.
	REVERSE	Switches in the order of preset memory 8 → 1.
	RANDOM	Switches randomly.
MEMORY 1–8 TIME	OFF, 1– <b>5</b> –120sec	Specifies the time it takes to switch to the next preset memory. Turn this "OFF" to skip.
When TYPE = BPM SYNC		
BPM	20– <b>120</b> –250	Specifies the BPM (number of beats per minute). If the "BPM TAP" function is assigned to the [DSK PVW] or the [DSK ON] button, you can set the BPM according to the tempo at which you press the button. The button flashes in sync with the current BPM setting.
MODE	Specifies how the video is switched.	
	<b>TRANSITION</b>	The video switches using the currently selected transition effect (mix or wipe).
	CUT	The video switches as a cut.
SPEED	x1/4, x1/2, <b>x1</b> , x2	Specifies the video switching speed as a multiple of the specified BPM.
TAP RESET	Specifies how the video switches while you edit the BPM with the [DSK PVW] or [DSK ON] buttons.	
	OFF	Changes to the BPM are applied while the video continues to switch.
	ON	Resets the switch and starts switching at the new BPM you entered.

## 15: USB MEMORY

Menu item	Value (bold text: default value)	Explanation
RESTORE ALL SETTINGS	ENTER	Shows a list of the setting files (.V1P) that are on the USB flash drive. You can select a setting file and restore the settings into the unit. The current settings are overwritten.
BACKUP ALL SETTINGS	ENTER	Shows a list of the setting files (.V1P) that are on the USB flash drive. You can select the settings file used to back up the current settings to the USB flash drive. When you select an existing file, the file is overwritten. To save the settings as a new file, select "NEW FILE..."  <b>Content that is not saved to the file</b> <ul style="list-style-type: none"> <li>The SYSTEM menu settings "TEST PATTERN" and "TEST TONE." The unit always starts with these "OFF."</li> <li>The FREEZE menu settings "FREEZE." The unit always starts with these "OFF."</li> <li>The state of the [DSK PVW] and [DSK ON] buttons, to which the "STILL 1–4 OUTPUT" and "REC START/STOP" functions have been assigned. These buttons are always dark when the unit starts up.</li> <li>The state of the [OUTPUT FADE] knob.</li> <li>The still images loaded into the unit.</li> </ul>
FORMAT	EXEC	Formats the USB flash drive.

## 16: TALLY/RS-232

Menu item	Value (bold text: default value)	Explanation
TALLY	OFF, <b>ON</b>	Turns the tally signal output on/off. If this is "ON," the tally signal is output from the TALLY connector (p. 67).
RS-232	OFF, <b>ON</b>	If this is "ON," RS-232 commands can be transmitted and received.
RATE	38400, <b>115200</b>	Specifies the communication speed (bps) of the RS-232 connector.

## 17: SYSTEM

Menu item	Value (bold text: default value)	Explanation	
HDCP (*17)	<b>OFF</b> , ON	Specifies whether HDCP is enabled or disabled. If this is "ON," copyright-protected (HDCP) video can be input. HDCP is also added to the video that is output.	
FRAME RATE (*17)	59.94, 50Hz	Specifies the frame rate.	
SYSTEM FORMAT (*17)	<b>1080p</b> , 1080i, 720p	Specifies the system format. * The output format is the same as the system format.	
CUT SW ASSIGN (*18)	Specifies the function of the [CUT] button.		
	▲AUTO TAKE	When the video of the B/PST bus is selected, switches to the video of the A/PGM bus. The transition time is specified by the TRANSITION TIME menu item "WIPE/MIX TIME."	
	▲AUTO TAKE▼	Switches the video between A/PGM bus and B/PST bus. The transition time is specified by the TRANSITION TIME menu item "WIPE/MIX TIME."	
	▲CUT	When the video of the B/PST bus is selected, switches to the video of the A/PGM bus as a cut.	
	▲CUT▼	Switches the video between A/PGM bus and B/PST bus as a cut.	
AUTO SW ASSIGN (*18)	Specifies the function of the [AUTO] button.		
	AUTO TAKE▼	When the video of the A/PGM bus is selected, switches to the video of the B/PST bus. The transition time is specified by the TRANSITION TIME menu item "WIPE/MIX TIME."	
	▲AUTO TAKE▼	Switches the video between A/PGM bus and B/PST bus. The transition time is specified by the TRANSITION TIME menu item "WIPE/MIX TIME."	
	CUT▼	When the video of the A/PGM bus is selected, switches to the video of the B/PST bus as a cut.	
	▲CUT▼	Switches the video between A/PGM bus and B/PST bus as a cut.	
PANEL OPERATION	Specifies the operation mode for video transitions.		
	A/B	The video of the bus toward which the video fader is slid becomes the final output.	
	PGM/PST	The video on the A/PGM bus is always the final output. Select the preview output video (the video to be output next) for the B/PST bus side.	
PANEL LOCK	ENTER	Displays the PANEL LOCK menu.	
	Enable (ON) or disable (OFF) the panel lock.		
	Menu item	Value (bold text: default value)	Explanation
	ALL SW & VOLUME	<b>OFF</b> , ON	The following settings are turned on/off together.
	A/PGM 1-4 SW	<b>OFF</b> , ON	A/PGM cross-point [1]-[4] buttons
	B/PST 1-4 SW	<b>OFF</b> , ON	B/PST cross-point [1]-[4] buttons
	CUT SW	<b>OFF</b> , ON	[CUT] button
	AUTO SW	<b>OFF</b> , ON	[AUTO] button
	1/5-4/8 SW	<b>OFF</b> , ON	[1/5]-[4/8] buttons
	MODE SW	<b>OFF</b> , ON	[MODE] button
	TRANSITION SW	<b>OFF</b> , ON	[TRANSITION] button
	VIDEO FADER	<b>OFF</b> , ON	Video fader
	PinP SW	<b>OFF</b> , ON	[PinP] button
	SPLIT SW	<b>OFF</b> , ON	[SPLIT] knob
	CONTROL KNOB	<b>OFF</b> , ON	[CONTROL 1] [CONTROL 2] knobs
	DSK PVW SW	<b>OFF</b> , ON	[DSK PVW] button
	DSK ON SW	<b>OFF</b> , ON	[DSK ON] button
	OUTPUT FADE	<b>OFF</b> , ON	[OUTPUT FADE] knob
	AUDIO LEVEL	<b>OFF</b> , ON	[AUDIO IN 1] [AUDIO IN 2] [LINE IN] [MAIN] knobs
	AUDIO GAIN	<b>OFF</b> , ON	[AUDIO GAIN 1] [AUDIO GAIN 2] knobs
SETUP (LINK) SW	<b>OFF</b> , ON	[SETUP] button	
LIMITER SW	<b>OFF</b> , ON	[LIMITER] button	

(\*17) A change in the setting is not applied until you press the [VALUE] knob to confirm.

(\*18) This can be set if "PANEL OPERATION" is "A/B."

Menu item	Value (bold text: default value)	Explanation															
CONTROL KNOB PRIORITY	Specifies the settings that are operated by the [CONTROL 1] and [CONTROL 2] knobs when both split and PinP compositing are on.																
	SPLIT	<table border="1"> <thead> <tr> <th>Knob</th> <th>SPLIT</th> <th>PinP</th> </tr> </thead> <tbody> <tr> <td>[CONTROL 1]</td> <td>A-CENTER</td> <td>POSITION H</td> </tr> <tr> <td>[CONTROL 2]</td> <td>B-CENTER</td> <td>POSITION V</td> </tr> <tr> <td>[CONTROL 3]</td> <td>CENTER POSITION</td> <td>SIZE</td> </tr> <tr> <td>[CONTROL 4]</td> <td>SPLIT TYPE</td> <td>ZOOM</td> </tr> </tbody> </table>	Knob	SPLIT	PinP	[CONTROL 1]	A-CENTER	POSITION H	[CONTROL 2]	B-CENTER	POSITION V	[CONTROL 3]	CENTER POSITION	SIZE	[CONTROL 4]	SPLIT TYPE	ZOOM
	Knob	SPLIT	PinP														
[CONTROL 1]	A-CENTER	POSITION H															
[CONTROL 2]	B-CENTER	POSITION V															
[CONTROL 3]	CENTER POSITION	SIZE															
[CONTROL 4]	SPLIT TYPE	ZOOM															
PinP	* If you turn a knob while pressing it, these knobs function as [CONTROL 3] [CONTROL 4] knobs.																
OUTPUT FADE ASSIGN	Specify the functions when turning the [OUTPUT FADE] knob counter-clockwise (TURN LEFT) or clockwise (TURN RIGHT).																
TURN LEFT TURN RIGHT	BLACK	The final output video is faded-in/out to a black screen.															
	WHITE	The final output video is faded-in/out to a white screen.															
	AUDIO	Adjusts the output volume.															
	<b>BLACK&amp;AUDIO</b>	Fades-in/out the final output video and audio simultaneously. The video fades to a black screen. This is the default setting for "TURN LEFT."															
	<b>WHITE&amp;AUDIO</b>	Fades-in/out the final output video and audio simultaneously. The video fades to a white screen. This is the default setting for "TURN RIGHT."															
	<b>STILL 1-4 OUTPUT</b>	The specified still image is output as a cut to final/preview output.															
DSK PVW SW ASSIGN DSK ON SW ASSIGN	Specifies the function of the [DSK PVW] [DSK ON] buttons.																
	N/A	No function is assigned.															
	<b>DSK SW</b>	Turns DSK composition on/off. This is the default setting for "DSK ON SW ASSIGN."															
	<b>DSK PVW</b>	Turns the preview output of the DSK compositing result on/off. This is the default setting for "DSK PVW SW ASSIGN."															
	FREEZE	Turns the freeze function on/off.															
	AUTO SWITCHING	Turns the auto switching function on/off.															
	INPUT 1-4 ASSIGN	When "TYPE" in the AUTO SWITCHING menu is "BPM SYNC," you can set the BPM according to the tempo at which you press the button. The buttons flash in sync with the current BPM setting.															
	INPUT 1-4 ASSIGN	The video source assigned to the specified input switches between HDMI and STILL 1 through 4 in order, with each press of the button. * If there is no video input or if a still image has not been saved, this is skipped.															
	STILL 1-4 OUTPUT	Outputs the specified still image.															
	INPUT 1-4 MUTE	Turns the mute function on/off for the specified input audio.															
	AUDIO IN 1, 2 MUTE																
	LINE IN MUTE																
	MIC/AUXIN MUTE																
	OUTPUT MUTE	Turns on/off the mute function for the output audio.															
	REVERB SW	Turns reverb on/off.															
	INPUT SCAN N	The final output switches from INPUT 1 → 4 in order, with each press of the button. * If there is no video input, this is skipped.															
	INPUT SCAN R	The final output switches from INPUT 4 → 1 in order, with each press of the button. * If there is no video input, this is skipped.															
	MEMORY SCAN N	The preset memories 1 → 8 are recalled in order with each press of the button. * Preset memories in which no settings have been saved are skipped.															
	MEMORY SCAN R	The preset memories 8 → 1 are recalled in order with each press of the button. * Preset memories in which no settings have been saved are skipped.															
	REC START/STOP	Controls the recorder's video record start/stop if a recorder that supports REC control functionality is connected.															
LED DIMMER	1-8	Adjusts the brightness when the buttons or indicators are lit.															
ON SCREEN MENU	<b>UPPER LEFT</b> , UPPER RIGHT, LOWER LEFT, LOWER RIGHT	Specifies the location of the menu displayed on the multi-view.															
TALLY FRAME	OFF, <b>ON</b>	Specifies whether to display the tally frame or not in the multi-view.															
STILL/PinP INDICATOR	OFF, <b>ON</b>	If this is "ON," the indicators display the status in the still image or input video section of multi-view, as shown below.															
		<table border="1"> <thead> <tr> <th>Color</th> <th>Explanation</th> </tr> </thead> <tbody> <tr> <td>Yellow</td> <td>Shows that this has been selected as an inset screen for the PinP.</td> </tr> <tr> <td>Red</td> <td>Shows whether the still image has been output. * Only when pressing the [1/5]-[4/8] buttons and outputting a still image (p. 22).</td> </tr> </tbody> </table>	Color	Explanation	Yellow	Shows that this has been selected as an inset screen for the PinP.	Red	Shows whether the still image has been output. * Only when pressing the [1/5]-[4/8] buttons and outputting a still image (p. 22).									
Color	Explanation																
Yellow	Shows that this has been selected as an inset screen for the PinP.																
Red	Shows whether the still image has been output. * Only when pressing the [1/5]-[4/8] buttons and outputting a still image (p. 22).																
REC INDICATOR	OFF, <b>ON</b>	Specifies whether to display the REC indicator in the multi-view. When this is "ON," a REC indicator showing that the camera's REC button has been pressed is displayed, if the unit is connected to a camera that supports the REC status function.															

## Menu List

Menu item	Value (bold text: default value)	Explanation																																												
AUDIO LEVEL METER	OFF, <b>ON</b>	Specifies whether to display the audio level meter in the multi-view.																																												
AUDIO IN/LINE IN	OFF, LOWER, <b>UPPER</b>	Specifies the position of the level meter for audio input from the audio jacks. When this is "OFF," the level meter is always hidden.																																												
MULTI-VIEW LABEL	OFF, <b>ON</b>	Specifies whether to display the label in the multi-view.																																												
MULTI-VIEW LABEL EDIT	<b>HDMI 1-4</b> , STILL 1-4	Edit the label name shown in the multi-view. Press the [VALUE] knob to access the LABEL EDIT screen.																																												
MULTI-VIEW LAYOUT	Specifies the screen layout of the PVW section and PGM section shown in the multi-view. <table border="1" style="width: 100%; border-collapse: collapse;"> <thead> <tr> <th style="text-align: left;">PVW.PGM</th> <th style="text-align: left;">PGM.PVW</th> <th style="text-align: left;">BLACK.PGM</th> <th style="text-align: left;">PGM.BLACK</th> </tr> </thead> <tbody> <tr> <td style="text-align: center;"> <table border="1" style="display: inline-table; border-collapse: collapse;"> <tr><td style="background-color: #ADD8E6;">PVW</td><td style="background-color: #ADD8E6;">PGM</td></tr> <tr><td> </td><td> </td></tr> <tr><td> </td><td> </td></tr> <tr><td> </td><td> </td></tr> </table> </td> <td style="text-align: center;"> <table border="1" style="display: inline-table; border-collapse: collapse;"> <tr><td style="background-color: #ADD8E6;">PGM</td><td style="background-color: #ADD8E6;">PVW</td></tr> <tr><td> </td><td> </td></tr> <tr><td> </td><td> </td></tr> <tr><td> </td><td> </td></tr> </table> </td> <td style="text-align: center;"> <table border="1" style="display: inline-table; border-collapse: collapse;"> <tr><td style="background-color: black;"> </td><td style="background-color: #ADD8E6;">PGM</td></tr> <tr><td> </td><td> </td></tr> <tr><td> </td><td> </td></tr> <tr><td> </td><td> </td></tr> </table> </td> <td style="text-align: center;"> <table border="1" style="display: inline-table; border-collapse: collapse;"> <tr><td style="background-color: #ADD8E6;">PGM</td><td style="background-color: black;"> </td></tr> <tr><td> </td><td> </td></tr> <tr><td> </td><td> </td></tr> <tr><td> </td><td> </td></tr> </table> </td> </tr> <tr> <td></td> <td style="text-align: center;">The PVW section is not shown.</td> <td style="text-align: center;">The PVW section is not shown.</td> <td></td> </tr> </tbody> </table>		PVW.PGM	PGM.PVW	BLACK.PGM	PGM.BLACK	<table border="1" style="display: inline-table; border-collapse: collapse;"> <tr><td style="background-color: #ADD8E6;">PVW</td><td style="background-color: #ADD8E6;">PGM</td></tr> <tr><td> </td><td> </td></tr> <tr><td> </td><td> </td></tr> <tr><td> </td><td> </td></tr> </table>	PVW	PGM							<table border="1" style="display: inline-table; border-collapse: collapse;"> <tr><td style="background-color: #ADD8E6;">PGM</td><td style="background-color: #ADD8E6;">PVW</td></tr> <tr><td> </td><td> </td></tr> <tr><td> </td><td> </td></tr> <tr><td> </td><td> </td></tr> </table>	PGM	PVW							<table border="1" style="display: inline-table; border-collapse: collapse;"> <tr><td style="background-color: black;"> </td><td style="background-color: #ADD8E6;">PGM</td></tr> <tr><td> </td><td> </td></tr> <tr><td> </td><td> </td></tr> <tr><td> </td><td> </td></tr> </table>		PGM							<table border="1" style="display: inline-table; border-collapse: collapse;"> <tr><td style="background-color: #ADD8E6;">PGM</td><td style="background-color: black;"> </td></tr> <tr><td> </td><td> </td></tr> <tr><td> </td><td> </td></tr> <tr><td> </td><td> </td></tr> </table>	PGM									The PVW section is not shown.	The PVW section is not shown.	
PVW.PGM	PGM.PVW	BLACK.PGM	PGM.BLACK																																											
<table border="1" style="display: inline-table; border-collapse: collapse;"> <tr><td style="background-color: #ADD8E6;">PVW</td><td style="background-color: #ADD8E6;">PGM</td></tr> <tr><td> </td><td> </td></tr> <tr><td> </td><td> </td></tr> <tr><td> </td><td> </td></tr> </table>	PVW	PGM							<table border="1" style="display: inline-table; border-collapse: collapse;"> <tr><td style="background-color: #ADD8E6;">PGM</td><td style="background-color: #ADD8E6;">PVW</td></tr> <tr><td> </td><td> </td></tr> <tr><td> </td><td> </td></tr> <tr><td> </td><td> </td></tr> </table>	PGM	PVW							<table border="1" style="display: inline-table; border-collapse: collapse;"> <tr><td style="background-color: black;"> </td><td style="background-color: #ADD8E6;">PGM</td></tr> <tr><td> </td><td> </td></tr> <tr><td> </td><td> </td></tr> <tr><td> </td><td> </td></tr> </table>		PGM							<table border="1" style="display: inline-table; border-collapse: collapse;"> <tr><td style="background-color: #ADD8E6;">PGM</td><td style="background-color: black;"> </td></tr> <tr><td> </td><td> </td></tr> <tr><td> </td><td> </td></tr> <tr><td> </td><td> </td></tr> </table>	PGM																		
PVW	PGM																																													
PGM	PVW																																													
	PGM																																													
PGM																																														
	The PVW section is not shown.	The PVW section is not shown.																																												
OUTPUT 2 OSD	ENTER	Displays the OUTPUT 2 OSD menu.																																												
	Specifies what is displayed for multi-view output sent through the OUTPUT 2 connector.																																													
	<table border="1" style="width: 100%; border-collapse: collapse;"> <thead> <tr> <th style="text-align: left;">Menu item</th> <th style="text-align: left;">Value (bold text: default value)</th> <th style="text-align: left;">Explanation</th> </tr> </thead> <tbody> <tr> <td>TALLY FRAME</td> <td>OFF, <b>ON</b></td> <td>Specifies whether to display the tally frame or not in the multi-view.</td> </tr> <tr> <td>LABEL/LEVEL METER/MARK</td> <td>OFF, <b>ON</b></td> <td>Specifies whether to display the label, audio level meter and REC indicator in the multi-view.</td> </tr> </tbody> </table>	Menu item	Value (bold text: default value)	Explanation	TALLY FRAME	OFF, <b>ON</b>	Specifies whether to display the tally frame or not in the multi-view.	LABEL/LEVEL METER/MARK	OFF, <b>ON</b>	Specifies whether to display the label, audio level meter and REC indicator in the multi-view.																																				
Menu item	Value (bold text: default value)	Explanation																																												
TALLY FRAME	OFF, <b>ON</b>	Specifies whether to display the tally frame or not in the multi-view.																																												
LABEL/LEVEL METER/MARK	OFF, <b>ON</b>	Specifies whether to display the label, audio level meter and REC indicator in the multi-view.																																												
AUTO INPUT DETECT	<b>OFF</b> , ON	Turns the auto input detect function on/off. If this is "ON," input is automatically detected, and the video is switched when input from the final output video is interrupted.																																												
AUTO OFF	OFF, <b>ON</b>	Turns the Auto Off function on/off. If this is "ON," the power to the unit turns off automatically when all of the following states persist for 240 minutes. <ul style="list-style-type: none"> <li>No operation performed on the unit</li> <li>No audio or video input</li> <li>No equipment is connected to the OUTPUT 1 and 2 connectors</li> </ul>																																												
TEST PATTERN	<b>OFF</b> , 75% COLOR BAR, 100% COLOR BAR, RAMP, STEP, HATCH	Specifies the test pattern.																																												
TEST TONE	OFF, -20dB@1kHz, -10dB@1kHz, 0dB@1kHz, 20dB@1kHz:500Hz, -10dB@1kHz:500Hz, 0dB@1kHz:500Hz	Specifies the test tone.																																												
VIDEO FADER CALIBRATE	ENTER	Displays the VIDEO FADER SET screen. Following the instructions on the screen, calibrate (adjust) the video fader. In some cases, because of continued use or transport, the video output might not reach 100% even if you slide the video fader all the way to the left or right. Execute video fader calibration in this case as well.																																												
FACTORY RESET	EXEC	Returns the unit to its factory defaults.																																												
VERSION	—	Displays the version of the system program.																																												

# RS-232 Command Reference

This unit supports remote interface communications via RS-232. Using the RS-232 connector to send specific commands to this unit from a controlling device lets you operate this unit remotely.

\* To send and receive RS-232 commands, press the [MENU] button, and from "TALLY/RS-232," set "RS-232" to "ON."

## RS-232 Interface

### RS-232 connector pin layout

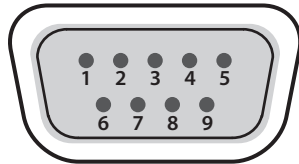

DB-9 type (male)

### Pin assignments

Pin No.	Signal name
1	N.C.
2	RXD
3	TXD
4	DTR
5	GND
6	DSR
7	RTS
8	CTS
9	N.C.

### Communication standards

Communication method	Synchronous (asynchronous), full-duplex
Communication speed	38,400/115,200 bps
Parity	none
Data length	8 bits
Stop bit	1 bit
Code set	ASCII
Flow control	XON/XOFF

### Cable wiring diagram

Use an RS-232 crossover cable to connect this unit and the controller (an RS-232-compatible computer or other device).

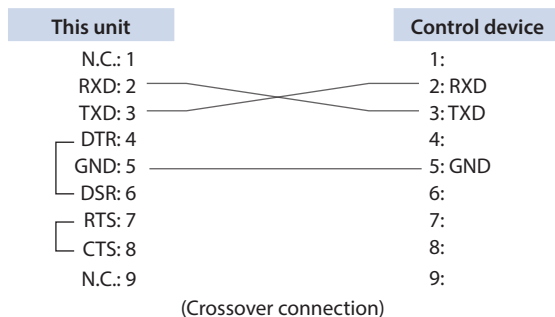

\* The connections between 4 and 6 and between 7 and 8 are inside this unit.

## Command Format

Commands are formatted using the configuration shown below. Commands are all in ASCII code.

```
stx Command code : Parameter , Parameter ;
```

stx	ASCII code "02H" is a control code indicating the start of a command. "H" indicates that it is a hexadecimal value.
Command code	This specifies the command type (three single-byte alphanumeric characters).
Parameter	This is appended to a command that requires one or more parameter. The command and the parameter portion are separated by a ":" (colon). When there are multiple parameters, they are each separated by "," (comma) characters.
;	This is the code that this unit recognizes as the end of a command.

\* The codes of stx (02H), ack (06H), and XON (11H)/ XOFF (13H) are the control codes.

## List of Commands

\* When sending a sequence of commands to this unit from a controller, after each one, be sure to verify that an “ack” response is returned before sending the next command.

### Video operations

Item	Sent command	Response command	Parameter	
Select video source for INPUT 1–4	stxIPS:a,b;	ack	a = 0 (INPUT 1), 1 (INPUT 2), 2 (INPUT 3), 3 (INPUT 4) b = 0 (HDMI), 1 (STILL 1), 2 (STILL 2), 3 (STILL 3), 4 (STILL 4)	
Select video output from the OUTPUT 1 connector	stxOH1:a;	ack	a = 0 (PGM), 1 (PVW), 2 (Multi-View)	
Select video output from the OUTPUT 2 connector	stxOH2:a;	ack	a = 0 (PGM), 1 (PVW), 2 (Multi-View)	
Select final output video	stxPGM:a;	ack	a = 0 (INPUT 1), 1 (INPUT 2), 2 (INPUT 3), 3 (INPUT 4)	
Select preview output video	stxPST:a;	ack	a = 0 (INPUT 1), 1 (INPUT 2), 2 (INPUT 3), 3 (INPUT 4)	
Select transition effect	stxTRS:a;	ack	a = 0 (MIX), 1 (WIPE)	
Set video transition time	stxTIM:a;	ack	a = 0 (0.0 sec)–40 (4.0 sec)	
Press the [CUT] button	stxCUT;	ack		
Press the [AUTO] button	stxATO;	ack		
Press the [PinP] button	stxP1S;	ack		
Press the [SPLIT] button	stxSPS;	ack		
Press the [DSK ON] button	stxDSK;	ack		
Press the [DSK PVW] button	stxDVW;	ack		
PinP Adjust position of inset screen	stxPP1:a,b;	ack	a = -500–500 Horizontal position b = -500–500 Vertical position	
	Adjust size of the inset screen.	stxPPS:a;	ack	a = 100 (10.0%)–1000 (100.0%)
	Adjust zoom ratio of inset screen video	stxPPZ:a;	ack	a = 100 (100.0%)–400 (400.0%)
	Set the fade-in/out time for the inset screen	stxPTM:a;	ack	a = 0 (0.0 sec)–40 (4.0 sec)
Split Adjust position of the video	stxSPT:a,b;	ack	<b>When the split composition type is “SPLIT V”</b> Adjusts the position in the horizontal direction. a = -500–500 video on the left (Video on the A/PGM bus) b = -500–500 video on the right (Video on the B/PST bus)	
			<b>When the split composition type is “SPLIT H”</b> Adjusts the position in the vertical direction. a = -500–500 upper video (Video on the A/PGM bus) b = -500–500 lower video (Video on the B/PST bus)	
DSK Adjust the key level (amount of extraction)	stxSCP:a;	ack	a = -500–500	
	Adjust the key gain (semi-transmissive region)	stxKYL:a;	ack	a = 0–255
	Adjust the key gain (semi-transmissive region)	stxKYG:a;	ack	a = 0–255
Set the fade-in/out time for the source video	stxPTM:a;	ack	a = 0 (0.0 sec)–40 (4.0 sec)	
Turn the [OUTPUT FADE] knob	stxOFD:a;	ack	a = -63–64	

## Audio operations

Item	Sent command	Response command	Parameter
Adjust the input volume level	stxIAL:a,b;	ack	a = 0 (INPUT 1), 1 (INPUT 2), 2 (INPUT 3), 3 (INPUT 4), 4 (AUDIO IN 1) 5 (AUDIO IN 2), 6 (LINE IN), 7 (MIC/AUX IN) b = -801 (-INF dB), -800 (-80.0 dB)–0 (0.0 dB)–100 (10.0 dB)
Adjust the output volume level	stxOAL:a;	ack	a = -801 (-INF dB), -800 (-80.0 dB)–0 (0.0 dB)–100 (10.0 dB)
Adjust the analog gain for AUDIO IN 1/2, MIC/AUX IN	stxIAG:a,b;	ack	a = 0 (INPUT 1), 1 (INPUT 2), 2 (MIC/AUX IN) b = 0 (0 dB)–64 (64 dB) When a = 0 or 1 b = 0 (0 dB)–55 (55 dB) When a = 2
Adjust delay time of input audio	stxADT:a,b;	ack	a = 0 (INPUT 1), 1 (INPUT 2), 2 (INPUT 3), 3 (INPUT 4), 4 (AUDIO IN 1) 5 (AUDIO IN 2), 6 (LINE IN), 7 (MIC/AUX IN) b = 0 (0.0 ms)–5000 (5000.0 ms)
Press the [LIMITER] button	stxLIM;	ack	
Long-press the [SETUP] button (stereo link function on/off)	stxLNK;	ack	
Acquire information on volume level	stxQAL:a;	stxQAL:b;	<b>Send command parameters</b> a = 0 (INPUT 1), 1 (INPUT 2), 2 (INPUT 3), 3 (INPUT 4), 4 (AUDIO IN 1) 5 (AUDIO IN 2), 6 (LINE IN), 7 (MIC/AUX IN), 8 (ALL) <b>Response command parameters</b> a = 0, b = -801–100 INPUT 1 a = 1, b = -801–100 INPUT 2 a = 2, b = -801–100 INPUT 3 a = 3, b = -801–100 INPUT 4 a = 4, b = -801–100 AUDIO IN 1 a = 5, b = -801–100 AUDIO IN 2 a = 6, b = -801–100 LINE IN a = 7, b = -801–100 MIC/AUX IN a = 7, b = returns all volume levels described above. (Example) stxQAL:100,80,70,60,50,40,30,20; * b = -801 (-INF dB), -800 (-80.0 dB)–0 (0.0 dB)–100 (10.0 dB)
Specify the mute function for input audio	stxIAM:a, b;	ack	a = 0 (INPUT 1), 1 (INPUT 2), 2 (INPUT 3), 3 (INPUT 4), 4 (AUDIO IN 1), 5 (AUDIO IN 2), 6 (LINE IN), 7 (MIC/AUX IN) b = 0 (MUTE OFF), 1 (MUTE ON)
Specify the solo function for input audio	stxIAS:a, b;	ack	a = 0 (INPUT 1), 1 (INPUT 2), 2 (INPUT 3), 3 (INPUT 4), 4 (AUDIO IN 1) 5 (AUDIO IN 2), 6 (LINE IN), 7 (MIC/AUX IN) b = 0 (SOLO OFF), 1 (SOLO ON)

Other operations

Item	Sent command	Response command	Parameter
Select functions for buttons [1/5]–[4/8]	stxMOD;a;	ack	a = 0 (STILL IMAGE), 1 (PinP SOURCE), 2 (MEMORY 1–4), 3 (MEMORY 5–8),
Press button [1/5]–[4/8]	stxMNS;a;	ack	a = 0 (1/5)–3 (4/8)
Set HDCP on/off	stxHCP;a;	ack	a = 0 (OFF), 1 (ON)
Recall preset memory	stxMEM;a;	ack	a = 0 (1), 1 (2), 2 (3), 3 (4), 4 (5), 5 (6), 6 (7), 7 (8)
Set the fade-in time for the inset screen when recalling a memory	stxPFT;a;	ack	a = 0 (0.0sec)–10 (1.0sec)
Set test pattern	stxTPT;a;	ack	a = 0 (OFF), 1 (75% COLOR BAR), 2 (100% COLOR BAR), 3 (RAMP), 4 (STEP) 5 (HATCH)
Set test tone	stxTTN;a;	ack	a = 0 (OFF), 1 (-20dB@1kHz: 1kHz), 2 (-10dB@1kHz: 1kHz), 3 (0dB@1kHz: 1kHz) 4 (-20dB@1kHz: 500Hz), 5 (-10dB@1kHz: 500Hz), 6 (0dB@1kHz: 500Hz)
Retrieve status of controls	stxQPL;a;	stxQPL:b;	<p><b>Send command parameters</b></p> <p>a = 0 (PGM/A), 1 (PST/B), 2 (MODE 1/5–4/8), 3 (MODE), 4 (TRANSITION), 5 (SPLIT) 6 (PinP), 7 (DSK PVW), 8 (DSK ON), 9 (LIMITER), 10 (LINK), 11 (Video fade level) 12 (ALL)</p> <p><b>Response command parameters</b></p> <p>a = 0, b = 0 (INPUT 1)–4 (INPUT 4) A/PGM cross-point buttons a = 1, b = 0 (INPUT 1)–4 (INPUT 4) PST/B cross-point buttons a = 2, b = 0 (1/5)–4 (4/8) [1/5]–[4/8] buttons a = 3, b = 0 (STILL IMAGE) [MODE] button 1 (PinP SOURCE) 2 (MEMORY 1–4) 3 (MEMORY 5–8) a = 4, b = 0 (MIX), 1 (WIPE) [TRANSITION] button a = 5, b = 0 (Off), 1 (On) [SPLIT] button a = 6, b = 0 (Off), 1 (On) [PinP] button a = 7, b = 0 (Off), 1 (On) Preview output of the DSK compositing result a = 8, b = 0 (Off), 1 (On) DSK composition a = 9, b = 0 (Off), 1 (On) [LIMITER] button a = 10, b = 0 (Off), 1 (On) [SETUP] button (stereo link function) a = 11, b = 0–2047 a = 12, b = returns all information described above. (Example) stxQPL:0,3,2,1,1,0,0,0,0,0;</p>
Retrieve output status of INPUT 1–4	stxTLY;	stxTLY:a,b,c,d;	a–d = 0 (Dark), 1 (Red: final output), 2 (Green: preview output) This returns the output status for INPUT 1–4. (Example) stxTLY:1,2,0,0;
Acquire status of the unit	stxACS;	ack	
Version information	stxVER;	VER:V-1HD PLUS;a;	a = Version number * The version info is ASCII text strings.
Flow control	XON		
Flow control	XOFF		

Commands spontaneously sent from this unit

Item	Sent command	Response command	Parameter
Error detected		stxERR;a;	a = 0 (Syntax error) The received command contains an error. 5 (Out of range error) A parameter of the received command is out of range.
Flow control		XON	
Flow control		XOFF	



# Appendices

## Main Specifications

Video																																																		
<b>Video Processing</b>	4:2:2 (Y/Pb/Pr), 8-bit																																																	
<b>Input Connectors</b>	INPUT 1-3	HDMI type A x 3 * HDCP supported																																																
	INPUT 4	HDMI type A * HDCP and multi-format supported																																																
<b>Output Connectors</b>	OUTPUT 1, 2	HDMI type A x 2																																																
<b>Input formats</b>	INPUT 1-3	<table border="1"> <thead> <tr> <th colspan="2">SYSTEM FORMAT setting: 720p</th> <th colspan="2">SYSTEM FORMAT setting: 1080i or 1080p</th> </tr> <tr> <th colspan="2">FRAME RATE setting</th> <th colspan="2">FRAME RATE setting</th> </tr> <tr> <th>59.94 Hz</th> <th>50 Hz</th> <th>59.94 Hz</th> <th>50 Hz</th> </tr> </thead> <tbody> <tr> <td>720/59.94p</td> <td>720/50p</td> <td>1080/59.94i</td> <td>1080/29.97p</td> </tr> <tr> <td>720/60p</td> <td></td> <td>1080/60i</td> <td>1080/30p</td> </tr> <tr> <td></td> <td></td> <td>1080/59.94p</td> <td>1080/23.98p</td> </tr> <tr> <td></td> <td></td> <td>1080/60p</td> <td>1080/24p</td> </tr> <tr> <td></td> <td></td> <td></td> <td>1080/50i</td> </tr> <tr> <td></td> <td></td> <td></td> <td>1080/50p</td> </tr> <tr> <td></td> <td></td> <td></td> <td>1080/25p</td> </tr> <tr> <td></td> <td></td> <td></td> <td>1080/23.98p</td> </tr> <tr> <td></td> <td></td> <td></td> <td>1080/24p</td> </tr> </tbody> </table> <p>* The input interlaced video signal is converted to progressive video signal by internal processing.</p>	SYSTEM FORMAT setting: 720p		SYSTEM FORMAT setting: 1080i or 1080p		FRAME RATE setting		FRAME RATE setting		59.94 Hz	50 Hz	59.94 Hz	50 Hz	720/59.94p	720/50p	1080/59.94i	1080/29.97p	720/60p		1080/60i	1080/30p			1080/59.94p	1080/23.98p			1080/60p	1080/24p				1080/50i				1080/50p				1080/25p				1080/23.98p				1080/24p
	SYSTEM FORMAT setting: 720p		SYSTEM FORMAT setting: 1080i or 1080p																																															
	FRAME RATE setting		FRAME RATE setting																																															
59.94 Hz	50 Hz	59.94 Hz	50 Hz																																															
720/59.94p	720/50p	1080/59.94i	1080/29.97p																																															
720/60p		1080/60i	1080/30p																																															
		1080/59.94p	1080/23.98p																																															
		1080/60p	1080/24p																																															
			1080/50i																																															
			1080/50p																																															
			1080/25p																																															
			1080/23.98p																																															
			1080/24p																																															
INPUT 4	<table border="1"> <thead> <tr> <th colspan="2">FRAME RATE setting</th> </tr> <tr> <th>59.94 Hz</th> <th>50 Hz</th> </tr> </thead> <tbody> <tr> <td>480/59.94i</td> <td>576/50i</td> </tr> <tr> <td>480/59.94p</td> <td>576/50p</td> </tr> <tr> <td>720/59.94p</td> <td>720/50p</td> </tr> <tr> <td>720/60p</td> <td>1080/50i</td> </tr> <tr> <td>1080/59.94i</td> <td>1080/29.97p</td> </tr> <tr> <td>1080/60i</td> <td>1080/30p</td> </tr> <tr> <td>1080/59.94p</td> <td>1080/23.98p</td> </tr> <tr> <td>1080/60p</td> <td>1080/24p</td> </tr> <tr> <td>VGA (640 x 480/60 Hz)</td> <td>VGA (640 x 480/60 Hz)</td> </tr> <tr> <td>SVGA (800 x 600/60 Hz)</td> <td>SVGA (800 x 600/60 Hz)</td> </tr> <tr> <td>XGA (1024 x 768/60 Hz)</td> <td>XGA (1024 x 768/60 Hz)</td> </tr> <tr> <td>WXGA (1280 x 800/60 Hz)</td> <td>WXGA (1280 x 800/60 Hz)</td> </tr> <tr> <td>SXGA (1280 x 1024/60 Hz)</td> <td>SXGA (1280 x 1024/60 Hz)</td> </tr> <tr> <td>FWXGA (1366 x 768/60 Hz)</td> <td>FWXGA (1366 x 768/60 Hz)</td> </tr> <tr> <td>SXGA+ (1400 x 1050/60 Hz)</td> <td>SXGA+ (1400 x 1050/60 Hz)</td> </tr> <tr> <td>UXGA (1600 x 1200/60 Hz)</td> <td>UXGA (1600 x 1200/60 Hz)</td> </tr> <tr> <td>WUXGA (1920 x 1200/60 Hz)</td> <td>WUXGA (1920 x 1200/60 Hz)</td> </tr> </tbody> </table> <p>* The refresh rate is the maximum value of each resolution.            * Conforms to CEA-861-E, VESA DMT Version 1.0 Revision 11.            * 1920 x 1200/60 Hz: Reduced blanking            * The input interlaced video signal is converted to progressive video signal by internal processing.</p>	FRAME RATE setting		59.94 Hz	50 Hz	480/59.94i	576/50i	480/59.94p	576/50p	720/59.94p	720/50p	720/60p	1080/50i	1080/59.94i	1080/29.97p	1080/60i	1080/30p	1080/59.94p	1080/23.98p	1080/60p	1080/24p	VGA (640 x 480/60 Hz)	VGA (640 x 480/60 Hz)	SVGA (800 x 600/60 Hz)	SVGA (800 x 600/60 Hz)	XGA (1024 x 768/60 Hz)	XGA (1024 x 768/60 Hz)	WXGA (1280 x 800/60 Hz)	WXGA (1280 x 800/60 Hz)	SXGA (1280 x 1024/60 Hz)	SXGA (1280 x 1024/60 Hz)	FWXGA (1366 x 768/60 Hz)	FWXGA (1366 x 768/60 Hz)	SXGA+ (1400 x 1050/60 Hz)	SXGA+ (1400 x 1050/60 Hz)	UXGA (1600 x 1200/60 Hz)	UXGA (1600 x 1200/60 Hz)	WUXGA (1920 x 1200/60 Hz)	WUXGA (1920 x 1200/60 Hz)											
FRAME RATE setting																																																		
59.94 Hz	50 Hz																																																	
480/59.94i	576/50i																																																	
480/59.94p	576/50p																																																	
720/59.94p	720/50p																																																	
720/60p	1080/50i																																																	
1080/59.94i	1080/29.97p																																																	
1080/60i	1080/30p																																																	
1080/59.94p	1080/23.98p																																																	
1080/60p	1080/24p																																																	
VGA (640 x 480/60 Hz)	VGA (640 x 480/60 Hz)																																																	
SVGA (800 x 600/60 Hz)	SVGA (800 x 600/60 Hz)																																																	
XGA (1024 x 768/60 Hz)	XGA (1024 x 768/60 Hz)																																																	
WXGA (1280 x 800/60 Hz)	WXGA (1280 x 800/60 Hz)																																																	
SXGA (1280 x 1024/60 Hz)	SXGA (1280 x 1024/60 Hz)																																																	
FWXGA (1366 x 768/60 Hz)	FWXGA (1366 x 768/60 Hz)																																																	
SXGA+ (1400 x 1050/60 Hz)	SXGA+ (1400 x 1050/60 Hz)																																																	
UXGA (1600 x 1200/60 Hz)	UXGA (1600 x 1200/60 Hz)																																																	
WUXGA (1920 x 1200/60 Hz)	WUXGA (1920 x 1200/60 Hz)																																																	
Still Image	Bitmap file (.bmp): Maximum 1920 x 1080 pixels, 24-bit color, uncompressed PNG file (.png): Maximum 1920 x 1080 pixels, 24-bit color * It can be stored up to 4 files in the internal memory. * PNG alpha channel not supported																																																	
<b>Output formats</b>	OUTPUT 1, 2	<table border="1"> <thead> <tr> <th rowspan="2">SYSTEM FORMAT setting</th> <th colspan="2">FRAME RATE setting</th> </tr> <tr> <th>59.94 Hz</th> <th>50 Hz</th> </tr> </thead> <tbody> <tr> <td>720p</td> <td>720/59.94p</td> <td>720/50p</td> </tr> <tr> <td>1080i</td> <td>1080/59.94i</td> <td>1080/50i</td> </tr> <tr> <td>1080p</td> <td>1080/59.94p</td> <td>1080/50p</td> </tr> </tbody> </table>	SYSTEM FORMAT setting	FRAME RATE setting		59.94 Hz	50 Hz	720p	720/59.94p	720/50p	1080i	1080/59.94i	1080/50i	1080p	1080/59.94p	1080/50p																																		
SYSTEM FORMAT setting	FRAME RATE setting																																																	
	59.94 Hz	50 Hz																																																
720p	720/59.94p	720/50p																																																
1080i	1080/59.94i	1080/50i																																																
1080p	1080/59.94p	1080/50p																																																
<b>Video Effects</b>	Transition	CUT, MIX (DISSOLVE/FAM/NAM), WIPE (8 types)																																																
	Composition	PinP (SQUARE, CIRCLE, DIAMOND), SPLIT (2 types), Keyer (Luminance key, Chroma key) DSK (Luminance key, Chroma key)																																																
	Other	Flip horizontal, Flip vertical, Still image capture, Still image playback Output fade (Audio, Video: WHITE or BLACK), Test pattern output																																																

■ Audio		
Sample rate	24 bits/48 kHz	
Audio formats	Linear PCM, 24 bits/48 kHz, 2 ch	
Input Connectors	INPUT 1-4	HDMI Type A x 4
	AUDIO IN 1-2	XLR-3-31 type (balanced, phantom power DC 48 V, 14 mA Max)
	LINE IN	RCA phono type
	MIC/AUX IN	Stereo miniature phone type (PLUG-IN power)
Output Connectors	OUTPUT 1-3	HDMI Type A x 2
	AUDIO OUT L, R	1/4-inch TRS phone type
	PHONES	Stereo miniature phone type
Nominal Input Level	AUDIO IN 1-2	-60 to +4 dBu (Maximum input level: +24 dBu)
	LINE IN	-10 dBu (Maximum input level: +10 dBu)
	MIC/AUX IN	-51 to -10 dBu (Maximum input level: +10 dBu)
Input Impedance	AUDIO IN 1-2	10 k $\Omega$
	LINE IN	15 k $\Omega$
	MIC/AUX IN	10 k $\Omega$
Nominal Output Level	AUDIO OUT L, R	+4 dBu (Maximum output level: +24 dBu)
	PHONES	72 mW + 72 mW (32 $\Omega$ load)
Output Impedance	AUDIO OUT L, R	600 $\Omega$
	PHONES	10 $\Omega$
Audio Effects	Delay, High pass filter, De-esser, Compressor, Noise gate, Equalizer, Limiter, Reverb, Test tone output	
■ Others		
Other Connectors	USB MEMORY	USB A type (for USB flash drive)
	USB	USB B type (for remote control)
	RS-232	DB-9 type (male, for remote control)
	TALLY	DB-9 type (female, for TALLY output)
Other Functions	Preset memory (8 types), Panel lock function, EDID emulator, Auto switching, Auto input detect	
Power Supply	AC Adaptor	
Current Draw	2.1 A	
Power Consumption	25.2 W	
Operation Temperature	+0 to +40 degrees Celsius	
	+32 to +104 degrees Fahrenheit	
Dimensions	316 (W) x 121 (D) x 65 (H) mm	
	12-1/2 (W) x 4-13/16 (D) x 2-9/16 (H) inches	
Weight (excluding AC adaptor)	1.4 kg	
	3 lbs 2 oz	
Accessories	Startup Guide, Leaflet "USING THE UNIT SAFELY," AC adaptor, Power cord	

\* 0 dBu = 0.775 Vrms

\* This document explains the specifications of the product at the time that the document was issued. For the latest information, refer to the Roland website.

## Dimensions

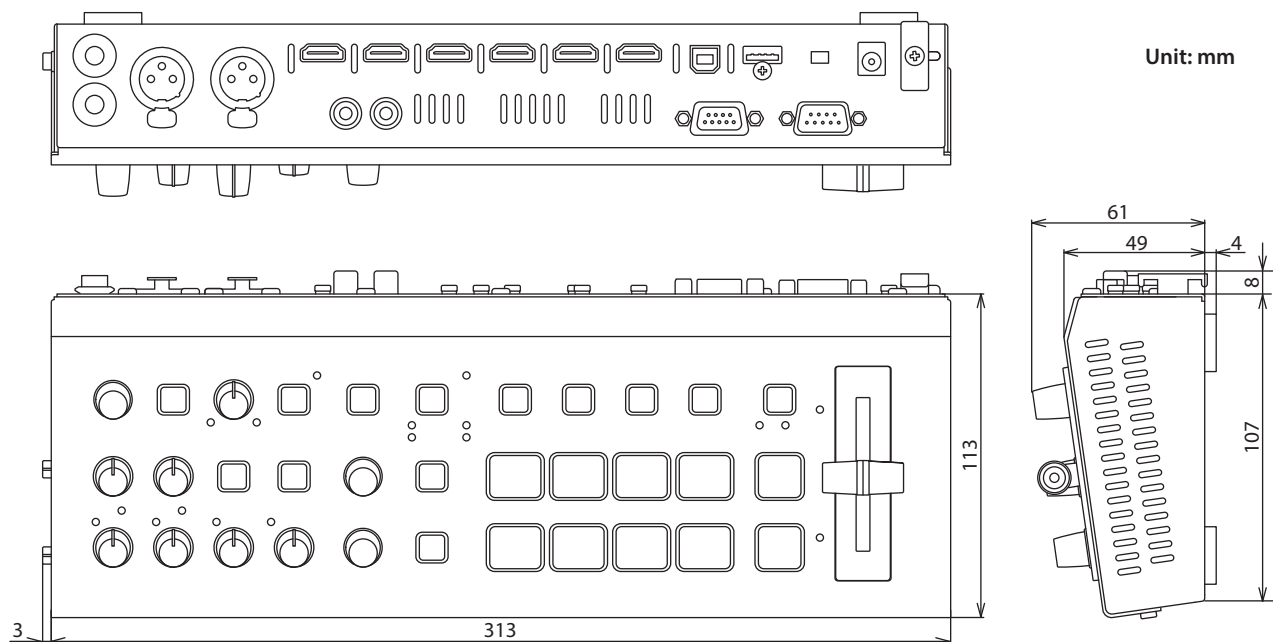

## Specification of the TALLY Connector

A tally signal can be output from the connector pin that supports final output video and preview output video.

\* To output the tally signal, press the [MENU] button, and from "TALLY/RS-232," set "TALLY" to "ON."

### TALLY connector pin layout

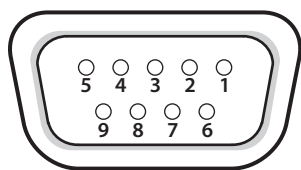

DB-9 type (female)

### Pin assignments

Pin No.	Target
1	GND
2	PGM/A cross-point [1] button
3	PGM/A cross-point [2] button
4	PGM/A cross-point [3] button
5	PGM/A cross-point [4] button
6	PST/B cross-point [1] button
7	PST/B cross-point [2] button
8	PST/B cross-point [3] button
9	PST/B cross-point [4] button

### Tally output

Trigger method	Open collector
Maximum input	12 V/200 mA

## Video Block Diagram

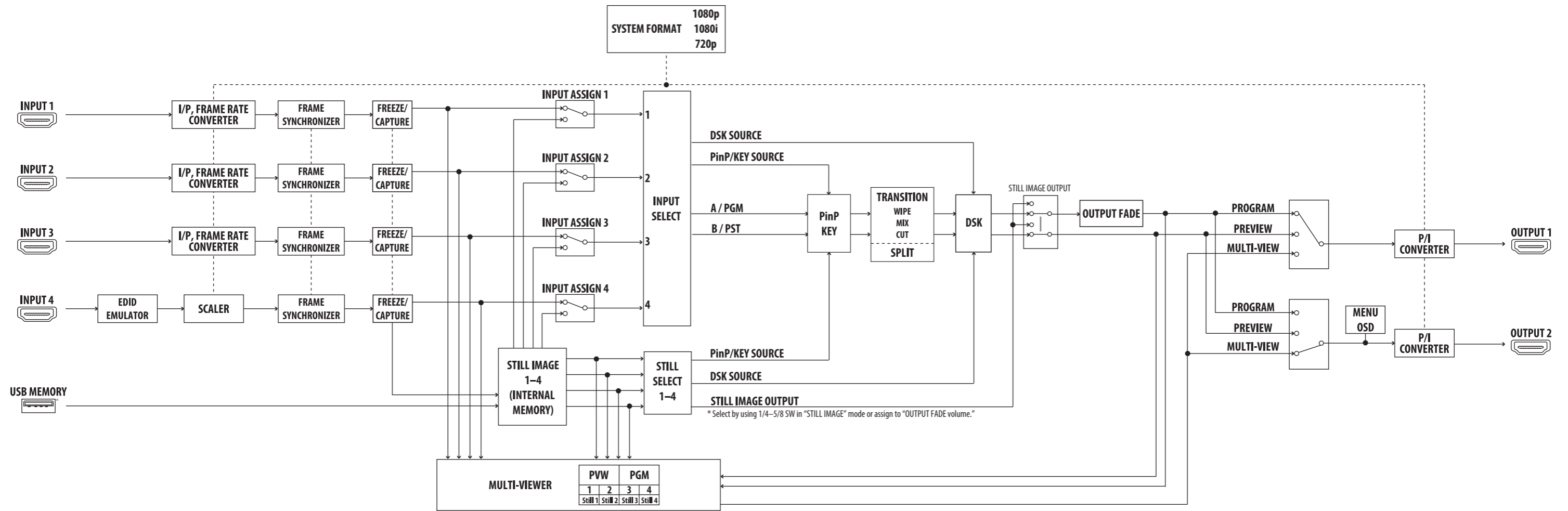

## Audio Block Diagram

