



PL200M



Speco Technologies
200 New Highway • Amityville, NY 11701
For more information on our products go to:
www.specotech.com or contact us at: 1-800-645-5516

www.specotech.com

IMPORTANT!

**Please read this manual carefully before operating
this unit for the first time.**

All rights reserved to Speco Technologies. All features and content might be changed without prior notice. Any photocopy, translation, or reproduction of part of this manual without written permission is forbidden.

SAFETY RELATED SYMBOLS



This symbol, wherever used, alerts you to the presence of un-insulated and dangerous voltages within the product enclosure. These are voltages that may be sufficient to constitute the risk of electric shock or death.



This symbol, wherever used, alerts you to important operating and maintenance instructions. Please read.



Protective Ground Terminal



AC mains (Alternating Current)



Hazardous Live Terminal

ON: Denotes the product is turned on.

OFF: Denotes the product is turned off.

WARNING

Describes precautions that should be observed to prevent the possibility of death or injury to the user.

CAUTION

Describes precautions that should be observed to prevent damage to the product.



Disposing of this product should not be placed in municipal waste and should be separate collection.

WARNING

• Power Supply

Ensure that the main voltage source (AC outlet) matches the voltage rating of the product. Failure to do so could result in damage to the product and possibly the user.

Unplug the product before electrical storms occur and when unused for long periods of time to reduce the risk of electric shock or fire.

• External Connection

Always use proper ready-made insulated cabling (power cord). Failure to do so could result in shock/death or fire. If in doubt, seek advice from a registered electrician.

• Do not Remove any Covers

Within the product are areas where high voltages may present. To reduce the risk of electric shock do not remove any covers unless the AC mains power cord is removed.

Covers should be removed by qualified service personnel only.

No user serviceable parts inside.

• Fuse

To prevent fire and damage to the product, use only the recommended fuse type as indicated in this manual. Do not short-circuit the fuse holder. Before replacing the fuse, make sure that the product is OFF and disconnected from the AC outlet.

• Protective Ground

Before turning the product ON, make sure that it is connected to Ground. This is to prevent the risk of electric shock. Never cut internal or external Ground wires. Likewise, never remove Ground wiring from the Protective Ground Terminal.

• Operating Conditions

Always install in accordance with the manufacturer's instructions.

To avoid the risk of electric shock and damage, do not subject this product to any liquid/rain or moisture. Do not use this product when in close proximity to water.

Do not install this product near any direct heat source. Do not block areas of ventilation as doing so could result in fire.

Keep product away from open flames.

- **Servicing**

Refer all servicing to qualified service personnel only.

Do not perform any servicing other than those instructions contained within the User's Manual.

IMPORTANT SAFETY INSTRUCTIONS

Read these instructions

Follow all instructions

Keep these instructions. Do not discard.

Heed all warnings.

Only use attachments/accessories specified by the manufacturer.

- **Power Cord and Plug**

Do not tamper with the power cord or plug. These are designed for your safety.

Do not remove Ground connections!

If the plug does not fit your AC outlet seek advice from a qualified electrician.

Protect the power cord and plug from any physical stress to avoid risk of electric shock.

Do not place heavy objects on the power cord. This could cause electric shock or fire.

- **Cleaning**

When required, either blow off dust from the product or use a dry cloth.

Do not use any solvents such as Benzol or Alcohol.

For safety, keep product clean and free from dust.

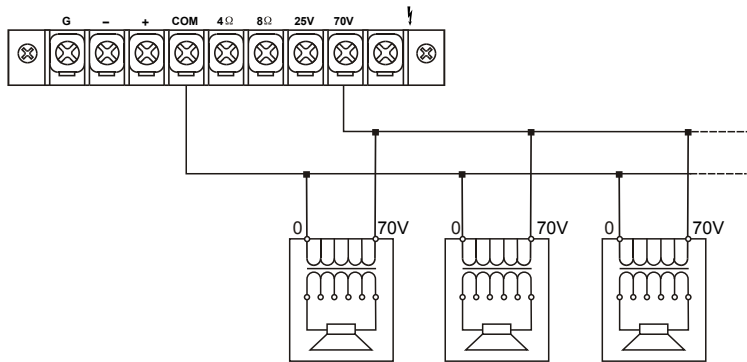

Connecting the speakers with 70V output

19. AC Voltage Selector

In the US, set the AC Voltage Selector to the left (115V) for power between 100V and 127V.

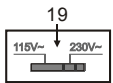

20. Monitor Line Out

Monitor Line Out can be connected with another appliance such as an amplifier, recorder, etc.

21. Monitor 1W8Ω

The terminal is meant for the connection of a small external loudspeaker that gets driven by an internal auxiliary power amplifier, providing a nominal output of 1Watt. This could also be used for a "Music on Hold output." Only the mixed audio signal coming from "AUX IN" is included in the outputted signal.

In addition, the output signal is controlled only by the volume control of the "CH4" & "CH5" music signal level controls.

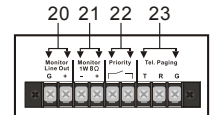

22. "Priority" Terminal.

When these terminals are short-circuited (i.e. By means of using an electrical switch), the audio signals coming from "CH4", "CH5", are attenuated while the signals coming from "CH1", "CH2", "CH3" are gaining priority.

23. Input "AUX Paging"

This terminals input lets you connect to an auxiliary signal. The input features a "Voice Priority" function, which overrides all other input signals once an auxiliary message is sent.

24. a. Zone

There are four dip switches here. Push the dip switch up to switch the zone off and vice versa.

b. Volume

This controls the volume of a sound source connected to the "Tel Paging". Turning the knob clockwise increases the volume of the corresponding source. It is recommend to leave the control of unused inputs at their minimal setting "0".

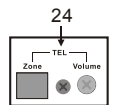

25. "LINE IN" inputs

An audio source with a high level output signal, such as an AM/FM tuner, a cassette deck, a CD player, etc.

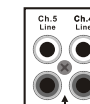

25

SPECIFICATION

Model:	PL200M
Output power capacity:	RMS:40Wx4; Peak output: 90Wx4
Frequency response:	50-17000Hz (-3dB)
Total harmonic distortion:	Less than 0.5%(1KHz-nominal power capacity)
Signal/noise ratio:	Microphone: Better than 55dB rated output Line: better than 60dB rated output
Inputs / sensitivity-impedance:	CH1-3/XLR and 6.3mm combination socket: bal/unbal Mic: -42dB/-38dB-600ohm, bal/unbal. Line: -26B/-20dB-15Kohm, bal/unbal. LINE IN/ stereo RCA jack/ unbalanced CH4: -10dB 50Kohm CH5: 0dB 50Kohm
Tone c	Bass ± 10 dB-100Hz Treble ± 10 dB-10KHz
Outputs for speakers / Ohms:	4 ohm, 8 ohm
Outputs for speakers / Volts:	25V-70V
Monitor output:	1Wrms
Phone output:	0.5W into 47ohm
Line out:	1.2V
Controls:	5 Gain controls for Ch1-5, 7 Volume controls for Ch1-5, tel. pagina, monitor, phone 4 Master volume control 5 Treble controls 5 Bass controls 5 Mute controls 4 Zone select switch for each channel 4 Zone monitor select switch. 1 AC select switch
Indicator:	Power indicator 4 Zone output-level meter 1 Monitor output-level meter 5 Mute indicators
Power supply/ Consumption:	115/230 Vac($\pm 5\%$) -60/50Hz /400VA
Dimensions:	483mm(W) x 132mm(H) x 310mm(D)

Note: Specification, design and appearance are subject to change without prior notice!

The Front panel

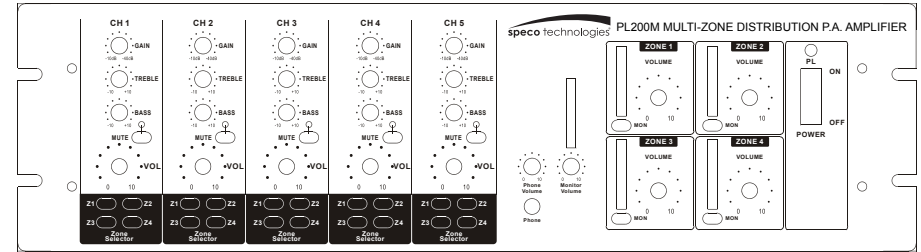

1. Gain knob

This knob controls input gain. Turn the knob clockwise and the input increases. Turn the knob counter-clockwise and the input decreases.

2. High knob

This is the treble control. You can use it to get rid of high frequency noises or to boost the sound of cymbals or the high harmonics of the human voice. The gain range goes from -10dB to 10dB with the central frequency 10kHz.

3. Low knob

This is the Bass control. Boost male voice or kick drum and bass guitar. Your system will sound much bigger than what it is. The gain range goes from -10dB to +10dB and the center frequency is 100 Hz.

4. Mute

Mutes the signals from the corresponding channel.

5. Mute LED

When the mute key is pressed down, mute LED lights up, and vice versa.

6. VOL knob

This knob controls volume. Turn the knob clockwise, and the volume increases. Turn the knob counter clockwise, and the volume decreases.

7. Zone selector

Z1, Z2, Z3, Z4 can be considered as signal assignment switches. Press the button Z1 down and signal will be assigned to ZONE 1. Release the button and it stops assigning signal to ZONE 1. Z2, Z3, Z4 can be operated in the same way.

8. Phone Volume

This knob controls the volume of the signal from the Phone system (refer to 7). Turn the knob clockwise to increase the volume, and vice versa.

9. Phone

The amplifier signals can be sent to a pair of headphones through this socket.

10. Monitor Volume

This knob controls the output signal level to monitor output.

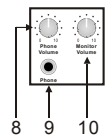
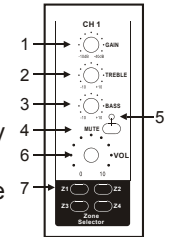

11. Zone1 VOLUME

VOLUME controls the output signal level of ZONE1.

12.LED VU-meter

This stereo 6 segment LED-meter indicates the level of the overall output signal.

13.MONITOR selector

Pushing the MONITOR button down will connect the signal from amplifier zone 1 to the monitor output. Releasing the button will then cut off the signal connection to the monitor. The other three buttons are operated in the same way.

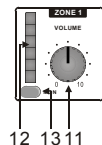

14. PL

This LED is the power indicator. When the amplifier is powered on, this LED lights up. When the amplifier is powered off, this LED lights off.

15. Power switch

When the switch is set in the position ON, the unit is powered on. When the switch is set in the position OFF, the unit is powered off.

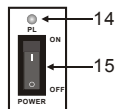

The Rear Panel

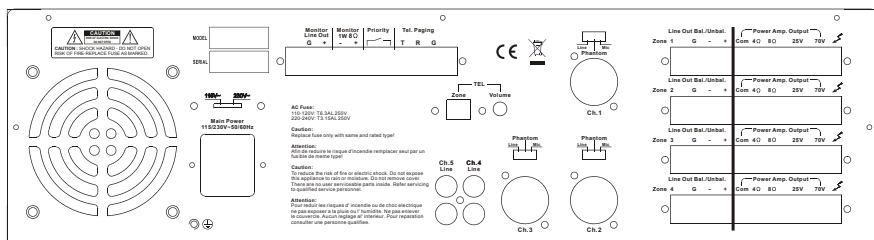

16. Intelligent fan

The PL200M is equipped with an intelligent fan. It will only begin to run if the temperature is above 50 degrees C, and the speed of the fan will increase as the temperature rises.



16

17. AC Input

This inlet connects the unit with the main power.

18. AC fuse

The fuse protects the alternating current circuit of the unit, and the fuse can only be replaced in the event of fuse damage.

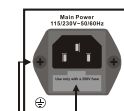

17

18

INSTALLATION NOTES

The amplifier must be operated under appropriate conditions at all times. This means that the installation location must provide sufficient ventilation and the device is not exposed to direct sunlight or the direct radiation or reflection from any heat source. When installing the loudspeaker systems, choose a location that will not be affected by extreme and/or constant vibration or other mechanical oscillation. Also make sure that the speakers are installed at locations that are free from dust and /or moisture.

CAUTION

We strongly recommend that you leave the installation of the PL200M system to qualified and experienced service technicians who specialize in connecting electronic equipment. Do not take the risk of Electro-shock. To reduce this risk, all connections should be made before connecting the amplifier to the main power supply. Be sure that all connections are correct and that no short-circuit exists. The overall sound reinforcement installation must be in accordance to the laws, regulations, standards, and guidelines that are relevant and applicable in the jurisdiction where the equipment is going to be operated.

AC POWER SUPPLY CAUTION

Before using the amplifier for the first time, make sure that the appliance voltage is correct. Only connect the amplifier to grounded outlets. Connection of the amplifier to the main power supply (115/230Vac) has to be accomplished by inserting the supplied cord into the corresponding socket.

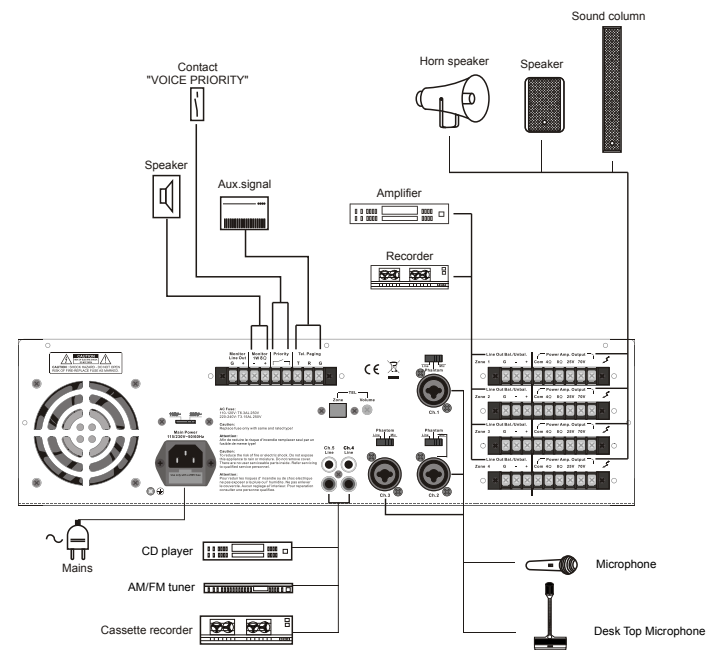

26. The mono MIC/LINE channels

The channels are numbered from 1 to 4. You can connect balanced, low impedance microphones to the XLR socket. On the 1/4" phone jack you can connect either a microphone or a line level instrument. You should never connect an unbalanced microphone to the XLR socket as it could damage both the Microphone and the Mixer.

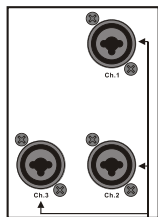

26

27. Ch1, CH2, CH3 and inputs sensitivity and XLR phantom switch

By turning the switch onto the "LINE" position the CH1, CH2, & CH3 inputs can be connected to an audio source with a high level signal output. By turning these switches to the MIC position, CH1, CH2, & CH3 inputs can be connected to a dynamic microphone with low impedance. By turning the switch into the "Phantom" position, it connects the phantom power supply for XLR pin2 and pin3 of CH1, CH2, & CH3, which is necessary to operate condenser microphones. It is recommended to activate this switch with the general volume set to zero.

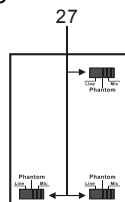

27

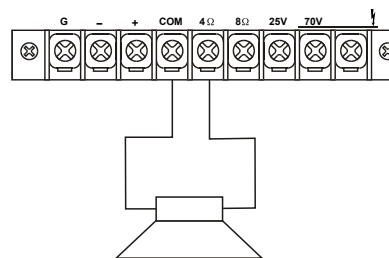

Total impedance: 4 ohms

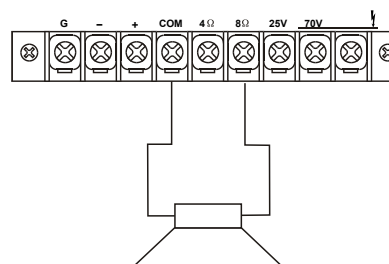

Total impedance: 8 ohms

28. Line Out Bal/Unbal

These terminals can be connected to other appliances, such as amplifiers, recorders, etc.

29. Power Amp Output

These terminals allow for the connection of speakers.

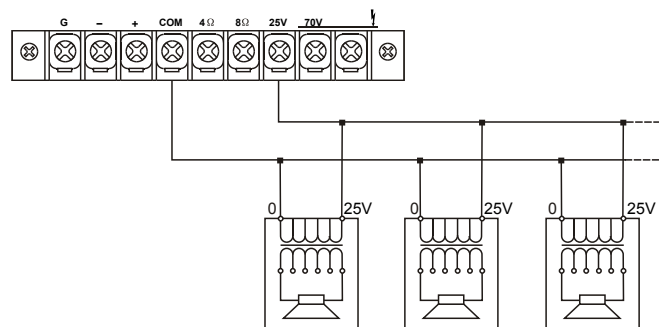
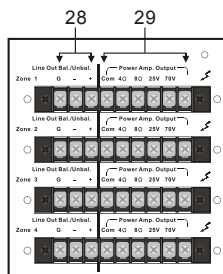

Connecting the speakers with 25V output