

# *PS-20*

*Power Supply*

*User Manual*



**PROPRIETARY NOTICE**

The product information and design disclosed herein were originated by and are the property of Bosch Security Systems, Inc. Telex reserves all patent, proprietary design, manufacturing, reproduction, use and sales rights thereto, and to any article disclosed therein, except to the extent rights are expressly granted to others.

**COPYRIGHT NOTICE**

Copyright 2009 by Bosch Security Systems, Inc. All rights reserved. Reproduction, in whole or in part, without prior written permission from Bosch is prohibited.

**WARRANTY NOTICE**

See the enclosed warranty card for further details.

**CUSTOMER SUPPORT**

Technical questions should be directed to:

Customer Service Department  
 Bosch Security Systems, Inc.  
 12000 Portland Avenue South  
 Burnsville, MN 55337 U.S.A.  
 info@rtsintercoms.com  
 Telephone: 800-392-3497  
 Fax: 800-323-0498  
 Factory Service: 800-553-5992

Technical Questions EMEA:  
 Bosch Security Systems, Technical Support EMEA  
[http://www.rtsintercoms.com/contact\\_main.php](http://www.rtsintercoms.com/contact_main.php)

**RETURN SHIPPING INSTRUCTIONS**

Customer Service Department  
 Bosch Security Systems, Inc. (Lincoln, NE)  
 info@rtsintercoms.com  
 Telephone: 402-467-5321  
 Fax: 402-467-3279  
 Factory Service: 800-553-5992

Please include a note in the box which supplies the company name, address, phone number, a person to contact regarding the repair, the type and quantity of equipment, a description of the problem and the serial number(s).



**SHIPPING TO THE MANUFACTURER**

All shipments of product should be made via UPS Ground, prepaid (you may request from Factory Service a different shipment method). Any shipment upgrades will be paid by the customer. The equipment should be shipped in the original packing carton. If the original carton is not available, use any suitable container that is rigid and of adequate size. If a substitute container is used, the equipment should be wrapped in paper and surrounded with at least four (4) inches of excelsior or similar shock-absorbing material. All shipments must be sent to the following address and must include the Proof of Purchase for warranty repair. Upon completion of any repair the equipment will be returned via United Parcel Service or specified shipper, collect.

Factory Service Department  
 Bosch Security Systems, Inc.  
 8601 Cornhusker Hwy.  
 Lincoln, NE 68507 U.S.A.  
 Attn: Service

This package should include the following:

Part No.	Description	Qty
90007854000 or 90007854100 or 90007854200	US Power Cord  Euro Power Cord  UK Power Cord	1
90107854000	Final Assy, PS-20	1
550006100	Power Cord	1
93506786100	User Manual	1
38110387	Warranty Statement	1

 <p>THE LIGHTNING FLASH AND ARROWHEAD WITHIN THE TRIANGLE IS A WARNING SIGN ALERTING YOU OF "DANGEROUS VOLTAGE" INSIDE THE PRODUCT.</p>	<p><b>CAUTION</b></p> <p><b>RISK OF ELECTRIC SHOCK DO NOT OPEN</b></p> <p>CAUTION: TO REDUCE THE RISK OF ELECTRIC SHOCK, DO NOT REMOVE COVER. NO USER-SERVICABLE PARTS INSIDE. REFER SERVICING TO QUALIFIED SERVICE PERSONNEL.</p>	 <p>THE EXCLAMATION POINT WITHIN THE TRIANGLE IS A WARNING SIGN ALERTING YOU OF IMPORTANT INSTRUCTIONS ACCOMPANYING THE PRODUCT.</p>
SEE MARKING ON BOTTOM/BACK OF PRODUCT		

**WARNING: TO PREVENT FIRE OR ELECTRICAL SHOCK HAZARD, DO NOT EXPOSE THIS PRODUCT TO RAIN OR MOISTURE.**

	This product is AC only
---	-------------------------

## *Important Safety Instructions*

1. Read these instructions.
2. Keep these instructions.
3. Heed all warnings.
4. Follow all instructions.
5. Do not use this apparatus near water.
6. Clean only with dry cloth.
7. Do not block any ventilation openings. Install in accordance with the manufacturer's instructions.
8. Do not install near any heat sources such as radiators, heat registers, stoves, or other apparatus (including amplifiers) that produce heat.
9. Do not defeat the safety purpose of the polarized or grounding-type plug. A polarized plug has two blades with one wider than the other. A grounding type plug has two blades and a third grounding prong. The wide blade or the third prong are provided for your safety. If the provided plug does not fit into your outlet, consult an electrician for replacement of the obsolete outlet.
10. Protect the power cord from being walked on or pinched particularly at plugs, convenience receptacles, and the point where they exit from the apparatus.
11. Only use attachments/accessories specified by the manufacturer.
12. Use only with the cart, stand, tripod, bracket, or table specified by the manufacturer, or sold with the apparatus. When a cart is used, use caution when moving the cart/apparatus combination to avoid injury from tip-over.
13. Unplug this apparatus during lightning storms or when unused for long periods of time.
14. Refer all servicing to qualified service personnel. Servicing is required when the apparatus has been damaged in any way, such as power-supply cord or plug is damaged, liquid has been spilled or objects have fallen into the apparatus, the apparatus has been exposed to rain or moisture, does not operate normally, or has been dropped.



# Table of Contents

---

<i>IMPORTANT SAFETY INSTRUCTIONS</i> .....	III
<b>INTRODUCTION</b> .....	<b>3</b>
<i>Description</i> .....	3
<i>Features</i> .....	4
<i>Reference View</i> .....	5
<i>Specifications</i> .....	6
<i>Installation</i> .....	7
<i>MECHANICAL INSTALLATION</i> .....	7
<i>ELECTRICAL INSTALLATION</i> .....	7
<i>USING TWO (2) PS-20S AND AUDIO LINKING 2-WAY COMMUNICATIONS</i> .....	7
<i>Channel Configuration</i> .....	10
<i>Termination Impedance</i> .....	12
<i>Configuration Diagrams</i> .....	14
<b>OPERATION AND MAINTENANCE</b> .....	<b>15</b>
<i>Power-up Indications</i> .....	15
<i>Fault Indications</i> .....	15
<i>Monitor Output</i> .....	15
<i>Mode Selection Switch</i> .....	15
<i>Termination Impedance Switch</i> .....	16
<i>Program Input</i> .....	16
<i>Maintenance</i> .....	16
<i>SAFETY CONSIDERATIONS</i> .....	16
<i>ACCESS</i> .....	16

---



---

*Description*

The PS-20 is a complete and independent power supply, with the added features of 2- and 4-channel operation, monitoring, 2-channel program input, audio linking and three (3) modes of operation: RTS 2-channel, RTS 4-channel and Clear-Com mode.

The PS-20 features two (2) channels of communication where both channels are *wet*, meaning there is power on each channel (RTS 2-channel mode). In RTS 4-channel mode, the audio signals and DC exist on the same wire, unlike in Clear Com mode, where the audio and power are on separate lines. Where the PS-15 has power on CH 1 only, power is on both CH 1 and CH 2 on the PS-20.

The PS-20 has a 3-pin XLR (male) connector on the front of the system, where a user can connect to the power supply and monitor activity on CH 1 or CH 2 (see Figure 1 on page 5). In Clear-Com mode, only channel one (1) is heard. A user station or beltpack is required to use a headset with this feature.

A single PS-20 Power Supply can power up to 50 user stations (depending on the model and combination - see specifications). If still more user stations or beltpacks are needed, two PS-20 Power Supplies can be joined together to double the power capability.

A pair of standard stereo plug connectors are available on the back of the power supply to connect two (2) PS-20 power supplies through audio linking.

The PGM IN (3-pin XLR female) connector can be used to send Audio to CH 1 and/or CH 2 (for example, a radio station users can listen to while they work).

---

## Features

### **Selectable Mode Operation -**

The PS-20 is selectable between RTS 2-channel, RTS 4-channel and Clear-Com mode.

### **Audio Linking -**

Audio Linking allows you to connect up to two (2) PS-20s with a standard stereo cable. There is an Audio Link for CH1 and CH2 and an Audio Link for CH3 and CH4 connection for two way communications. To learn how to configure Audio Linking, Figure 2, "Audio Linking Two-way communication configuration.," on page 8

### **Monitoring -**

The 3-pin XLR Monitoring Output connector allows the user to monitor a channel or channels. A user station or beltpack is required to use a headset with this feature.

**NOTE:** In Clear-Com mode, only channel one (1) is heard.

### **Status Indicators -**

There is a green status indicator for each channel. Each of these indicators remains lit during normal operation, but turns RED during a channel current overload condition. Output current is automatically reduced during an overload, and normal operation is restored when the overload is removed.

### **Program Input -**

There is a Program Input connector on the rear panel. This can be used to connect a device that both channel 1 and channel 2 can listen to at the same time (for example, a radio). A Channel Select switch on the front panel assigns the program to either or both channels. A Level control adjusts the program level to the intercom channel.

### **Intercom Channels Connections -**

Intercom channels are connected to the rear panel of the PS-20 with 3-pin XLR connectors.

### **Selectable Termination Impedance -**

The IMPEDANCE SELECT switch on the rear panel allows each channel to be set for 200  $\Omega$  or 400  $\Omega$  operation. Select 200  $\Omega$  for each channel operated independently. Select 400  $\Omega$  for each channel connected to another channel.



## Reference View

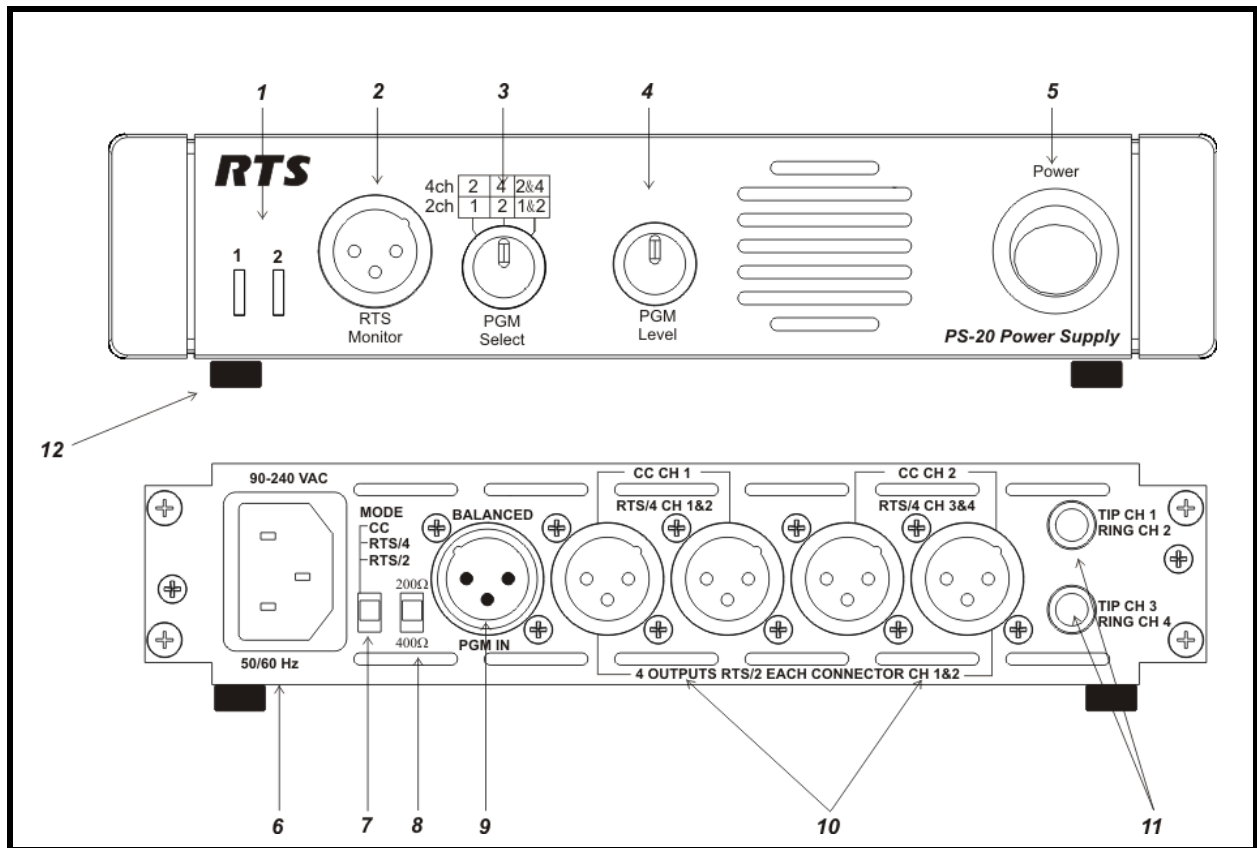

FIGURE 1. PS-20 Reference View

1. **Channel Indicator LEDs** - Provides a visual indication of the channel DC power. A green LED displays for normal operation and a red LED displays when there is an overload or short circuit.
2. **Monitor Output** - Front panel connection for system administrator to listen (can talk as well) to channel 1, channel 2 or both. This is a 3-pin XLR (male). In Clear-Com mode, only channel one (1) is heard. A user station or beltpack is required to use this feature.
3. **Channel Select** - Use the channel switch to select channel 1, channel 2 or both channels. The channel select determines which channel the Program Input is connected
4. **Level Control** - Controls the volume of the program output selected: channel 1, channel 2, or both.
5. **ON/OFF switch** - Powers the PS-20 power supply.
6. **AC Connection** - This unit accepts any input power in the range of 90 to 240 VAC, 50 to 60 Hz.
7. **Mode Selection Switch** - Allows you to select between RTS 2 channel, RTS 4 channel or Clear-Com modes of operation. For more on Modes of Operation, see "Mode Selection Switch" on page 15.
8. **Termination Impedance Switch** - Allows you to select between either 200Ω or 400Ω. 400Ω impedance termination is most commonly used when connecting two channels on two (2) different PS-20s together.
9. **PGM IN** - A 3-pin XLR (female) connection allows the user to put a program source (i.e., a radio) on the channels.
10. **Output Connectors** - Channel 1 and Channel 2 Output connectors can be configured to work in RTS-TW 2-channel, RTS-TW 4-channel, or Clear-Com mode. These are 3-pin XLR (male).
11. **Audio Link CH1&2 and CH3&4** - Connects up to two PS-20s together. For more information, see Figure 2 on page 8.
12. **Rubber Adhesive Feet** - The unit can be rack-mounted or can use feet for desktop usage. For more information on rack mounting options, see Figure 7 on page 13.

---

# Specifications

## General

### Input Voltage:

90 to 240 VAC, 50 to 60 Hz

### Output Voltage:

28 VDC to 32 VDC

### Output Current:

1.80 Amps Maximum per channel

### Termination Impedance:

Selectable 200  $\Omega$  / 400  $\Omega$

### Ripple:

< 0.2 V

### Program Input Levels:

Nominal +2 dBu  
Balanced, High Impedance >10 k $\Omega$

### Two-Wire Output Levels:

Nominal 30 VDC  
Unbalanced, selectable 200  $\Omega$  / 400  $\Omega$

### Monitor Output:

Nominal Gain of 0 dB for 1000 mVRMS input level on the program input. 30 VDC nominal, 100 mA maximum.

### Audio Link

Nominal input 2 dBu with a Gain of 0 dB

## Connections

Type: 3-pin XLR male (RTS 2-channel Mode)

Pin 1 Common for Audio and DC  
Pin 2 30 VDC and Mixed Audio Channel 1  
Pin 3 30 VDC and Mixed Audio Channel 2

Type: 3-pin XLR male (RTS 4-channel Mode)

Pin 1 Common for Audio and DC  
Pin 2 30 VDC and Mixed Audio Channel 1 or 3  
Pin 3 Mixed Audio Channel 2 or 4

Type: 3-pin XLR male (Clear-Com Mode)

Pin 1 Common for Audio  
Pin 2 30 VDC  
Pin 3 Mixed Audio Channel 1 or 2

## Program Input

Type: 3-pin XLR female

Pin 1 Common  
Pin 2 Balanced Audio + Input  
Pin 3 Balanced Audio - Input

## Audio Link

Input 1/4" Stereo Phono Jack

Tip: Channel 1  
Ring: Channel 2  
Sleeve: Ground

Output 1/4" Stereo Phono Jack

Tip: Channel 3  
Ring: Channel 4  
Sleeve: Ground

## AC Input

Type: Universal AC Plug

Pin 1 Hot  
Pin 2 Neutral  
Pin 3 Earth Ground

## Monitor Output

Type: 3-pin XLR male (RTS 2-channel Mode)

Pin 1 Common for Audio and DC  
Pin 2 30 VDC and Mixed Audio Channel 1  
Pin 3 30 VDC and Mixed Audio Channel 2

Type: 3-pin XLR male (RTS 4-channel Mode)

Pin 1 Common for Audio and DC  
Pin 2 30 VDC and Mixed Audio Channel 1  
Pin 3 Mixed Audio Channel 2

Type: 3-pin XLR male (Clear-Com Mode)

Pin 1 Common for Audio  
Pin 2 30 VDC  
Pin 3 Mixed Audio Channel 1

## Environmental

Operating Temperature

0° C - 50° C (32° F to 122° F)

Storage

-40° C to 70° C (-40° F to 158° F)

Humidity

0 to 95%, non-condensing

## Dimensions and Finish

Height

1.72 inches (44 mm) - 1 RU

Width

8.186 inches (207.9 mm)

Weight

Under 5lbs.

Finish

Thermoplastic front panel, Aluminum case, RTS light gray paint - black silk screen.

Mounting - MCP Style rack kit or (included rubber adhesive feet).

## Approvals and Listings

CE (Conformité Européenne)  
UL (Underwriters Laboratory)  
CSA (Canadian Standards Associations)  
WEEE (Waste Electrical and Electronics Equipment)  
ROHS (Restriction of Hazardous Substances)

---

## *Installation*

### **Mechanical Installation**

The PS-20 Power Supply can be rack mounted or used free standing. For rack configurations, see Figure 7, “Rack Mount Configurations for the PS-20,” on page 13. Allow room for cable connections.

### **Electrical Installation**

#### **Connecting Intercom Stations**

**NOTE:** When connecting intercom stations, do not exceed the power supply capacity, either for channel 1, channel 2 or both. Power supply capacity is graphically illustrated in Figure 3 on page 9.

Connect intercom channels to the output connectors on the rear panel, see Figure 8, “Configuration Diagrams,” on page 14

#### **Using Two (2) PS-20s and Audio Linking 2-way communications**

When using the Audio Linking configuration, you can connect two (2) PS-20s, to double the load capacity of a channel so more user stations can be added.

Pin out assignments are as follows:

Input 1/4” Stereo Phono Jack

Link 1/2      Tip:    Channel 1  
                  Ring:    Channel 2  
                  Sleeve: Ground

Output 1/4” Stereo Phono Jack

Link 3/4      Tip:    Channel 3  
                  Ring:    Channel 4  
                  Sleeve: Ground

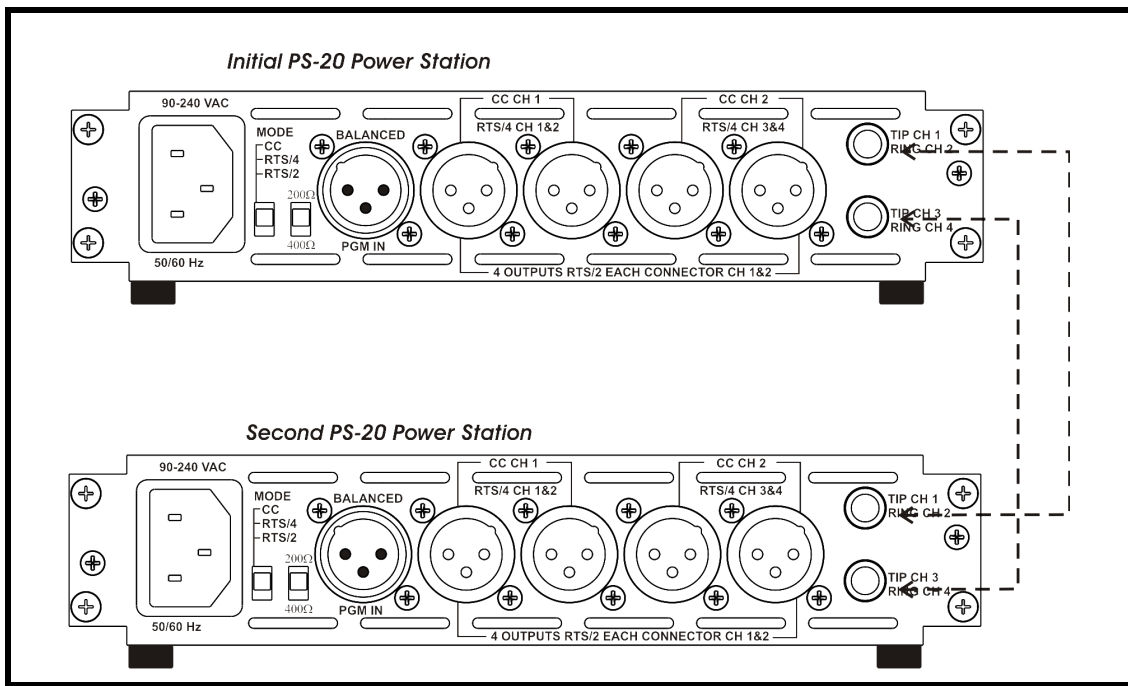

**FIGURE 2.** Audio Linking Two-way communication configuration.

### Program Inputs

A program source may be connected to the PROGRAM INPUT connector on the rear panel. Pin assignments are as follows:

- Pin 1 = common/ground
- Pin 2 = balanced audio +input
- Pin 3 = balanced audio -input

To **connect an unbalanced program source**, do the following:

1. Connect **pin 3** to **pin 1**.
2. Connect **program ground** to **pin 1** and **program +** to **pin 2**.

### AC Power

Plug the AC power cord into the PS-20 and into an AC mains outlet.

**NOTE:** The PS-20 is capable to run at 90 to 240 VAC, therefore, operation at 100-110 volts or 200-220 volts does not require any modification or change. Refer to “Maintenance” on page 16.

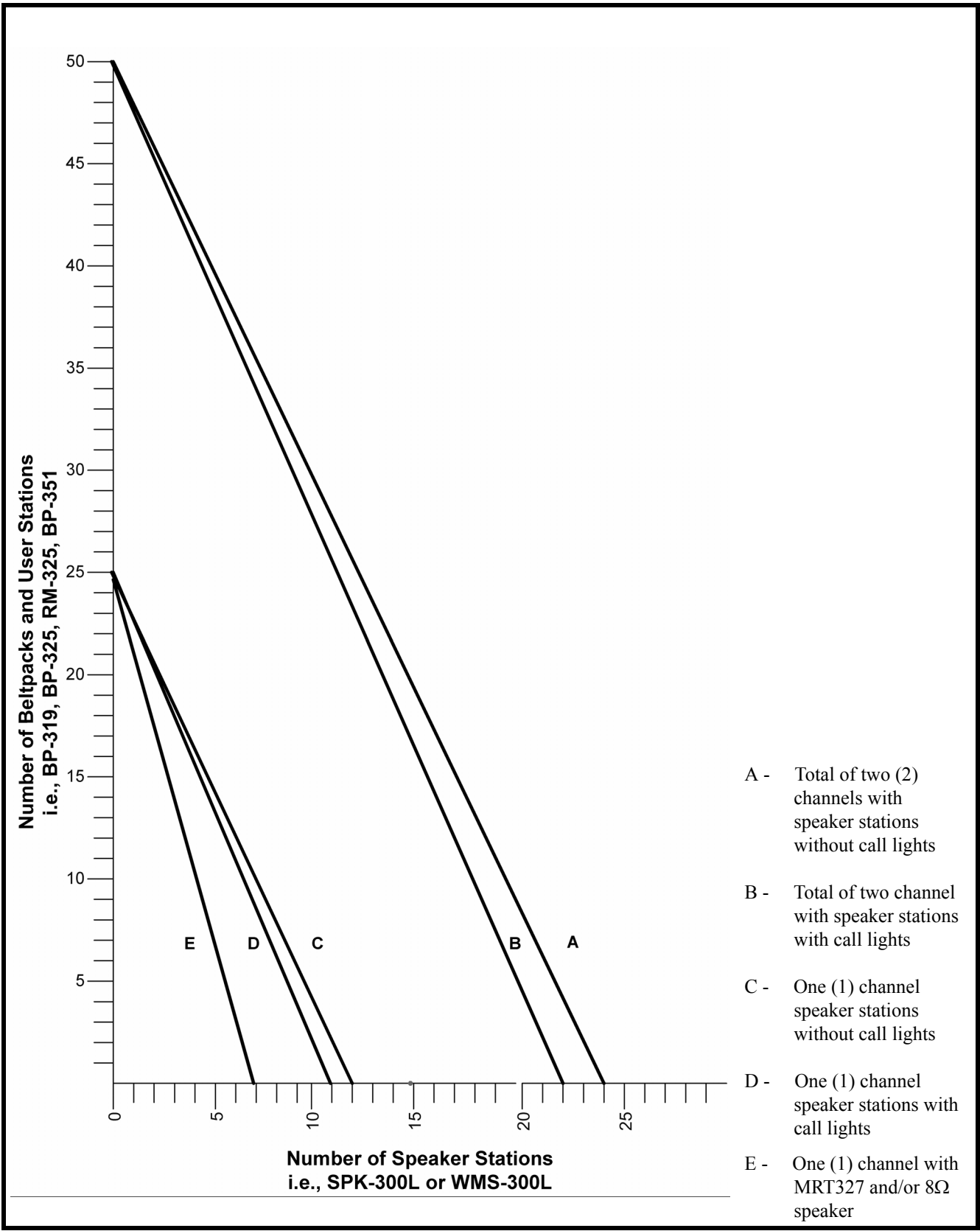

FIGURE 3. Capacity Graph

## Channel Configuration

The PS-20 is capable of three different modes of operation, RTS-TW 4-channel mode, RTS-TW 2-channel mode, and Clear-Com 2-channel mode (see Figure 4).

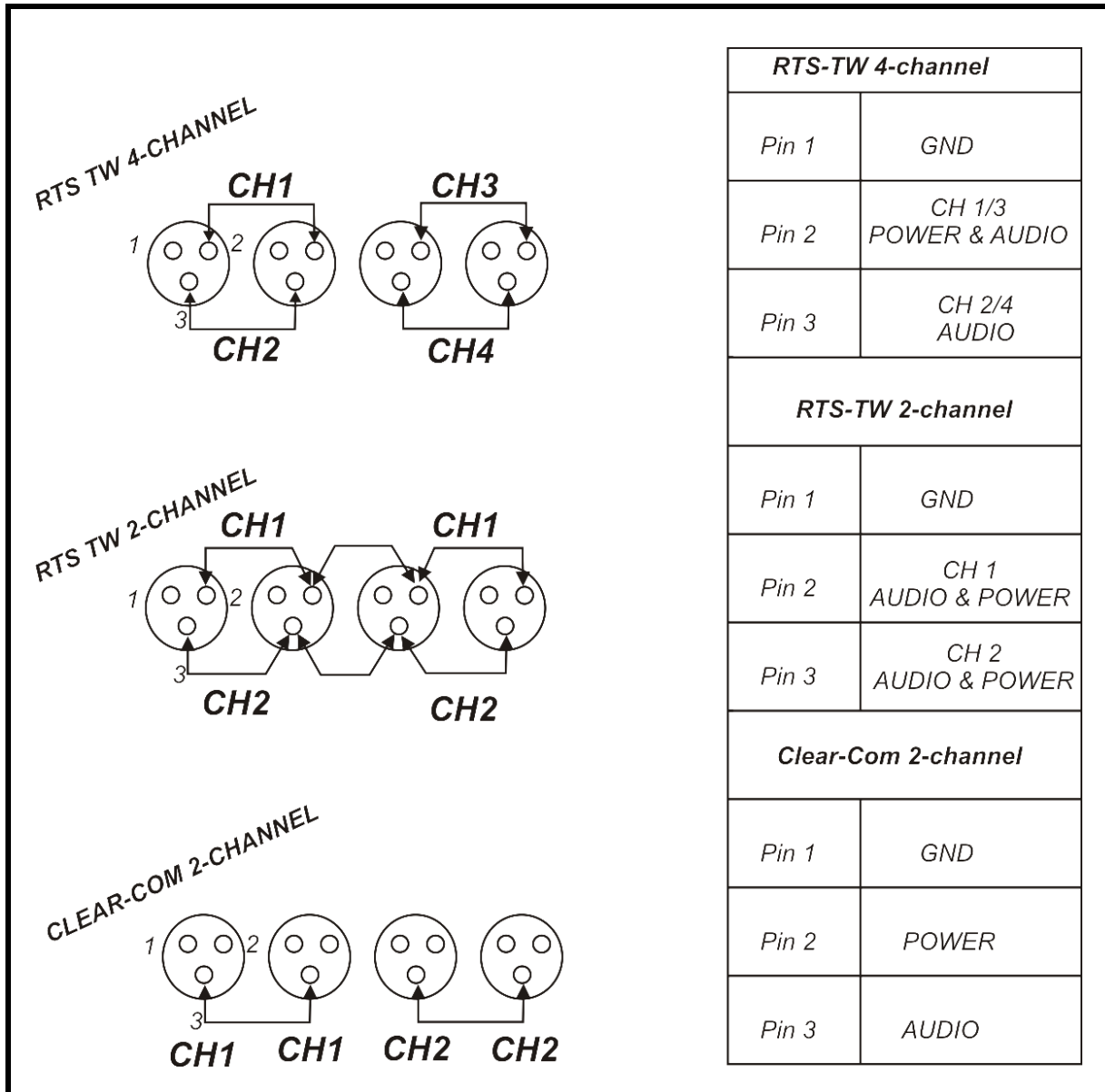
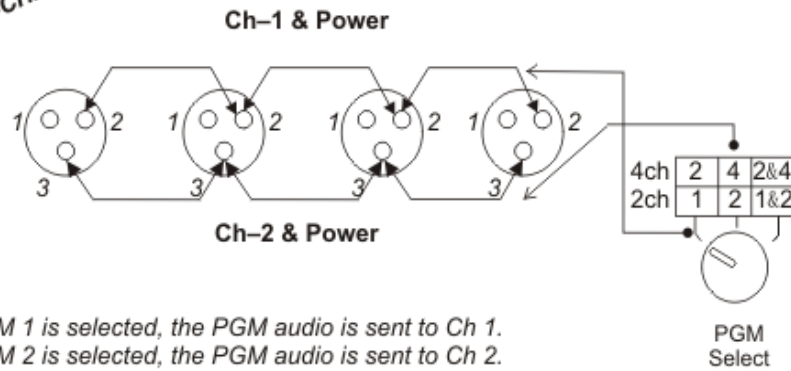

FIGURE 4. Channel Configuration

**RTS-TW 2-CHANNEL MODE**



When PGM 1 is selected, the PGM audio is sent to Ch 1.  
 When PGM 2 is selected, the PGM audio is sent to Ch 2.

**RTS-TW 4-CHANNEL MODE**

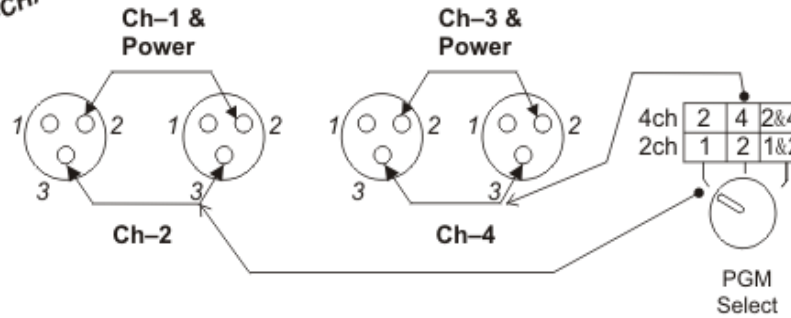

When PGM 1 is selected, the PGM audio is sent to Ch 2.  
 When PGM 2 is selected, the PGM audio is sent to Ch 4.

**CLEAR-COM 2-CHANNEL MODE**

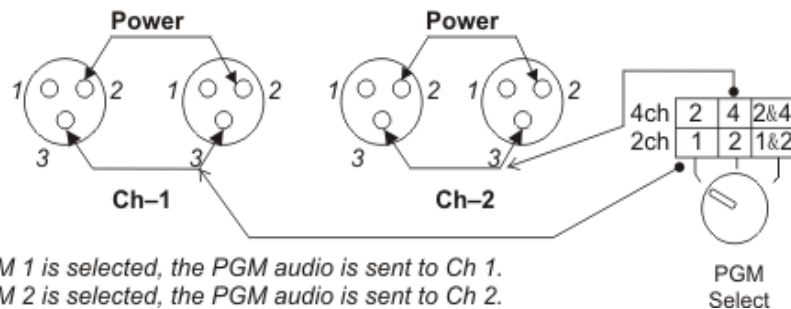

When PGM 1 is selected, the PGM audio is sent to Ch 1.  
 When PGM 2 is selected, the PGM audio is sent to Ch 2.

**FIGURE 5.** Intercom and PGM Channel Settings

## Termination Impedance

When connecting two (2) channels on a PS-20, the termination switch must be set to  $400\Omega$  to account for double termination. By setting the termination impedance at  $200\Omega$  over two (2) channels, the power load would decrease to  $100\Omega$  ( $1/200 + 1/200 = 2/200 = 1/100$ ). However, by setting the termination switch to  $400\Omega$  when operating over two (2) channels the impedance to each channel is increased to  $200\Omega$  ( $1/400 + 1/400 = 2/400 = 1/200$ ). For more information on cable wiring, see Figure 4 on page 10.

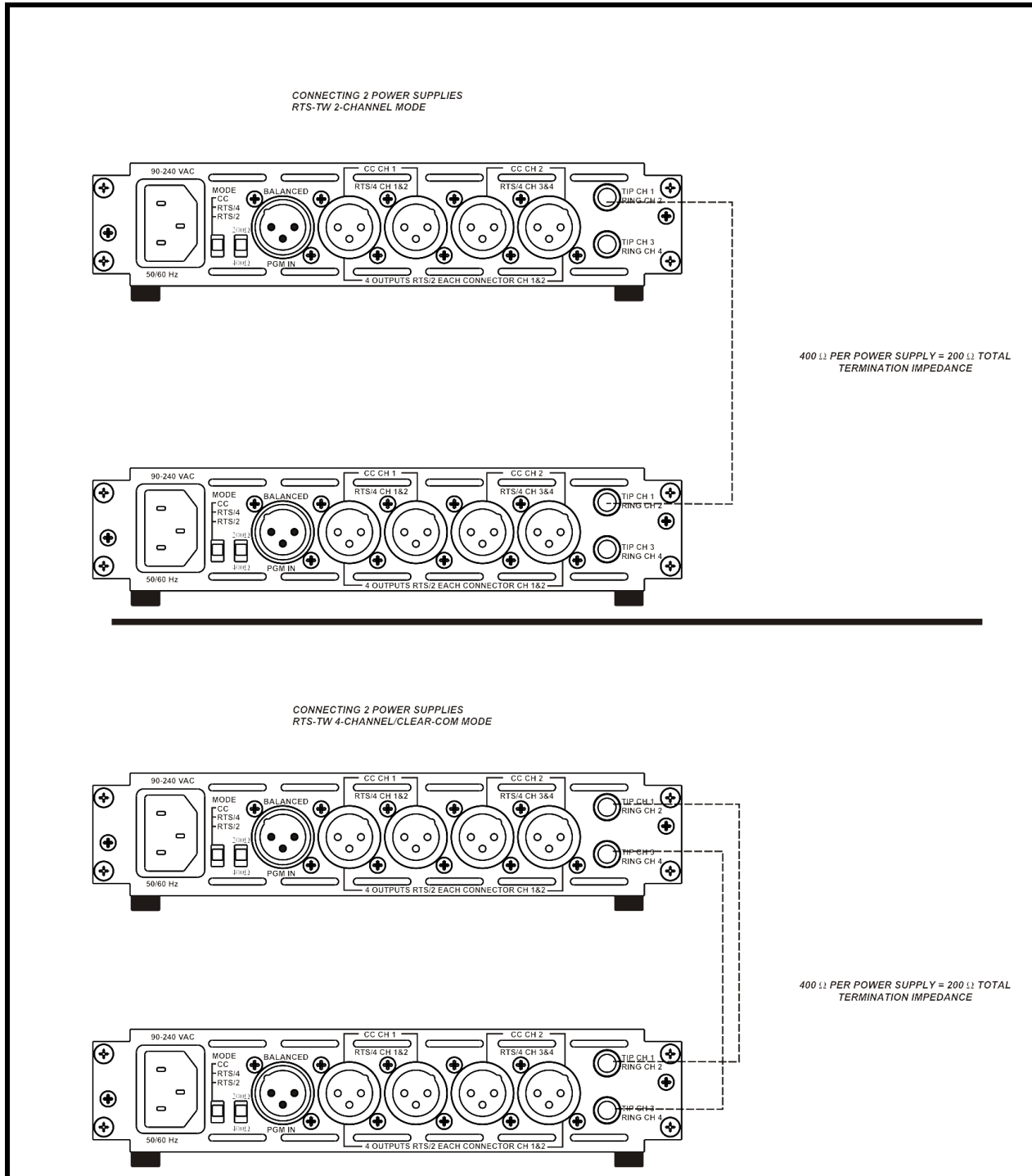

**FIGURE 6.** Termination Impedance Configuration Diagram



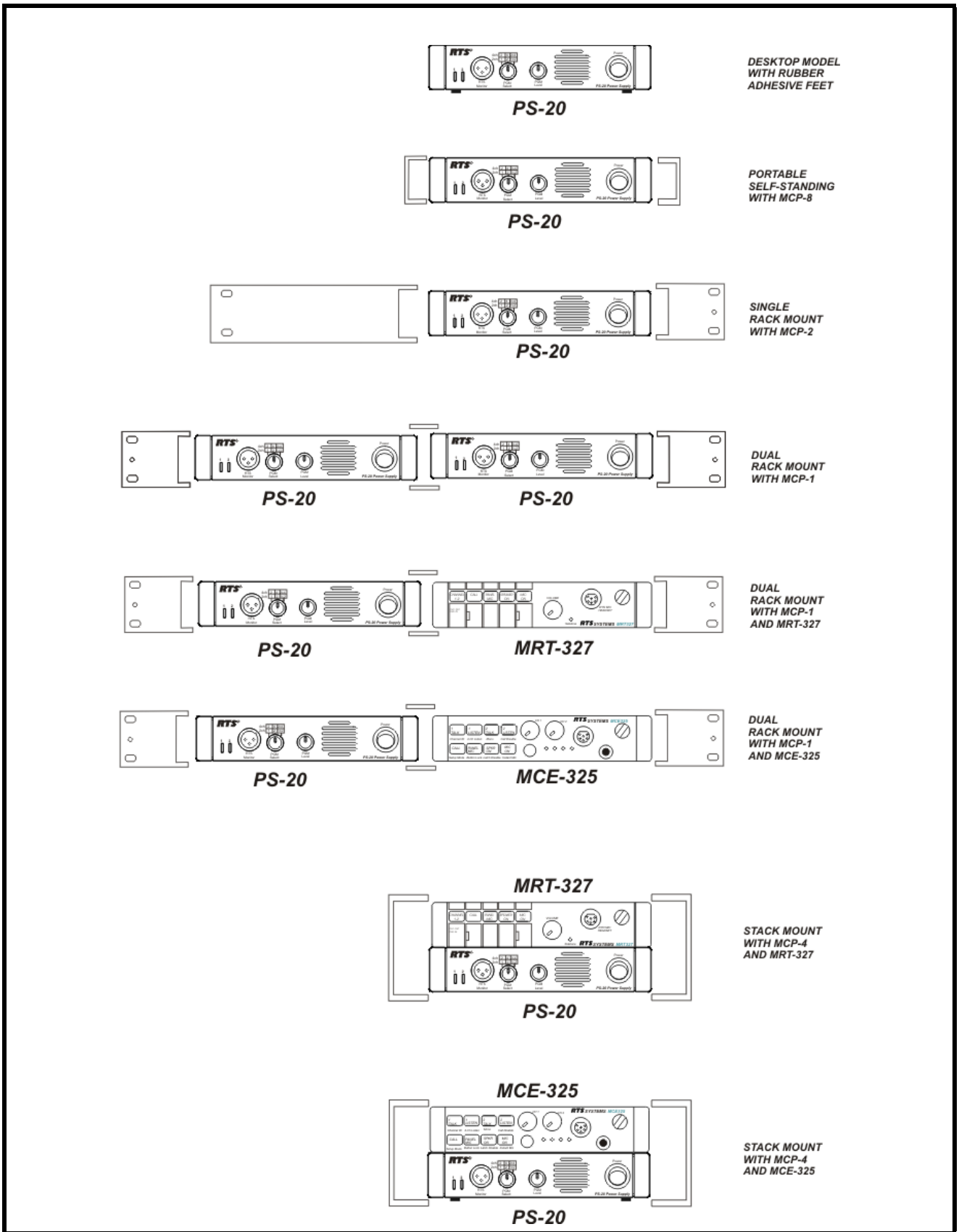

FIGURE 7. Rack Mount Configurations for the PS-20.

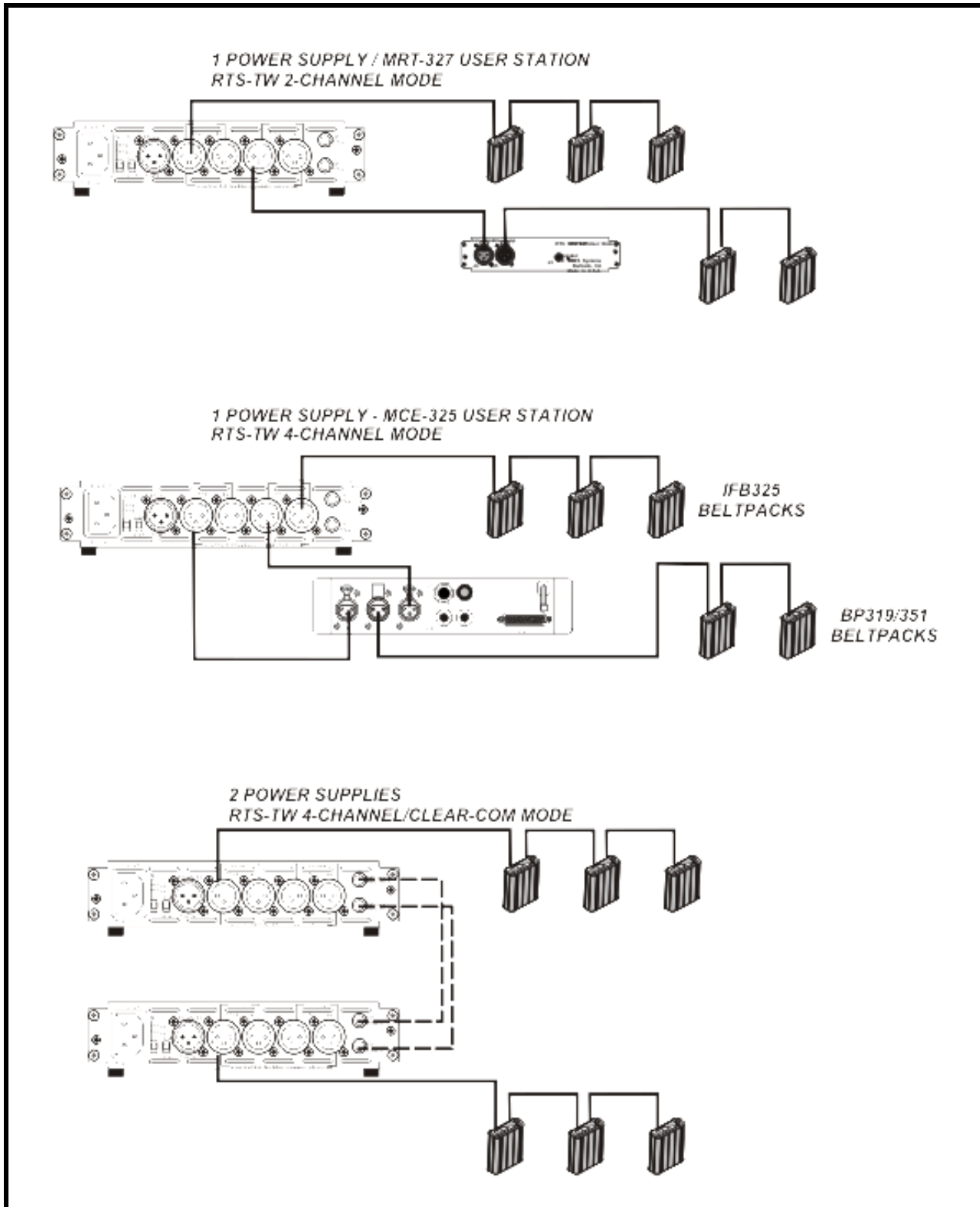

FIGURE 8. Configuration Diagrams

# *Operation and Maintenance*

---

---

## *Power-up Indications*

Turn on the Power switch. During normal operation, the two (2) CHANNEL STATUS indicators light green.

---

## *Fault Indications*

If there is a fault on a channel, the CHANNEL STATUS indicator for that channel turns red.

Possible causes of a fault include:

- over voltage
- over current
- short circuit to ground
- severe brown-outs

---

## *Monitor Output*

Use the monitor output to monitor channel 1, channel 2, or both channels at the same time.

RTS 4-channel mode - You can only monitor channels 1 and 2.

Clear-Com mode - You can only monitor channel 1.

**NOTE:** A user station or beltpack is required to use this feature.

---

## *Mode Selection Switch*

The PS-20 has a 3-position mode selection switch where you can choose the mode in which to operate. You can choose between RTS-TW 2-channel mode, RTS-TW 4-channel mode or Clear-Com mode. For channel configuration information, see “Channel Configuration” on page 10.

---

## *Termination Impedance Switch*

Termination Impedance is necessary when two (2) channels of power are connected (whether between two (2) PS20s, or on the same unit). When connecting channels, the termination switch should be set at  $400\Omega$ , so it equals  $200\Omega$  on each channel.

For more information on termination impedance, see “Termination Impedance” on page 12.

---

## *Program Input*

If a program source is connected to the PROGRAM INPUT connector on the back of the PS-20, it may be routed to either CH1, CH2 or both using the CHANNEL SELECT switch. Use the LEVEL control to adjust the program level on the selected channel.

**NOTE:** In 4-channel mode, the program input is routed to CH2, CH4, or both. For more information, see Figure 5 on page 11.

---

## *Maintenance*

### **Safety Considerations**

Service should be performed only by qualified service personnel.

Any adjustment, maintenance, and repair of the opened equipment while any power or voltage is applied should be avoided as much as possible, and should be carried out only by a skilled person who is aware of the hazard involved.

It is possible for capacitors inside the equipment to still be charged even if the equipment has been disconnected from its power source.

### **Access**

To **open the PS-20**, do the following:

1. Remove the **screws** on the top and bottom covers.
2. Slide **covers** off toward the back of the unit.

# PS-20 Quick Start

**NOTE:** This quick start is to be used to get your PS-20 unit initially set and running. Further configuration may be needed for more advanced operation.

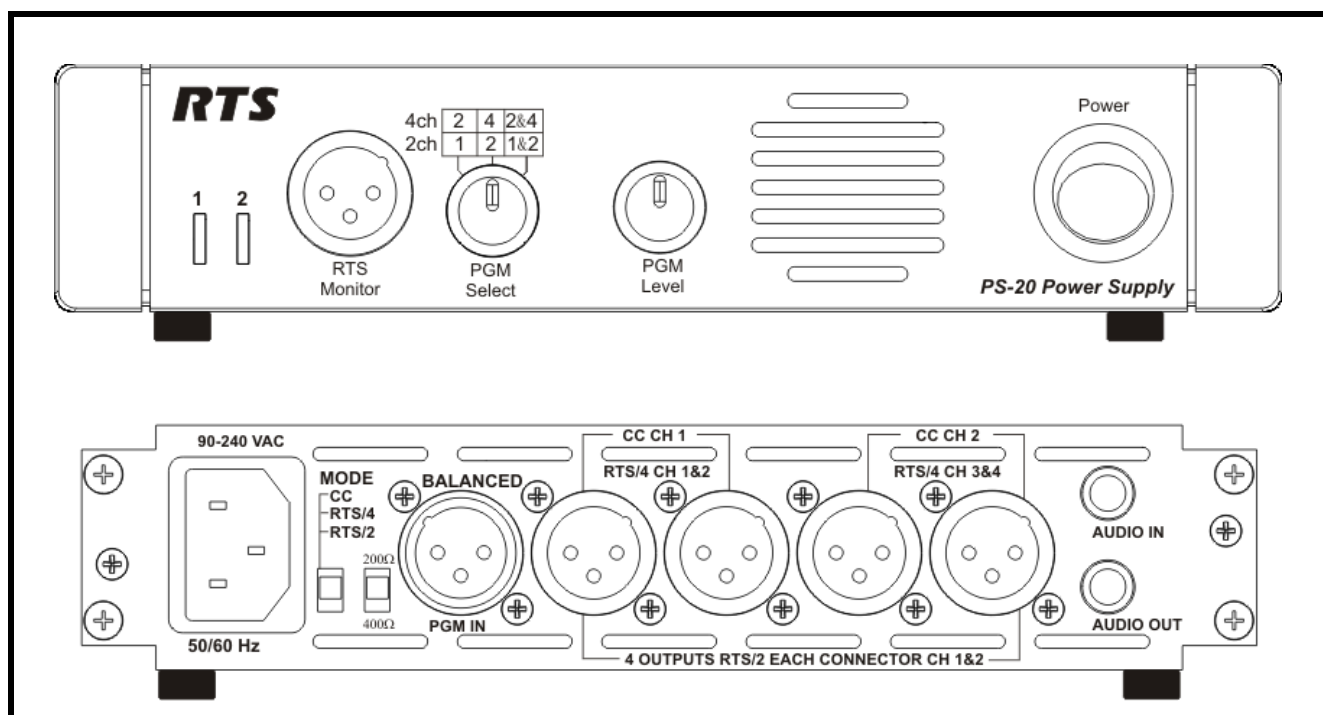

On the back of the PS-20 unit:

**NOTE:** On the front of the PS-20 unit, verify the Power Switch is turned off.

1. Connect the **supplied power cord** to the unit, and then plug the unit into the desired power outlet.
2. Select the **mode** in which you want the unit to operate, *CC* (Clear-Com), *RTS/4* (RTS 4-channel), or *RTS/2* (RTS 2-channel).

**NOTE:** For an overview of the channel modes, see Figure 4, “Channel Configuration,” on page 10.

3. Select the **Termination Impedance**, either  $200\Omega$  or  $400\Omega$
4. Using Figure 8 on page 14, configure the **external devices** you want to use with the PS-20 unit.
5. If using an external audio source you want both channel 1 and channel 2 to hear, connect the **device** using the PGM IN connection on the back of the PS-20 unit.
6. Turn the PS-20 **on**.

