

PPA T45NET / PPA T45

Personal PA® DSP FM Wideband Transmitter

USER MANUAL

Transmitter Models PPA T45NET and PPA T45
Optional Receiver Models PPA R38, PPA R37, PPA R35-8, PPA R1600



Table of Contents

System Connection Overview	6
Figure 1: Typical System Example.....	6
Wiring and Connections	7
Power Supply Connection	7
Ethernet Connection	7
Audio Source Connections	7
Figure 2: PPA T45NET Rear View.....	7
Multi-Channel Sources	8
Selecting an Audio source Appropriate for Hearing Impaired Listeners	8
Figure 3: Audio Source Connectors.....	8
Avoiding Hum in the Audio (as a Result of a Ground Loop)	9
Figure 4: Connecting to a Balance/Unbalanced Line.....	9
Installing the ANT 025 Whip Antenna	9
Figure 5: Installing the ANT 025 Antenna (rear view).....	9
Connecting the T45 to other Devices	10
Figure 6: T45 Typical Connections.....	10
Controls & Features	11
Figure 7: PPA T45 Front View.....	11
Power Button	11
OLED Display	11
Audio Input Level Indicator	11
Input Overload Indication	11
RF Indicator (On Air)	11
Hot Buttons / Menu Controls	11
Headphone Jack	12
Main Info Screen and Screen Navigation	12
Lock/Unlock Settings 	12
Figure 8: Main Info Screen.....	12
Figure 9: Navigating the Menu.....	12
Quick Setup Instructions	13
Front Screen Menu Tree (Quick Reference)	14
Figure 10: Front-screen Menu Tree.....	14
Figure 11: Front-screen Menu Tree (continued).....	15
Figure 12: Front-screen Menu Tree (continued).....	16
Front Screen Menu Tree (Detailed Instructions)	16
1. AUDIO SETTINGS	16
1a. Audio Presets.....	16
Figure 13: Audio Preset Configuration Table.....	16
High Pass Filter.....	17
Low Pass Filter.....	17

Compression.....	17
1b. Audio Source.....	18
1c. Audio Input Gain.....	19
1d. Headphone Source.....	19
1e. Headphone Volume.....	19
2. RF SETTINGS.....	20
2a. Channel (or Frequency).....	20
Figure 14: Channel/Frequency Selection Chart.....	20
2b. RF Output Power.....	20
2c. RF Time-Out.....	21
3. PREFERENCES.....	21
3a. Display Mode.....	21
3b. Channel Mode.....	22
3c. Screen Time-Out.....	22
3d. User-Entered Transmitter Description.....	22
3e. Restore Defaults.....	23
4. ADD-ON MODULE (PPA T45NET only).....	24
4a. Status.....	24
4b. Network Settings.....	24
4c. Admin.....	25
Network Setup for Hard-wired Ethernet Devices (Laptop or Desktop PC).....	26
Figure 15: Williams Sound Device Discoverer Tool (optional).....	27
Network Setup for Wireless Devices (iPad, Android Tablet, or Smart Phone).....	28
Figure 16: Williams Sound Device Discoverer Tool.....	28
Web Control Interface.....	30
Figure 17: Main Login Page and Ethernet Communication Status.....	30
Figure 18: Home Page.....	31
Figure 19: Audio Settings Page.....	32
Figure 20: RF Settings Page.....	33
Figure 21: Network Settings Page.....	34
Figure 22: Administration Page.....	34
Receiver Safety Information.....	35
Recycling Instructions.....	35
Wideband FM Receivers (Model Selection is Optional).....	36
Receiver Model PPA R38.....	36
Figure 23: PPA R38 Controls and Display.....	36
Operating the receiver.....	36
Wideband FM Receivers (continued).....	37
Receiver Model PPA R37.....	37

Operating the PPA R37 Receiver	37
Figure 25: Battery and channel selections.....	37
Figure 24: PPA R37 controls.....	37
LED Flash Codes	37
Receiver Model PPA R35-8	38
Operating the PPA R35-8 Receiver	38
Connecting Earphones/Headphones	38
Battery Installation (All Receiver Models)	38
Figure 26: PPA R35-8 controls.....	38
Belt Clip Installation (All Receiver Models)	39
Earpad Cleaning for Earphones and Headphones	39
Figure 27: Belt Clip Installation and Removal.....	39
Suggestions For Receiver Management	40
Receiver Battery Information (All Receiver Models)	40
Battery Charger Information.....	40
Troubleshooting	41
The T45 “RF” (On Air) Indicator is not on.....	41
No Audio heard in Phones jack.....	41
Noise or Distortion in the Audio.....	41
Noise in audio “grows” when program is silent.....	41
Reception difficulties.....	41
No Reception.....	41
Insufficient range, good reception near transmitter, poor at a distance.....	41
Users must turn receiver volume controls way up (to 4 or 5) to get enough volume.....	42
Users complain of too much noise during soft audio. Dynamic range of music reduced too greatly.....	42
Buzz in other equipment when transmitter is on or off.....	42
Buzz or other noise in equipment only when transmitter is on.....	42
Remote Control is not working over the hardwired Ethernet network.....	43
Remote Control is not working over Wi-Fi.....	44
System Specifications PPA T45, PPA T45NET Transmitters	45
System Specifications PPA T45, PPA T45NET Transmitters (continued)	46
System Specifications PPA R38 Receiver	47
System Specifications PPA R35-8 Receiver	48
System Specifications PPA R37 Receiver	49
Lifetime PLUS Limited Warranty	50

This page intentionally left blank

System Connection Overview

The PPA T45 is an FM Wide-Band transmitter operating in the 72-76MHz bandwidth. Compatible Williams Sound receivers include PPA R38, PPA R37, PPA R35-8 body packs and the PPA R1600 remote speaker.

Developed for hearing assistance in places of public access, the PPA T45 is designed for those who need help overcoming background noise, reverberation, or distance from the sound source. It includes a complete audio processor optimized for the needs of hearing impaired persons and is easily integrated with your existing sound system. The PPA T45 can also be used with a microphone as a stand-alone system.

Your PPA T45 transmitter operates just like an FM radio station. The transmitter takes audio directly from a microphone or sound system. This audio is then broadcast over an FM radio signal. FM radios can be worn by listeners or an AC powered amplified speaker with built in receiver can be utilized as needed. The broadcast can be received up to 1000 ft from the transmitter *. This allows listeners to sit anywhere in the area and listen to the broadcast at the volume level they need without disturbing others around them.

Two models are available - one with Ethernet control (PPA T45NET) and one without Ethernet control (PPA T45). Ethernet control allows the transmitter settings to be changed over a network with hard-wired or wireless devices (Figure 1).

*Range is dependent on the environment.

Figure 1: Typical System Example

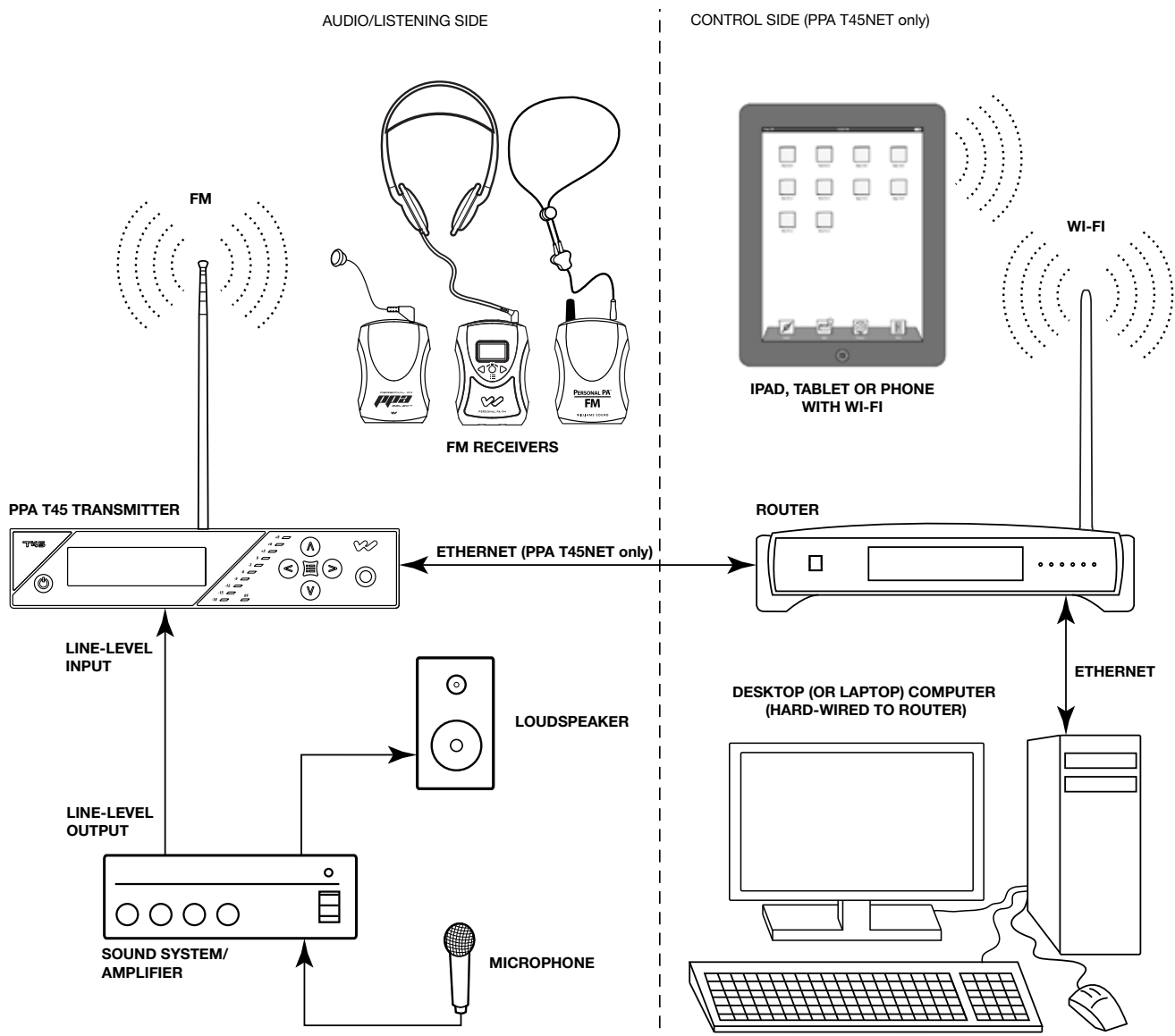

Wiring and Connections

Figure 2: PPA T45NET Rear View

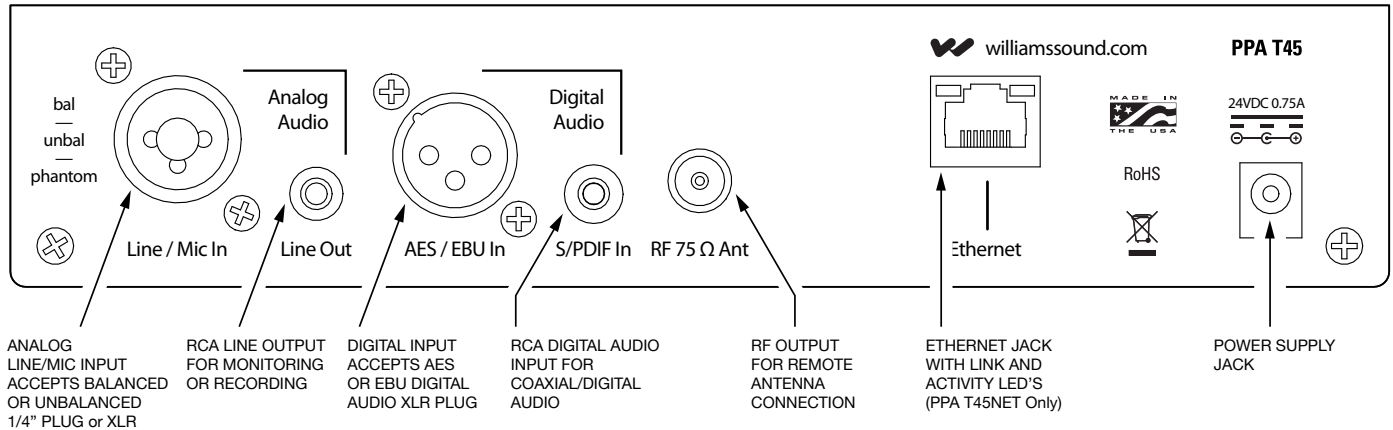

Power Supply Connection

Connect the TFP 048 power supply to the Power Supply Jack located on the rear of the PPA T45 transmitter (Figure 2).

Ethernet Connection

If connecting to a network, or connecting directly to a PC, a Standard **or** Crossover Ethernet cable may be used. The PPA T45NET auto-senses the connection and configures itself for the Ethernet cable type being used.

Audio Source Connections

The T45 transmitter will accept the following audio sources:

1. Balanced Microphone on a 3-pin (XLR) connector without phantom power.
2. Balanced Microphone with 12 volt phantom power (DIN 45596) on a 3-pin (XLR) connector.
3. Balanced/Unbalanced microphone with or without phantom power on 1/4 inch (TRS) jack
4. Balanced/Unbalanced Line on a 3-pin (XLR) connector.
5. Balanced/Unbalanced Line on 1/4 inch (TRS) jack.
6. Digital Audio (AES/EBU) on a 3-pin (XLR) connector.
7. Digital Audio (S/PDIF) on an RCA jack.



WARNING:

The T45 is not designed to accept 70 volt speaker signals! This may result in damage to your system. The sound source should come directly from the system mixer or digital source as a low-level or unprocessed signal.

IMPORTANT: When a suitable audio source has been determined, you **MUST** configure the audio source in the menu of the T45 before plugging that source in.

NOTE: FCC regulations, section 15.21, requires the user to comply with the rules of transmitter operation. Any changes or modifications made by the user not expressly approved for compliance may result in the loss of all privileges and authority to operate the equipment.

Figure 3: Audio Source Connectors

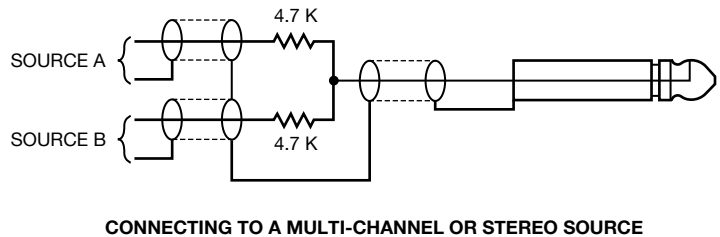
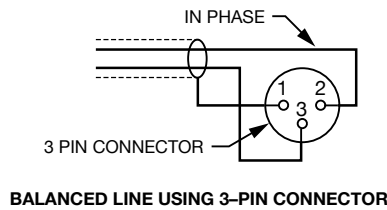
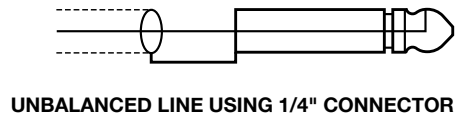
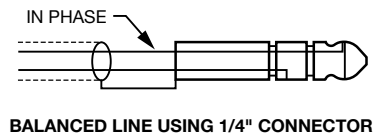
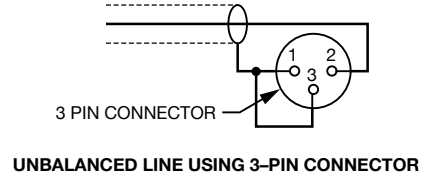
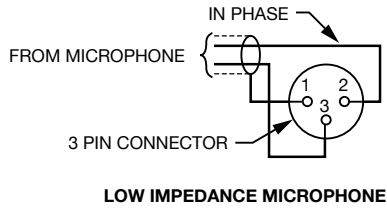

Multi-Channel Sources

By constructing a simple resistive mixer, stereo (or 3 channel) sources can be connected to the T45. Additional channels can be accommodated by adding a resistor for each source. Necessary resistors can be obtained from Williams Sound (Part Number RFC 472) or from any local electronics parts supplier. See Figure 3.

Selecting an Audio source Appropriate for Hearing Impaired Listeners

If the T45 is going to be used specifically for the accommodation of hearing impaired listeners, we recommend following these general guidelines:

The PPA T45 transmits audio with excellent fidelity. Therefore, the audio source signal should be of the highest audio quality and not subject to a compressor, limiter, reverberation, or other signal processing equipment. The T45 has a very effective DSP audio processor. If compression is desired in the audio, refer to the "Compression" section under "Audio Settings - 1a. Audio Presets" for available settings. Excessive compression is not helpful to the hearing impaired and can contribute to excessive noise in the receiver outputs.

The T45 audio source signal is usually connected to a mixer's "line output" signal which is behind the mixer's parametric equalizers but ahead of any equalization used for house loudspeakers.

If audio delay is available for use in large auditoriums, it's usually best to use it. Because radio signals travel faster than sound, delaying the transmitted audio so that an average listener (in the middle of the listening area) hears the transmitted audio a few milliseconds after audio from the main sound reinforcement system speaker is helpful. This will also help audience members who lip read.

Avoiding Hum in the Audio (as a Result of a Ground Loop)

A hum created by a ground loop can often be eliminated by connecting a capacitor in series with the audio line shield to the transmitter's ground. This method also maintains good RF shielding. Determining the effectiveness of this method for your installation usually requires some experimentation. Necessary capacitors can be obtained from Williams Sound or from any electronic parts supplier. See Figure 4.

Figure 4: Connecting to a Balance/Unbalanced Line

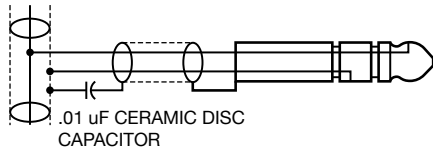

BREAKING A GROUND LOOP WHEN CONNECTING TO A UNBALANCED LINE

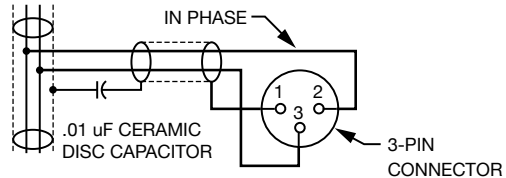

BREAKING A GROUND LOOP WHEN CONNECTING TO A BALANCED LINE

Installing the ANT 025 Whip Antenna

Gently thread the ANT 025 onto the stud recessed in the hole on the top of the transmitter. See Figure 5.

Figure 5: Installing the ANT 025 Antenna (rear view)

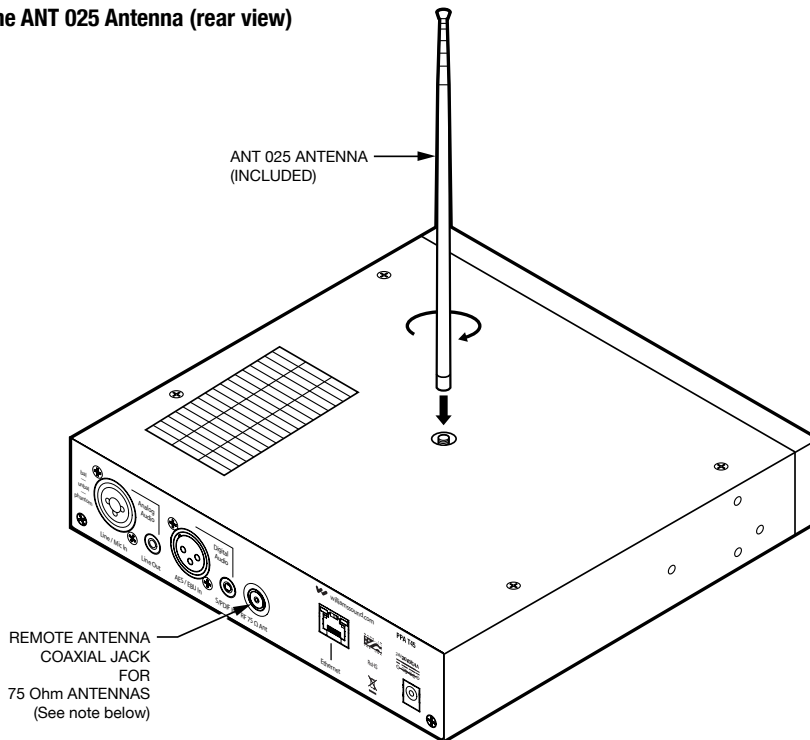

NOTE: If the T45 is going to be rack mounted, you will not be able to install the ANT 025 whip antenna. For rack mounting, consider installing a remote antenna like the ANT 005 or ANT 024 - these antennas require using the Remote Antenna Coaxial Jack (above) and a long length of terminated coaxial cable. Another option is to mount the antenna on the rack itself - consider the ANT 029 which includes a 1RU bracket and a 3ft terminated coaxial cable. For a full list of antenna options, please go to our website www.williamssound.com and view the Antenna Application Guide under "Products - Accessories - Antennas".

Connecting the T45 to other Devices

The **Analog LINE/MIC Input** jack can be used with standard pro audio electronics such as standard pro audio line level, condenser microphones up to 15v or an analog line output from a mixer. The combination jack accepts either XLR or 1/4" (TRS). This source **must be configured in the menu** before plugging the source into the jack.

The **RCA Audio Line Output** jack can be used for monitoring, recording, or routing processed audio to another sound system.

The **XLR Digital Line Input** can be used with the output of a digital mixer or digital audio source. The processors inside the T45 convert the digital bitstream into usable audio.

The **RCA S/PDIF Digital Line Input** jack can be used with a device that has an RCA Digital Audio Out (also referred to as "Coaxial Digital Audio" from consumer electronic devices). The processors inside the T45 convert the digital bitstream into usable audio.

The **Remote Antenna Connection** can be used to connect a remote antenna to the T45 when the whip antenna won't be used (as in the case of rack-mounting). See the Williams Sound Antenna Guide for a full range of antenna and mounting options (see Figure 5).

The **Ethernet Jack** (PPA T45NET only) can be used to connect the T45NET to either (1) a local network or (2) directly to a single computer. Both options can use either a *standard Ethernet cable* or a *crossover cable*. A crossover cable can be used, but is *not required* to connect the T45 directly to a computer, because an internal MUX senses the device that is connected and crosses the pins automatically.

Figure 6: T45 Typical Connections

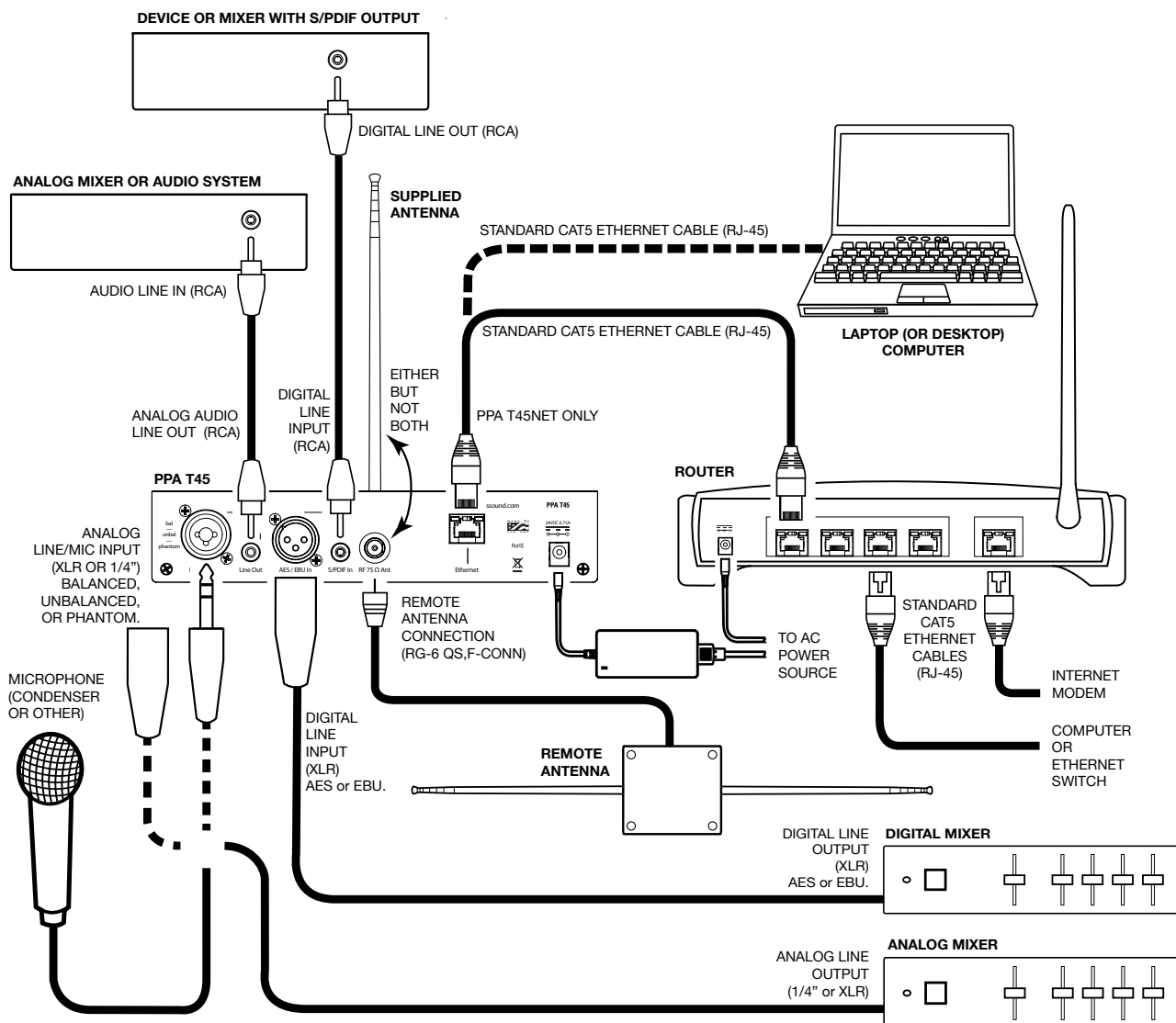

Controls & Features

Figure 7: PPA T45 Front View

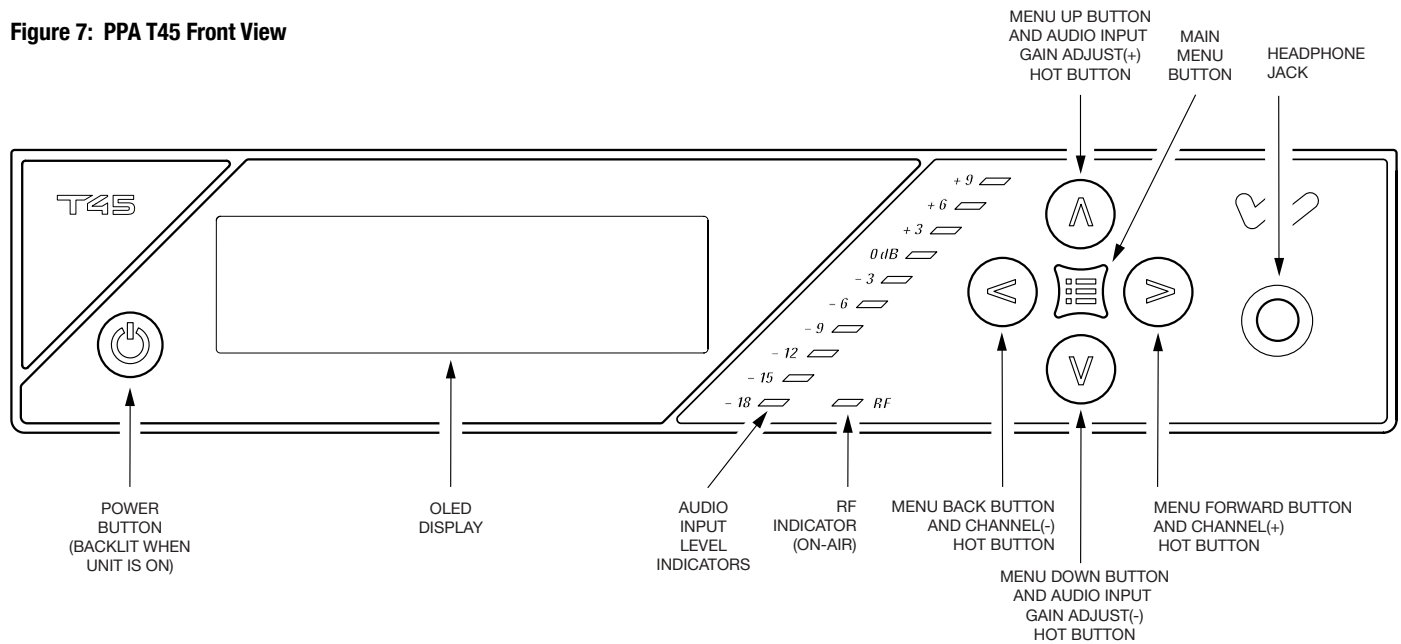

Power Button

Latching push-button switch turns the transmitter on or off. The desktop power supply provides power to the unit at all times. (Figure 7)

OLED Display

This shows current operation settings and is also used with the menu control buttons for configuring the T45. Each time the power of the unit is turned on, the OLED Display shows a “Williams Sound” start-up screen (Figure 8). After seven seconds, the “RF” (On-Air) LED will illuminate and the default Main Info Screen screen will be displayed. The T45 is now fully operational. If the “RF” (On-Air) indicator does not illuminate, check the RF settings to make sure RF is not set to “RF OFF”. Make sure the power supply is properly installed, and the power button is in the “on” position. (Figure 7)

(NOTE: If the transmitter is not fully functional, and the internal tests fail, the transmitter will attempt to auto-recover by rebooting itself.)

Audio Input Level Indicator

The bar graph indicator shows audio level in 3dB steps at the input of the audio level processing circuit. The indicator is peak responding and is calibrated so that optimum level is reached when the 0dB LED lights up often and the +9dB only lights occasionally. Use the Audio Level settings in the menu to set the audio levels. (Figure 7)

Input Overload Indication

The OLED Display shows an overload warning screen each time the audio signal exceeds the capacity of the input circuit. Either (1) the source of the audio coming in to the T45 needs to be adjusted to correct this or (2) the Audio Input Gain needs to be adjusted. (Figure 7)

RF Indicator (On Air)

Indicates when radio frequency is transmitting. (Figure 7)

Hot Buttons / Menu Controls

- While the transmitter is displaying the *Main Info Screen* (Figure 8), the **Up “^”** and **Down “v”** buttons adjust the **Audio Input Gain**; while the **Left “<”** and **Right “>”** buttons change the **Channel**. This immediate adjustment capability is referred to as “**Hot Buttons**”.
- The **Menu** button is a **Enter/Exit menu** function only. It does not “select” anything within the menu. It allows the user to quickly return to the Main Info Screen from any place in the menu.

- While the transmitter is displaying the *Menu* on the screen:
 - The **Up** “^” button *navigates upward* in the menu or *changes* a setting. (Figure 9)
 - The **Down** “v” button *navigates downward* in the menu or *changes* a setting. (Figure 9)
 - The **Left** “<” button *backs out of the menu* one step at a time (see the menu tree). (Figure 9)
 - The **Right** “>” button *navigates forward* in the menu (see the menu tree) or selects a setting. When entering a Description, IP Address, or Subnet Mask for the Transmitter (see the menu tree) this button advances to the next character. (Figure 9)

Headphone Jack

A headset plugged into the headphone jack allows monitoring either the audio input before it is processed and transmitted by the T45 (Analog Sources only) or the T45 audio output after it gets processed. By default, the headphone jack audio is set for “TRANSMITTED AUDIO”. The Menu also allows the listener to select “INPUT AUDIO”. When monitoring a digital input, the only option available will be “TRANSMITTED AUDIO”, since the digital source cannot be listened to directly, it must be converted to analog audio first (Figure 7).

Main Info Screen and Screen Navigation

The Main Info Screen will show the following information: Operating Frequency/Channel, Device Description (if entered, otherwise blank), RF Power Level, Network Link (PPA T45NET only), Audio Source, Audio Application Preset, Audio Input Gain Setting, and Locked . The lock symbol indicates that the front panel buttons are locked, which prevents any functions from being accidentally changed. If the front panel (menu) has been locked the display will show the lock symbol, otherwise this area will be blank. (Figure 8)

If the T45NET is connected to a network or a PC, the network link will be displayed as shown in Figure 8. If the T45NET is not connected, the network symbol will have an “X” through it (not shown).

Lock/Unlock Settings

To lock or unlock the front panel buttons, press and hold the **Left** “<” and **Right** “>” buttons together on the front of the T45 for 3 seconds. Three dashes will appear in the area where the lock symbol is shown (below), then disappear. When the last dash has disappeared, a pop-up screen will appear indicating the settings have been locked (or unlocked) and the buttons can be released.

Figure 8: Main Info Screen

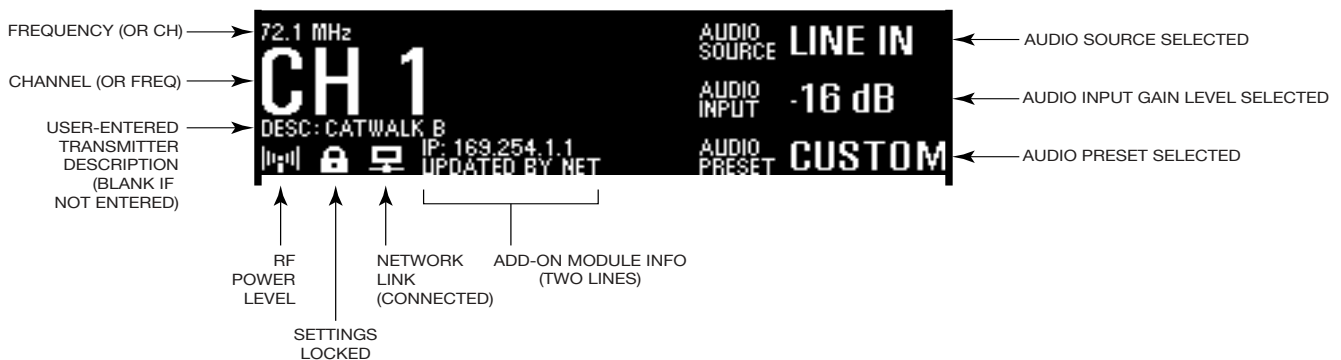

While navigating through the menu, caret symbols (<, >, ^, v) will show up, indicating that parts of the menu exist “off-screen” to the left, right, above or below. (Figure 9)

Figure 9: Navigating the Menu

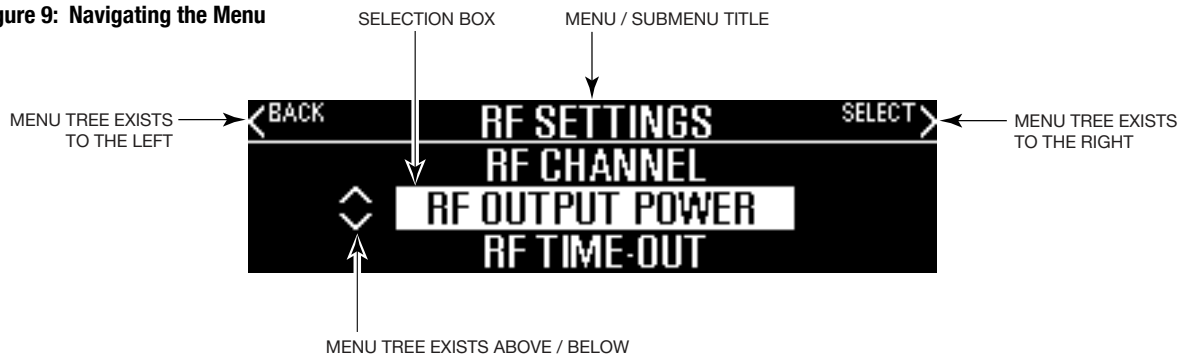

Quick Setup Instructions

1. Position the PPA T45 transmitter near the sound system or mixer from which it will receive audio. It should be free from metallic objects that might interfere with the antenna signal.
2. If the transmitter is free-standing (not rack-mounted), install the ANT 025 whip antenna. Gently thread the ANT 025 onto the stud recessed in the hole on the top of the transmitter (Figure 2) and extend it all the way. The transmitter can be rack-mounted (1RU) with the optional RPK 005 Rack Mount Kit - in this case the whip antenna cannot be used; instead use the rear "RF 75Ω ANT" coaxial jack for remote antenna mounting with a coaxial cable (Figure 5).
3. Connect the power supply to the Power Supply connector (Figure 2, page 5) located on the back of the T45. Press in the power button on the front of the T45. The power button should light up, and the "RF" green LED indicator should illuminate. If not, go back and check the power connections.
4. Choose and configure the audio source. **The audio source must be configured in the menu before plugging the source into the jack.** Push the Menu button and push the ">" button once to display "AUDIO SOURCE" on the screen. Push the ">" button to access the audio sources. Using the "^" or "v" menu buttons (Figure 2), choose between "ANALOG LINE IN", "MIC", "PHANTOM MIC +12V", "DIGITAL AES/EBU", or "DIGITAL S/PDIF". When the desired audio source is displayed, it is active, so press the Menu button to exit the menu (Figure 7).
5. Push the power button to turn the unit off. (Figure 7)
6. Connect the audio source to the audio input jack on the rear of the T45 (the jack that was chosen in step 4). (Figures 2, 6)
7. Push the power button to turn the unit on. (Figure 7)
8. With the audio source playing, adjust the Audio Level on the T45 so that the green "0 dB" LED generally lights and the red "+9 dB" LED lights occasionally. To do this, use the Hot Buttons while on the main info screen. Press the "^" button to increase the audio level in 1.0 dB steps, or press the "v" button to decrease the audio level in 1.0 dB steps.
9. Select an Audio Preset. The T45 has three pre-configured Audio Presets to choose from: Hearing Assist, Music, and Voice. A Custom preset is also available. The performance of the T45 is optimized for each of the pre-configured Audio Presets. Using the menu and control buttons on the front of the T45 (Figure 7), push the Menu button, the display will change to show "Audio Settings". Use the forward ">" button to display "Audio Source" in the selection box. Push the down "v" button twice to show "Audio Presets". Now press the ">" button to display the list of Presets. Use the "^" and "v" buttons to alternate between "Hearing Assist", "Music", "Voice" and "Custom" selections. When the desired Audio Preset is displayed, it is active, so press the Menu button to exit the menu, or, if "Custom" is desired, push the ">" button to enter the custom settings.
10. Set the Transmitter Channel. The T45 is shipped from the factory with the channel/frequency set to Ch.1 (72.1 MHz). To change the channel/frequency, while on the main info screen, use the hot buttons "<" and ">" to change channels. (Figure 7)
11. Listen with an FM receiver (see compatible Williams Sound receivers towards the back of this manual). Install the batteries, plug in the earphone, turn on the receiver, choose the correct channel and walk around the listening area. The signal should be clear and quite loud when the volume is turned up.
12. (T45NET only) Connect a CAT5e Ethernet cable from your local area network, wi-fi router, or PC to the connector on the T45NET labelled "Ethernet".
13. (T45NET only) Once the T45 detects an active network is present, the "X" will disappear from the computer icon on the main info screen, indicating that it has connected to the network. The main info screen will display the text "IP:\", where the last character "\" will spin, while the T45 is acquiring a DHCP address. Once acquired, (usually takes less than a minute), the T45's IP address will be displayed in the "Add-on module" part of the Main Info Screen. (Figure 8)
14. (T45NET only) Open a web browser (i.e. Internet Explorer, Mozilla Firefox, Google Chrome, Safari, etc.) on a computer or mobile device that is also connected to the same local network as the T45.
15. (T45NET only) In the address bar of the browser, type in the IP address that is shown on the front of the T45NET's main info screen, and push the enter key on the keyboard. (Note: it is not necessary to type "http://" or "www." preceding the IP address, just the characters following "IP:", including the periods)
16. (T45NET only) The browser will open the T45NET's web page, displaying a "Log In" button (Figure 17). Click the log-in button and enter the user name "admin" and the default password "admin".
17. (T45NET only) The web browser will now show the T45NET's Home Page (Figure 18), which shows the current T45NET status info. The tabs at the top navigate to different pages that allow adjustment of the T45NET's settings.

IMPORTANT: The FM receiver being used will need to be on the same channel/frequency as the T45 transmitter.

Front Screen Menu Tree (Quick Reference)

The default "MAIN INFO SCREEN" shows important overall system settings (see Figure 8). The menu screens are used to configure the T45 (Figures 10,11,12). To enter the menu, push the "Menu" button. Then use the Forward ">" and Down "v" buttons to navigate deeper into the menu. When a setting is reached, the display will change to show an up and down caret ("^","v") around the setting. Use the Up "^" and Down "v" buttons to change the setting. Note that nearly all settings change *live*, they do not need to be "selected" with another button. The setting displayed in the *selection box* is the one that is active. After a period with no button presses, the OLED will return to the Main Info Screen, then display a screen saver, then go blank. When the display is blank, and the "RF" indicator is lit, the transmitter is still broadcasting. If audio is present the audio input level LED's will pulse to the level of the audio. Pressing any button will restore the Main Info Screen and restart the screensaver/auto-off timer.

Figure 10: Front-screen Menu Tree

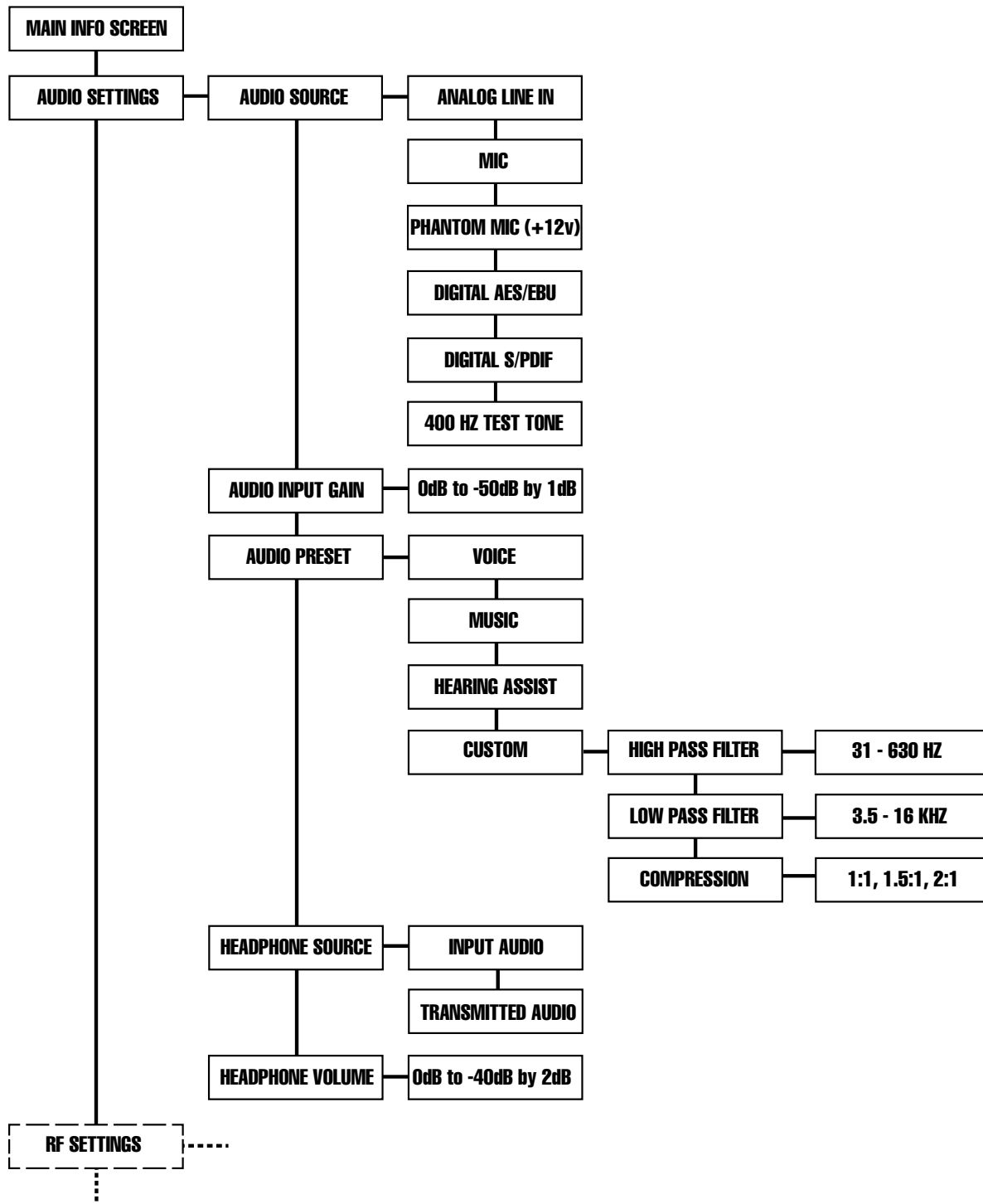

Figure 11: Front-screen Menu Tree (continued)

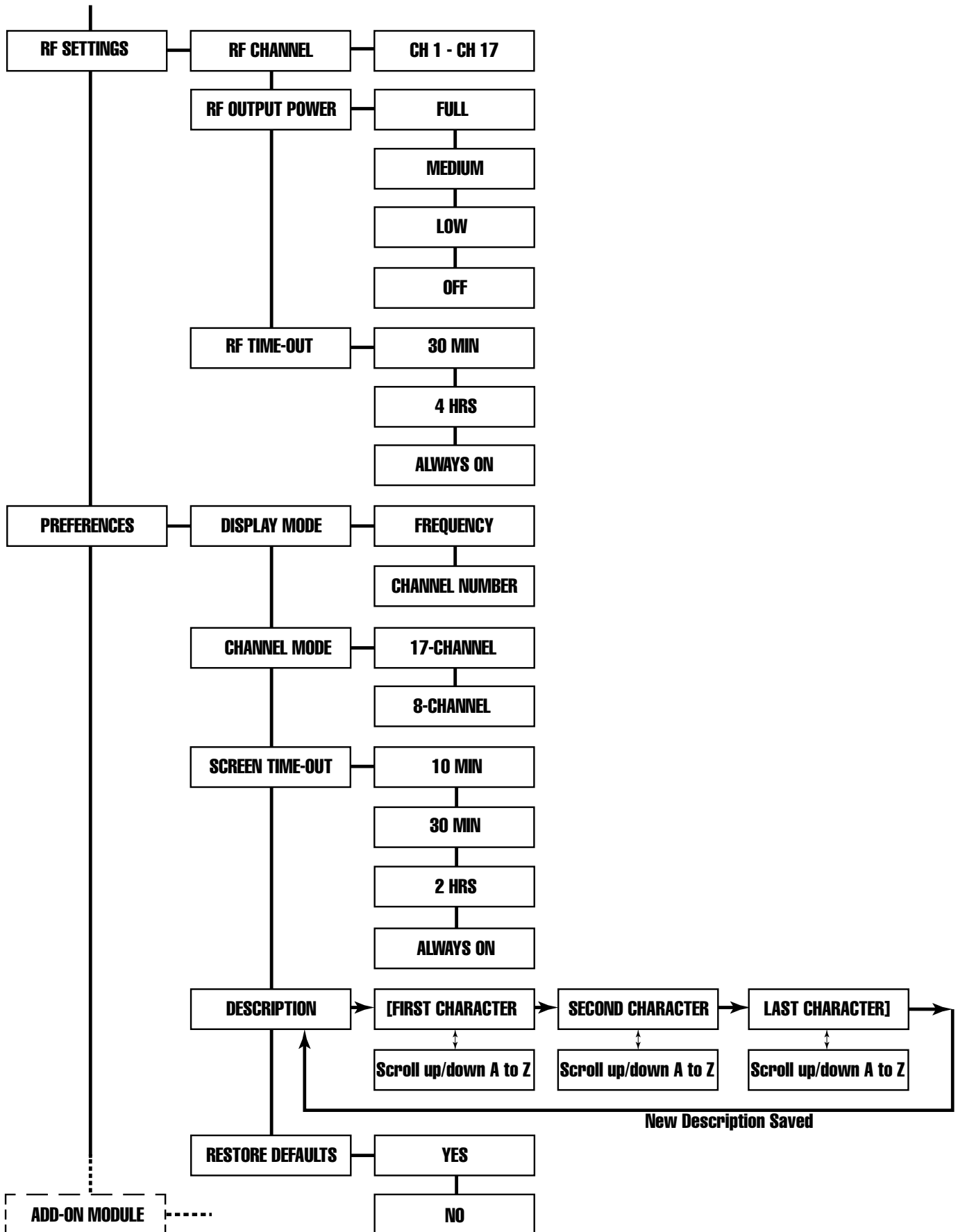
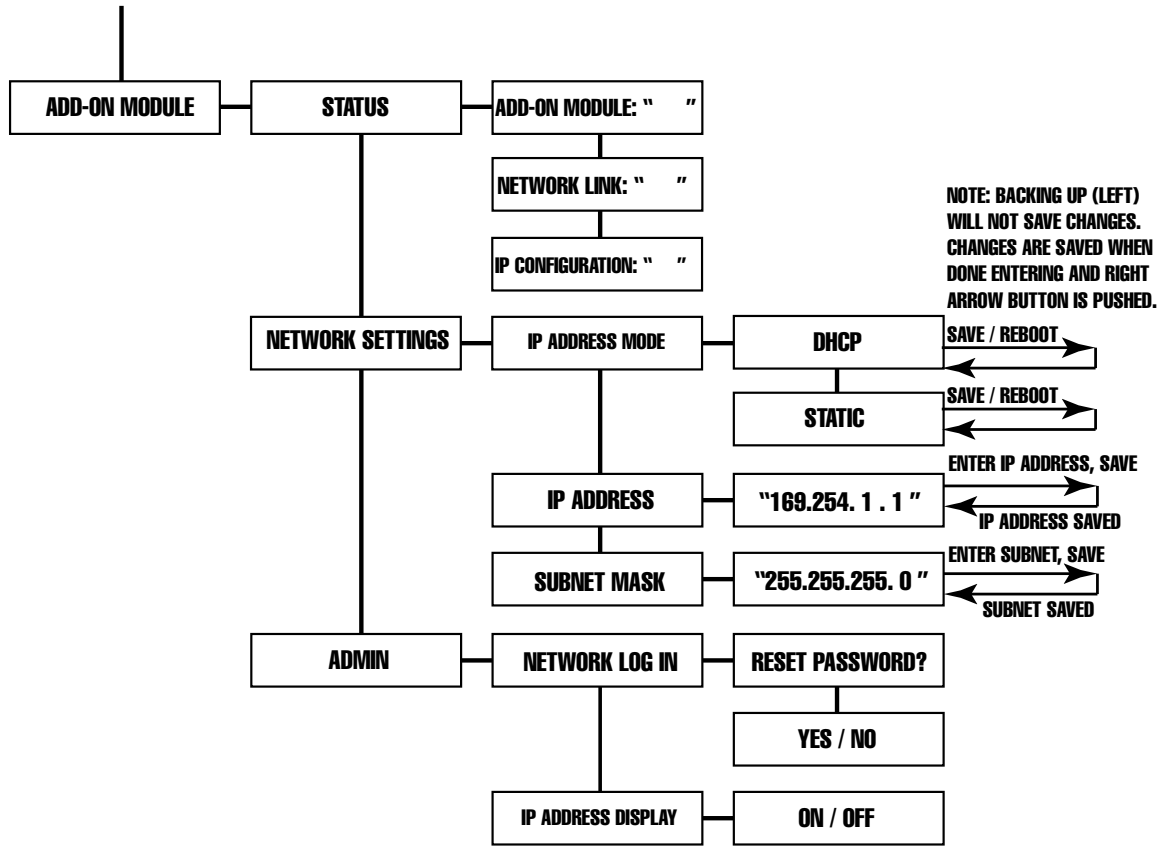

Figure 12: Front-screen Menu Tree (continued)

The Add-on module applies to the PPA T45**NET** model only. In the PPA T45 model, the first screen in the “Add-On Module” menu will display “No Module Detected”.



Front Screen Menu Tree (Detailed Instructions)

1. AUDIO SETTINGS

The Audio Settings provide the ability to change the audio characteristics for different listening applications, choose the input source, adjust the input level, choose the audio to be monitored by the headphone, and adjust the headphone volume.

1a. Audio Presets

The Audio Presets allow the user to quickly and easily configure the T45 for common applications. In some cases, the Audio Presets may be the only setup needed for properly configuring the T45 transmitter.

There are three pre-configured and one custom Audio Preset to choose from: **Hearing Assist, Music, Voice and Custom.** When one of these selections is made, the performance of the T45 is immediately optimized for the needs of that application (an adjustment is automatically made to the Low-Pass Filter, High Pass Filter, and Compression). Refer to the chart below (Figure 13) for a comparison of the Audio Preset configurations.

Figure 13: Audio Preset Configuration Table

RF Output = Full Power

Parameters:	Hearing Assist	Music	Voice
Low Pass Filter	8.0 kHz	16 kHz	6.3 kHz
High Pass Filter	500 Hz	31 Hz	125 Hz
Compression Ratio	2:1	1:1	1:1



IMPORTANT: Listen to the transmitted audio through the headphone jack, especially when deciding on an appropriate high pass filter. This is a good way to ensure the listening audience is going to receive the highest audio quality.

By default, the T45 is shipped in the **Music** mode. For music, concerts, and other applications where the highest audio quality is desirable, **Music** is the recommended mode of operation. For hearing assistance applications, or applications where the message is critical for listening, **Hearing Assist** is the recommended mode of operation. For speaking and other voice applications, **Voice** is the preferred mode of operation.

If the three preset configurations do not meet the needs of the venue, the **Custom** audio preset can be used. The custom preset allows the user to adjust the High-Pass Filter cutoff frequency, Low-Pass Filter cutoff frequency, and choose the Compression Ratio. If the audio preset is changed from Custom to Music, Hearing Assist, or Voice, the Custom settings are overwritten.

High Pass Filter

A High Pass Filter cuts off low frequencies and lets high frequencies “pass” through. The frequency chosen is the point where the cutoff takes effect. The high pass filter will help to remove low frequency “noise” from the transmitted audio signal, such as room noise, a line hum, or breath accents picked up from an improperly installed microphone.

Low Pass Filter

A Low Pass Filter cuts off high frequencies and lets low frequencies “pass” through. The frequency chosen is the point where the cutoff takes effect. The low pass filter will help to remove high frequency “noise” from the transmitted audio signal, such as hiss in the audio line as a result of room noise, sharp speech sounds, or other uncomfortable high frequency sounds.

Compression

Compression reduces the dynamic range of the audio (volume difference between loud and soft sounds). It is typically used for voice and hearing assistance applications - for a listener who has difficulty hearing the quiet sounds of an audio broadcast, compression boosts the quiet sounds to louder listening levels. For listening to music programs, concerts, etc., lower compression ratios or no compression is generally used.

The T45 has three selectable modes of compression: 1:1 (compression off), 1.5:1 (low compression) or 2:1 (high compression). For applications such as music and voice, where high audio quality is desirable, 1:1 is the recommended mode of operation. For hearing assistance or applications where the transmitted message is critical for listening, 1.5:1 or 2:1 is recommended.

NOTE: The T45 is shipped from the factory at a 1:1 compression ratio (no compression).

NOTE: The manager of the T45 needs to take care in using compression, because some hearing impaired people cannot tolerate as loud of a sound as those with normal hearing.

To select a preconfigured Audio Preset:

1. Press the Menu button. The display will show “AUDIO SETTINGS” in the selection box.
2. Press the “>” button to display “AUDIO SOURCE” in the selection box.
3. Press the “v” button twice to display “AUDIO PRESET” in the selection box.
4. Press the “>” button to access the Audio Presets. The currently selected preset is shown in the selection box.
5. Press the “^” or “v” menu buttons to select either “VOICE”, “MUSIC”, “HEARING ASSIST” or “CUSTOM” audio. Note that the setting changes *live*, it does not need to be “selected” with another button. The setting displayed in the selection box is the one that is active. Refer to the Configuration Table in Figure 11 for details about each preset.
6. When the desired Audio Preset is selected, press the Menu button to exit the menu and return to the main info screen.

No additional action is necessary. If no buttons are pressed, after 5 minutes the OLED will return to the Main Info Screen, then after another 10 minutes show a screen saver, then go blank (the time between the screen saver and blank screen is adjustable). When the display is blank, and the “RF” indicator is lit, the transmitter is broadcasting. If audio is present the audio input level LED’s will pulse with the level of the audio.

To set up the Custom Audio Preset:

1. Press the Menu button. The display will show "AUDIO SETTINGS" in the selection box.
2. Press the ">" button to display "AUDIO SOURCE" in the selection box.
3. Press the "v" button twice to display "AUDIO PRESET" in the selection box.
4. Press the ">" button to access the Audio Presets. The current preset will be shown in the selection box.
5. Press the "v" button until "CUSTOM" is displayed in the selection box.
6. Press the ">" button to access the Custom Audio Preset. The current High Pass Filter setting will be displayed in the selection box.
7. Press the "^" or "v" button until the desired High Pass Cutoff Frequency is shown in the selection box. Press the "^" menu button to decrease the cutoff frequency, or the "v" button to increase the cutoff frequency. Each time the "^" or "v" button is pressed, the cutoff frequency will be changed by 1/2 octave. This can be repeated until the cutoff frequency reaches the minimum of 31 Hz, or maximum of 630 Hz. Note that the setting changes *live*, it does not need to be "selected" with another button. The setting displayed in the selection box is the one that is active.
8. Press the ">" button to access the Compression Setting.
9. Press the "^" or "v" button until the desired Compression Ratio is shown in the selection box. Press the "^" or "v" button to change the compression ratio to 1:1, 1.5:1 or 2:1. Note that the setting changes *live*, it does not need to be "selected" with another button. The setting displayed in the selection box is the one that is active.
10. Press the ">" button to access the Low Pass Filter Setting.
11. Press the "^" or "v" button until the desired Low Pass Cutoff Frequency is shown in the selection box. Press the "^" button to increase the cutoff frequency, or the "v" menu button to decrease the cutoff frequency. Each time the "^" or "v" button is pressed, the cutoff frequency will be changed by 1/2 octave. This can be repeated until the cutoff frequency reaches the minimum at 3.5 KHz, or maximum at 16 KHz. Note that the setting changes *live*, it does not need to be "selected" with another button. The setting displayed in the selection box is the one that is active.
12. When the desired settings have been changed, press the Menu button to exit the menu and return to the Main Info Screen.

1b. Audio Source

The Audio Source menu is used to configure the T45 for the audio source jack and type of source that will be used. The audio source ***must be configured in the menu*** before plugging the source into the jack. The transmitter will accept the following audio sources:

- Balanced Microphone on a 3-pin (XLR) connector **without** phantom power.
- Balanced Microphone on a 3-pin (XLR) connector **with** 12 volt phantom power.
- Balanced/Unbalanced microphone on 1/4 inch (TRS) jack **without** phantom power.
- Balanced/Unbalanced microphone on 1/4 inch (TRS) jack **with** 12 volt phantom power.
- Balanced/Unbalanced Line on a 3-pin (XLR) connector.
- Balanced/Unbalanced Line on 1/4 inch (TRS) jack.
- Digital Audio (AES/EBU) on a 3-pin (XLR) connector (44.1 or 48 KHz sample rate).
- Digital Audio (S/PDIF) on an RCA jack (44.1 or 48 KHz sample rate).

The Audio Source menu has five possible selections to choose from: Analog Line In, Mic, Phantom Mic +12V, Digital AES/EBU, or Digital S/PDIF.

To select the audio source:

1. Press the Menu button. The display will show "AUDIO SETTINGS" in the selection box.
2. Press the ">" button to display "AUDIO SOURCE" in the selection box.
3. Press the ">" button to access the Audio Sources. The current audio source will be shown in the selection box.
4. Press the "^" or "v" button until the desired audio source is displayed in the selection box.
5. When the desired audio source has been selected, press the Menu button to exit the menu and return to the Main Info Screen. At this point you can plug the source into the jack on the back of the T45.

1c. Audio Input Gain

The Audio Input Gain adjusts the incoming audio level into the T45. This adjustment affects analog and digital audio. Changes to the input level will affect the level indicated by the front panel LED's when audio is present.

To adjust the audio input level:

1. Press the Menu button. The display will show "AUDIO SETTINGS" in the selection box.
2. Press the ">" button to display "AUDIO SOURCE" on the screen.
3. Press the "v" button repeatedly until "AUDIO INPUT GAIN" is displayed in the selection box.
4. Press the ">" button to access the Input Level. The currently selected level will be shown in the selection box.
5. With the audio source playing, adjust the Input Level so that the green "0 dB" LED generally lights and the red "+9 dB" LED lights occasionally. Press the "^" or "v" menu buttons to adjust the level from 0dB to -50dB in steps of 1dB. Note that the settings change *live*, they do not need to be "selected" with another button. The setting displayed in the selection box is the one that is active.
6. When the desired audio level is reached, press the Menu button to exit the menu and return to the main info screen.

1d. Headphone Source

The Headphone Source setting allows either input audio or transmitted audio to be monitored through the headphone jack.

To change the headphone source:

1. Press the Menu button. The display will show "AUDIO SETTINGS" in the selection box.
2. Press the ">" button to display "AUDIO SOURCE" on the screen.
3. Press the "v" button repeatedly until "HEADPHONE SOURCE" is displayed in the selection box.
4. Press the ">" button to access the Headphone Sources. The currently selected source will be shown in the selection box.
5. Press the "^" or "v" menu buttons to select either "INPUT" or "TRANSMITTED" audio. If a Digital Source is being transmitted, the only selection possible for the headphone is transmitted audio, because digital audio has to be processed before it can be listened to. Note that the setting changes *live*, it does not need to be "selected" with another button. The setting displayed in the selection box is the one that is active.
6. When the desired headphone source is selected, press the Menu button to exit the menu and return to the main info screen.

1e. Headphone Volume

The headphone volume level can be increased or decreased by using the "Headphone Volume" setting in the menu.

To adjust the headphone volume:

1. Press the Menu button. The display will show "AUDIO SETTINGS" in the selection box.
2. Press the ">" button to display "AUDIO SOURCE" in the selection box.
3. Press the "v" button repeatedly until "HEADPHONE VOLUME" is displayed in the selection box.
4. Press the ">" button to access the Headphone Volume setting. The current volume level will be shown in the selection box.
5. Press the "^" button to raise the volume in 2 dB steps, or the "v" button to lower the volume in 2 dB steps. Note that the volume changes *live*, it does not need to be "selected" with another button. The volume level displayed in the selection box is the one that is active.
6. When the desired headphone volume is reached, press the Menu button to exit the menu and return to the main info screen.

2. RF SETTINGS

The RF Settings provide the ability to change the broadcasting Channel, RF Output Power level, and the RF time-out delay.

2a. Channel (or Frequency)

The Channel setting allows the channel number or corresponding frequency to be selected. Note: this depends on what display mode the transmitter is in (see Step 3a). If the transmitter is in *channel* display mode, channels 1-17 or 1-8 can be selected depending on channel mode. If the transmitter is in *frequency* display mode, frequencies can be selected from 72.1 MHz to 75.9 MHz.

To change the channel/frequency:

1. Press the Menu button. The display will show "AUDIO SETTINGS" in the selection box.
2. Press the "v" button to display "RF SETTINGS".
3. Press the ">" button. "RF CHANNEL" will be displayed in the selection box.
4. Press the ">" button to access the Channels/Frequencies. The currently selected Channel/Frequency will be shown in the selection box.
5. Press the "^" or "v" buttons to change the channel/frequency. Note that the channel changes *live* (after a few seconds) - it does not need to be "selected" with another button. The channel/frequency displayed in the selection box is the one that is active. Refer to the chart below to choose the channel/frequency (Figure 14).
6. When the desired channel/frequency is selected, press the Menu button to exit the menu and return to the main info screen.

Note: The T45 is shipped from the factory with the frequency pre-set to Channel 1 (72.1 MHz).

Figure 14: Channel/Frequency Selection Chart

*			
T45 Ch	Letter	Freq (MHz)	R35-8 Ch
1	A	72.1	1
2	B	72.3	2
3	O	72.6	3
4	P	72.8	4
5	I	74.7	5
6	R	75.4	6
7	G	75.7	7
8	H	75.9	8
9	C	72.5	
10	K	72.2	
11	N	72.4	
12	D	72.7	
13	E	72.9	
14	J	75.3	
15	S	75.6	
16	T	75.8	
17	F	75.5	

*Up to 8 channels can be used simultaneously, and must be channels identified in this column. These channels correspond to the channels available on the R35-8 Receiver. These 8 channels have been verified to not interfere with each other. Outside sources of RF interference may limit how many of these channels may be used.

2b. RF Output Power

The T45 has three selectable transmitter power levels: FULL, MEDIUM (-10dB), LOW (-20 dB), and RF OFF. By default the T45 is set to "FULL" power mode. For general listening applications, "FULL" power is the preferred mode of operation. Full power provides the T45 with an operating range of up to 1000 ft (dependent on the environment).

For special listening applications, it may be desirable to reduce the overall operating range on the T45 if:

- 1) The audio transmission is to be contained to a "smaller" listening area;
- 2) The signal is too strong and it is overloading the receiver; or
- 3) Multiple T45 transmitters are used in adjacent classrooms where the FM signals overlap each other. In these cases, the power level on the T45 can be reduced to -10 dB or -20 dB. The RF output may be temporarily set to OFF (no power) to help troubleshoot interfering or overlapping RF signals.

To change the RF Output Power:

1. Press the Menu button. The display will show "AUDIO SETTINGS" in the selection box.
2. Press the "v" button to display "RF SETTINGS".
3. Press the ">" button. "RF CHANNEL" will be displayed in the selection box.
4. Press the "v" button to display "RF OUTPUT POWER".
5. Press the ">" button to access the RF Output Power settings. The currently selected power setting will be shown in the selection box.
6. Press the "^" or "v" buttons to change the power setting to "FULL", "MEDIUM", "LOW" or "RF OFF". Note that the setting changes *live*, it does not need to be "selected" with another button. The power level displayed in the selection box is the one that is active.
7. When the desired power level is selected, press the Menu button to exit the menu and return to the main info screen.

2c. RF Time-Out

The RF Time-Out setting determines how long the transmitter continues to transmit with no audio present (30 minutes, 4 hours, or Always On). Note that the RF Time-out delay and Screen Time-out delay are two *independent* events. After the RF time-out period occurs (with no audio input and no front panel button presses), the T45 will go into "sleep mode" to conserve power. During "sleep mode" the RF transmitter is completely shut off and the power switch light will fade from bright to dark to indicate the unit is in sleep mode.

To change the RF Time-Out:

1. Press the Menu button. The display will show "AUDIO SETTINGS" in the selection box.
2. Press the "v" button to display "RF SETTINGS" in the selection box.
3. Press the ">" button to display "RF CHANNEL" in the selection box.
4. Press the "v" repeatedly until "RF TIME-OUT" is displayed in the selection box.
5. Press the ">" button to access the RF Time-Out Setting. The currently selected time-out delay will be shown in the selection box.
6. Press the "^" or "v" buttons to change the RF Time-Out to "30 MINUTES", "4 HOURS", or "ALWAYS ON". Note that the setting changes *live*, it does not need to be "selected" with another button. The time-out delay displayed in the selection box is the one that is active.
7. When the desired time-out delay is selected, press the Menu button to exit the menu and return to the main info screen.

REMINDER: If the lock icon  is displayed on the default display, the menu screens are locked, and you will not be able to make changes from the front panel. To unlock the menu screens, refer to "Lock/Unlock Settings" under "Controls and Features".

3. PREFERENCES

The Preferences Settings provide the ability to change the Display Mode, Channel Mode, Screen Time-Out, User-Entered Transmitter Description, or Restore Factory Default Settings.

3a. Display Mode

The Display Mode setting determines (1) whether the channel or frequency is larger on the front display of the transmitter and (2) whether frequency or channel is displayed as the adjustment under the "RF CHANNEL" setting (see step 2a).

To change the Display Mode:

1. Press the Menu button. The display will show "AUDIO SETTINGS" in the selection box.
2. Press the "v" button repeatedly until "PREFERENCES" is displayed in the selection box.

3. Press the ">" button to access the Preferences.
4. Press the ">" button to access the "DISPLAY MODE" Setting. The currently selected display mode will be shown in the selection box.
5. Press the "^" or "v" buttons to change the Display Mode to "FREQUENCY" or "CHANNEL". Note that the setting changes *live*, it does not need to be "selected" with another button. The setting displayed in the selection box is the one that is active.
6. When the desired display mode is selected, press the Menu button to exit the menu and return to the main info screen.

3b. Channel Mode

The Channel Mode changes the range of selectable channels from all 17 channels to the 8 non-interfering channels. This comes into play when multiple transmitters are in use, serving multiple groups of listeners. 8-Channel mode allows the user to choose one of the 8 non-interfering channels for simultaneous transmission from multiple transmitters (i.e. Transmitter #1 on Channel 1, Transmitter #2 on Ch. 2, Transmitter #3 on Ch. 3, etc.) and prevents channels that would interfere from being available.

To change the Channel Mode:

1. Press the Menu button. The display will show "AUDIO SETTINGS" in the selection box.
2. Press the "v" button repeatedly until "PREFERENCES" is displayed in the selection box.
3. Press the ">" button to access the Preferences.
4. Press the "v" button until "CHANNEL MODE" is displayed in the selection box.
5. Press the ">" button to access the "CHANNEL MODE" Setting. The currently selected channel mode will be shown in the selection box.
6. Press the "^" or "v" buttons to change the Channel Mode from "17" to "8". Note that the setting changes *live*, it does not need to be "selected" with another button. The setting displayed in the selection box is the one that is active.
7. When the desired channel mode is selected, press the Menu button to exit the menu and return to the main info screen.

3c. Screen Time-Out

The Screen Time-Out setting determines how long the transmitter displays the screen saver. The transmitter waits for 10 minutes, after no activity (front panel button pushes), then displays the screen saver. After displaying the screen saver for the period of time set here, the transmitter display will shut off to conserve energy. Note that the Screen Time-out delay and RF Time-out delay are two *independent* events.

To change the Screen Time-Out:

1. Press the Menu button. The display will show "AUDIO SETTINGS" in the selection box.
2. Press the "v" button repeatedly until "PREFERENCES" is displayed in the selection box.
3. Press the ">" button to access the Preferences.
4. Press the "v" button until "SCREEN TIME-OUT" is displayed in the selection box.
5. Press the ">" button to access the "SCREEN TIME-OUT" Setting. The currently selected time period will be shown in the selection box.
6. Press the "^" or "v" buttons to change the Screen Time-Out setting to "10 MINUTES", "30 MINUTES" or "2 HRS". Note that the setting changes *live*, it does not need to be "selected" with another button. The setting displayed in the selection box is the one that is active.
7. When the desired screen time-out period is selected, press the Menu button to exit the menu and return to the main info screen.

3d. User-Entered Transmitter Description

The Description field allows the user to easily identify the transmitter. This typically comes into play when multiple transmitters are being used - to be able to distinguish one from another. The description appears on the front main info screen, and also on the web page (PPA T45NET only). In a rack, all the user has to do is activate the main info screen with a touch of any button on

the front, and the description is displayed as one of the fields on the main info screen. On the web interface (PPA T45NET only), the description appears on the Home page (Figure 18), making it easy to identify which transmitter the web page is controlling. Note that the default description “YOUR T45 NAME HERE” will appear if it has not changed. It’s also possible to enter all blanks in the description field, and then the description will be blank on the front display.

To change the Description:

1. Press the Menu button. The display will show “AUDIO SETTINGS” in the selection box.
2. Press the “v” button repeatedly until “PREFERENCES” is displayed in the selection box.
3. Press the “>” button to access the Preferences.
4. Press the “v” button repeatedly until “DESCRIPTION” is displayed in the selection box.
5. Press the “>” button to access the “DESCRIPTION” field. If a description has not been previously entered, the default text “YOUR T45 NAME HERE” will be displayed. If a description was previously entered, the character positions will already be filled with the current name. *Note: The default Description “YOUR T45 NAME HERE” will not show on the Main Info Screen unless it has been modified. When the Description is changed to all spaces, this will also prevent a description from appearing on the Main Info Screen.*
6. Press the “>” button to edit the description.
7. Press the “^” or “v” buttons to scroll through the characters.
8. Press the “>” button to advance to the next character position.
9. Repeat steps 7 and 8 until the last character is changed.
10. Press the “>” button to step through any remaining positions and press “>” once more to exit out of the description field.
11. The cursor is now highlighting “DONE EDITING”. If you want to save the description, push the “v” button (as shown). If you wish to clear all of the characters and start over, push the “>” button to highlight “CLEAR ALL” then push the “v” button to clear the characters. When finished editing, the screen will return to the description you just entered, so you can check it. At this point the description is active.
12. Press the Menu button to exit the menu and return to the main info screen.

3e. Restore Defaults

The Restore Defaults action will restore the transmitter to it’s original factory settings. This includes the Audio Preset, Input Source, Input Level, Headphone Source, RF Channel/Freq, RF Output Power, RF Time-Out, Display Mode, Channel Mode, Screen Time-Out, and Description. If the optional Ethernet Module is installed, it will also reset the IP address, Subnet Mask, IP Address Mode, and Web Page Security Password.

Note: Restoring defaults from the *front panel* will restore (reset) *all* settings. Restoring defaults from the web page will restore (reset) *all settings except* NET connectivity settings (IP Address, Subnet Mask, IP Address Mode, and Web Password). This maintains connectivity between the Web Page and the T45, after the T45 reboots.

To restore the transmitter to its factory default settings (from the front panel):

1. Press the Menu button. The display will show “AUDIO SETTINGS” in the selection box.
2. Press the “v” button repeatedly until “PREFERENCES” is displayed in the selection box.
3. Press the “>” button to access the Preferences.
4. Press the “v” button until “RESTORE DEFAULTS” is displayed in the selection box.
5. Press the “>” button to access the “RESTORE DEFAULTS” Setting. The currently selected choice “NO” will be shown in the selection box.
6. Press the “v” button to select “YES” (if desired).
7. If “YES” is desired, push the “>” button and verify the same selection on the “warning” screen to perform the reset. If “NO” is desired, push the “<” button to step back out of this setting, or press the Menu button to exit back to the Main Info Screen without resetting the transmitter.
8. If “YES” was selected in step 7, the transmitter is now resetting and re-booting. If “NO” was selected in step 7, press the Menu button to exit the menu and return to the main info screen.

4. ADD-ON MODULE (PPA T45NET only)

The Add-On Module Settings show up in the menu only if the optional ethernet module is installed (PPA T45NET only). This menu provides the ability to view the Status of the add-on module, choose the IP Address Mode (Static or and Dynamic IP Addressing), change the IP Address and Subnet Mask, set/change the Security Password and choose whether or not to display the IP Address on the front display.

4a. Status

The Status screen shows which module is installed (PPA T45NET has the "NETWORK CONTROL 251" board), if a network link has been established, and the IP Configuration (Static, DHCP Host, or DHCP Client).

To view the Status:

1. Press the Menu button. The display will show "AUDIO SETTINGS" in the selection box.
2. Press the "v" button repeatedly until "ADD-ON-MODULE" is displayed in the selection box.
3. Press the ">" button to access the Add-On Module settings.
4. The selection box will have "STATUS" selected. Press the ">" button to access the "STATUS" screen. The current information will be shown.
5. When done viewing the status, press the Menu button to exit the menu and return to the main info screen.

4b. Network Settings

The Network Settings screen where the IP Address Mode (Static or DHCP), the IP Address, and Subnet Mask are set.

To change the IP Address Mode (Static or DHCP):

1. Press the Menu button. The display will show "AUDIO SETTINGS" in the selection box.
2. Press the "v" button repeatedly until "ADD-ON-MODULE" is displayed in the selection box.
3. Press the ">" button to access the Add-On Module settings.
4. Press the "v" button repeatedly until "NETWORK SETTINGS" is displayed in the selection box.
5. Press the ">" button to access the Network Settings.
6. The selection box will have "IP ADDRESS MODE" selected. Press the ">" button to highlight the "IP ADDRESS MODE" screen. The current mode (static or dynamic) will be highlighted in the selection box.
7. Press the "v" or "^" button to change the IP Address Mode.
8. Press the "<" button to exit without saving, or push the ">" button to save. The T45 will reboot if changes were saved.

To change the IP Address:

1. Press the Menu button. The display will show "AUDIO SETTINGS" in the selection box.
2. Press the "v" button repeatedly until "ADD-ON-MODULE" is displayed in the selection box.
3. Press the ">" button to access the Add-On Module settings.
4. Press the "v" button repeatedly until "NETWORK SETTINGS" is displayed in the selection box.
5. Press the ">" button to access the Network Settings.
6. The selection box will have "IP ADDRESS MODE" selected. Press the "v" button to highlight "IP ADDRESS".
7. Press ">" to access the IP address setting. The current IP Address will be shown.
8. Using the "v" or "^" buttons, change the first octet (3 digits) of the IP Address.
9. Press the ">" button to access the next octet.
10. Repeat steps 8 and 9 until the last octet has been changed. Use the "<" button to go back and edit previous octets, if needed.
11. When finished editing the IP Address, press the ">" button once to store the IP Address. The T45 will automatically reboot. When the T45 is finished booting it will be running on the new static IP Address (the T45 automatically changes to Static mode if the IP Address is changed and saved).

To change the Subnet Mask:

1. Press the Menu button. The display will show "AUDIO SETTINGS" in the selection box.
2. Press the "v" button repeatedly until "ADD-ON-MODULE" is displayed in the selection box.
3. Press the ">" button to access the Add-On Module settings.
4. Press the "v" button repeatedly until "NETWORK SETTINGS" is displayed in the selection box.
5. Press the ">" button to access the Network Settings.
6. The selection box will have "IP ADDRESS MODE" selected. Press the "v" button twice to highlight "SUBNET MASK" screen. The current Subnet Mask will be shown.
7. Press the ">" button to access the Subnet Mask setting.
8. Using the "v" or "^" buttons, change the first octet (3 digits) of the Subnet Mask.
9. Press the ">" button to access the next octet.
10. Repeat steps 8 and 9 until the last octet has been changed.
11. When finished setting the Subnet Mask, press the ">" button once to store the Subnet Mask. The T45 will automatically reboot. When the T45 is finished booting it will be running on the new Subnet Mask.

4c. Admin

The Admin screen is where the web page log in Password is set/reset (the User Name is fixed to "admin"), and displaying or not displaying the IP Address on the front of the T45 can be set.

To change the Network Log-In Password:

1. Press the Menu button. The display will show "AUDIO SETTINGS" in the selection box.
2. Press the "v" button repeatedly until "ADD-ON MODULE" is displayed in the selection box.
3. Press the ">" button to access the Add-On Module settings.
4. Press the "v" button repeatedly until "ADMIN" is displayed in the selection box.
5. Press the ">" button to access the Admin setting. "NETWORK LOG IN" will be shown in the selection box.
6. Press the ">" button to access the Network Log In (Reset Password) Screen.
7. Press the "^" or "v" buttons to change the setting to "NO" or "YES". If "YES", a confirmation screen comes up, warning that remotely connected users may have to log in again.
8. Press the "v" button to highlight "YES".
9. Press the ">" button. A confirmation screen comes up.
10. Press the "v" button to highlight "YES" and push the ">" button to reset the password.
11. Users on the web page interface must now log in using User Name: "admin" and Password: "admin". From the web page, the password can be changed to any desired password. Until the password is changed from the default "admin", a red warning bar will persist on the web page, reminding the user that the password needs to be changed.

To change the Front Display to show/not show the IP Address:

1. Press the Menu button. The display will show "AUDIO SETTINGS" in the selection box.
2. Press the "v" button repeatedly until "ADD-ON MODULE" is displayed in the selection box.
3. Press the ">" button to access the Add-On Module settings.
4. Press the "v" button repeatedly until "ADMIN" is displayed in the selection box.
5. Press the ">" button to access the Admin setting. "NETWORK LOG IN" will be shown in the selection box.
6. Press the "v" button once to display "IP ADDRESS DISPLAY" in the selection box.
7. Press the ">" button to access the IP Address Display Screen.
8. Press the "^" or "v" buttons to change the setting to "ON" or "OFF". If "OFF", the front display will not display the IP Address.
9. Press the Main Menu button to exit.

Network Setup for Hard-wired Ethernet Devices (Laptop or Desktop PC)

The PPA T45NET provides a web interface (set of web pages) to manage the transmitter settings. These web pages can be accessed over an Ethernet network, either hard-wired (through a laptop or desktop PC) or wireless (through an iPad, Android tablet, or smart phone). The web pages can be accessed with nearly all internet browsers, like any website. Nearly all of the settings that can be changed on the transmitter can be accessed and changed through the front panel controls - or the web pages. Note that the web pages have a different look and feel than the front panel menu tree, but nearly all of the same settings can be accessed (not on web page: Screen Time-out, Headphone Source, Headphone Volume).

1. It is assumed that the network has already been set up, and a laptop or desktop pc is connected on the network.

2. Determine an appropriate static IP address for the T45. If using dynamic IP Addressing, skip to step 4.

- a. If someone set up your network, they may be able to help you determine an appropriate IP address (i.e. network system administrator).
- b. There should be no other device having this same address on the network.
- c. This will be an address on the same subnet as the router.
- d. For example, if the router's address is 192.168.1.1, the first three sets of numbers will be the same (i.e. 192.168.1), and the last number will be the number you determine for the T45 (i.e. .100), making the IP address for the T45 "192.168.1.100". When you determine this address, remember or write it down. You will need it for a later step.

3. Set the Static IP Address for the T45 by using the controls on the front of the T45.

- a. Enter the IP Address you determined in step 2. (When entering/saving the new address, the T45 will automatically change its IP Address Mode to STATIC)
- b. All settings in the T45 take place immediately (they change when saved).

4. Plug the network cable into the T45.

5. Connect to the T45 with the Laptop or Desktop PC.

If using a Static IP Address:

- a. Open the web browser on the Laptop or Desktop PC.
- b. In the address bar of the browser, type in the address of the T45 (from step 2) and hit "Enter".
- c. You should see the Log In Page of the T45 (see Figure 18).
- d. Log In using the default user name "admin" and password "admin".

If using DHCP (Dynamic IP Addressing):

When using DHCP addressing, the IP Address can be viewed on the front panel of the T45NET. However, when doing remote installation, there is an optional discovery utility program available on our website called the "Williams Sound Device Discoverer Tool". This tool allows the discovery of T45NET devices on a local network and shows their IP Address.

- a. Once downloaded and installed, open the "Williams Sound Device Discoverer.jar" Tool on the Laptop or Desktop PC. (If the tool doesn't open you may need to update the PC to the latest version of Java). The T45(s) should show up with it's (their) IP Address (see figure 15). Write the IP Address down, you'll need it for a later step.

Figure 15: Williams Sound Device Discoverer Tool (optional)

- b. Open a web browser on the Laptop or Desktop PC.
- c. In the address bar, type in the IP address of the T45 (static from step 2 or dynamic from step 5) and hit "Enter".
- d. When you connect to the T45, you should see the Login Page (see Figure 17).

6. After logging in, verify control of the T45 by changing a setting from the web page, and watching it change on the T45 front panel display.

- a. An easy setting to verify is changing the channel (see Figure 20).

7. For easy access next time, build a "favorite" link to the T45 (just like you would for a favorite website).

- a. If you can't make a link, you can always go back to the IP address (step 5) by going into the website history or typing in the first few numbers of the address (i.e. "192.168") into the address bar and it should see the link you recently visited. This method is cumbersome, which is why a "favorite" link is suggested.

Note: The procedure outlined here is a simple example of the basic steps required to set up control of the T45 transmitter with a hard-wired computer. Existing network topology, security, type of devices and network preferences all contribute to how the network may be set up and how you may be able access the T45. Consult with a trained IT professional if you are unsure how you should set up network control.

Network Setup for Wireless Devices (iPad, Android Tablet, or Smart Phone)

The PPA T45NET provides a web interface (set of web pages) to manage the transmitter settings. These web pages can be accessed over an Ethernet network, either hard-wired (through a laptop or desktop PC) or wireless (through an iPad, Android tablet, or smart phone). The web pages can be accessed with nearly all internet browsers, like any website. Nearly all of the settings that can be changed on the transmitter can be accessed and changed through the front panel controls - or the web pages. Note that the web pages have a different look and feel than the front panel menu tree, but nearly all of the same settings can be accessed (not on web page: Screen Time-out, Headphone Source, Headphone Volume).

1. Get the Router IP address, Router SSID (Wi-Fi broadcasted name) and Router Wi-Fi Password.

- a. If someone set up your network, you will need to get this information from them (i.e. network system administrator). Remember or write them down. You will need these for later steps.

2. Determine an appropriate static IP address for the T45. If using dynamic IP Addressing (DHCP), skip to step 4.

- a. If someone set up your network, they may be able to help you determine an appropriate IP address.
- b. There should be no other device having this same address on the network.
- c. This will be an address on the same subnet as the router.
- d. For example, if the router's address is 192.168.1.1, the first three sets of numbers will be the same (i.e. 192.168.1), and the last number will be the number you determine for the T45 (i.e. .100), making your IP address for the T45 "192.168.1.100". When you determine this address, remember or write it down. You will need it for a later step.

3. Set the Static IP Address for the T45 by using the controls on the front of the T45.

- a. Enter the IP Address you determined in step 2. (When entering/saving the new address, the T45 will automatically change it's IP Address Mode to STATIC)
- b. All settings in the T45 take place immediately (they change when saved).

4. Plug the network cable into the T45. If using a Static IP Address, skip to step 6.

5. Find the Dynamic (DHCP) IP Address of the T45, either from the front panel, or remotely with a Laptop or Desktop PC.

When using DHCP addressing, the IP Address can be viewed on the front panel of the T45NET. However, when doing remote installation, there is an optional discovery utility program available on our website called the "Williams Sound Device Discoverer Tool". This tool allows the discovery of T45NET devices on a local network and shows their IP Address.

- a. Once downloaded and installed, open the "Williams Sound Device Discoverer.jar" Tool on the Laptop or Desktop PC. (If the tool doesn't open you may need to update the PC to the latest version of Java). The T45(s) should show up with its (their) IP Address (see figure 15). Write the IP Address down, you'll need it for a later step.

Figure 16: Williams Sound Device Discoverer Tool



6. Connect to the *Router* through Wi-Fi on the Wireless Device.

- a. Make sure the Wi-Fi is turned ON.
- b. In Wi-Fi settings, look for the router SSID you got from step 1.
- c. Click on the Router SSID to connect to it.
- d. Enter the Router Wi-Fi password you got from step 1.
- e. The wireless device should now indicate that you are “connected” to the router.
- f. Exit all the way out of the settings back to the home screen on the wireless device.

7. Connect to the *T45* with the Wireless Device.

- a. Open the web browser on the wireless device (i.e. on the iPad: Safari)
- b. In the address bar of the browser, type in the IP address of the T45 (static from step 2 or dynamic from step 5) and hit “Enter”.
- c. When you connect to the T45, you should see the Login Page (see Figure 17).

8. After logging in, verify control of the T45 by changing a setting using the wireless device, and watching it change on the T45 display.

- a. An easy setting to verify is changing the channel (see Figure 20).

9. For easy access next time, build a “favorite” link to the T45 (just like you would for a favorite website).

- a. If you can’t make a link, you can always go back to the IP address (step 7) by going into the website history or typing in the first few numbers of the address (i.e. “192.168”) into the address bar and it should see the link you recently visited. This method is cumbersome, which is why a “favorite” link is suggested.

Note: The procedure outlined here is a simple example of the basic steps required to set up control of the T45 transmitter with a wireless device. Existing network topology, security, type of devices and network preferences all contribute to how the network may be set up and how you may be able access the T45. Consult with a trained IT professional if you are unsure how you should set up network control.

Web Control Interface

The PPA T45NET provides a web interface (set of web pages) to manage the transmitter settings. These web pages can be accessed over an Ethernet network, either hard-wired or wireless, with most internet browsers. Transmitter settings can be accessed and changed through the front panel controls - and/or this web interface. Some changes take place live, while others take effect when “applied” or saved. Any updates made through the front panel will show up on the web interface, and vice-versa.

Figure 17: Main Login Page and Ethernet Communication Status

The Password is stored inside the T45. The User name is “admin” and the default password is “admin”. The user name is not changeable but the password can (and should) be changed (on the web “Admin” page).

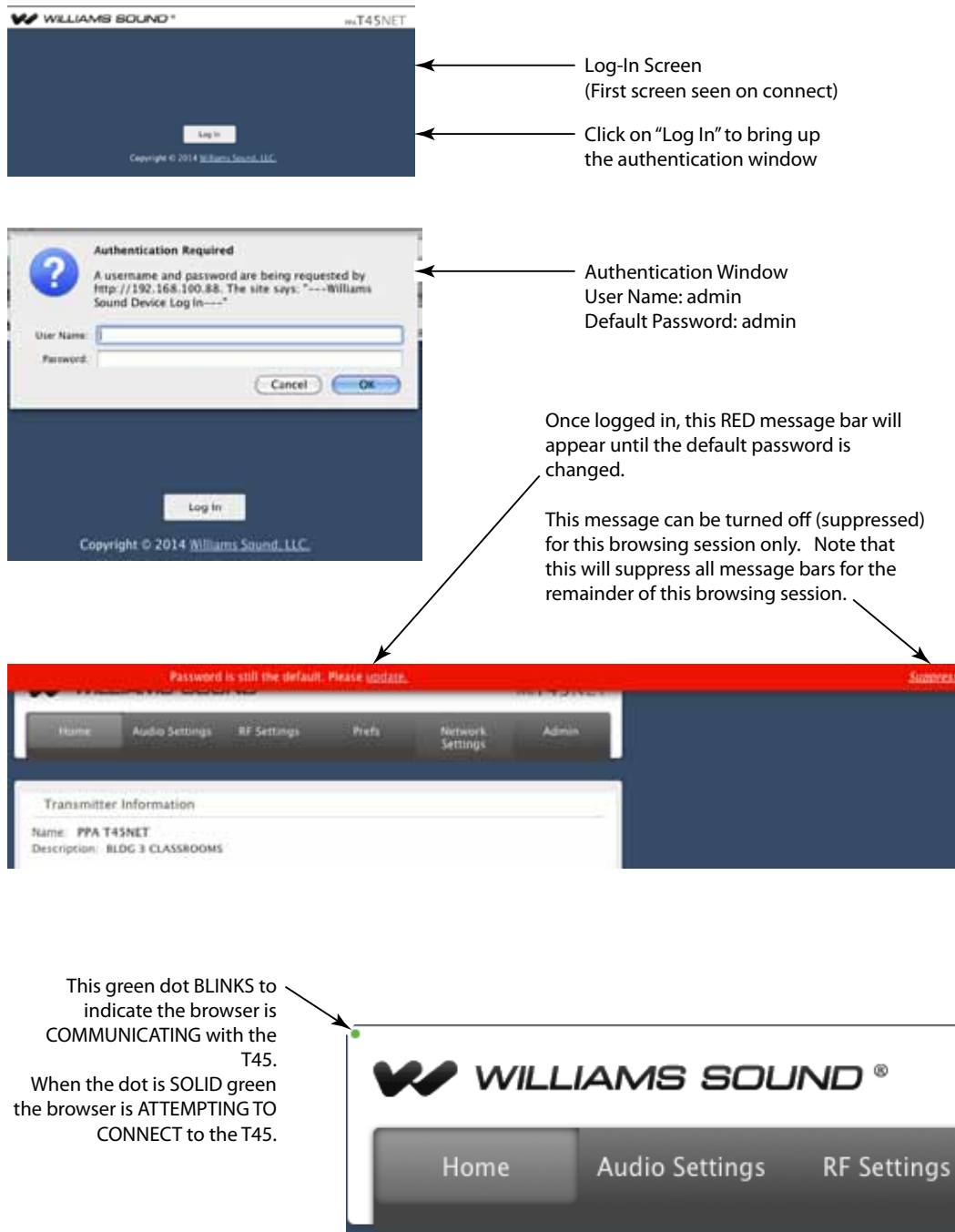

Figure 18: Home Page and Event Log

The Home Page shows a summary of the T45 status; there are no controls on this page.

The Event Log is only active during each browsing session. When the browser is closed, the log is cleared. When the browser is re-opened, a new event logging session begins.

Click here to display Event Log

Transmitter Name (not user-changeable)

Transmitter Description (changeable through web interface and front panel)

Front Panel Display (live)

Audio Level Monitor On/Off

Audio Level Monitor

Self Tests pass only if browser is communicating with the T45

RF Power Level and Status

Log Out Button appears on all pages

Link to online User Manual

Event Log

(Click on "PPA T45NET" on the top right to display -or- also available on the "Admin" page)

Date / Time	Setting	Old Value	New Value	Change Source
1/29 10:06:58	Channel	2	5	LOCAL
1/29 10:07:00	RF Level	1	2	LOCAL
1/29 10:07:04	RF Timeout	2	1	LOCAL
1/29 10:07:20	Description	YOUR T45 NAME HERE	NORTH HALL 2	LOCAL
1/29 10:07:22	Description	NORTH HALL 2	NORTH HALL 2	LOCAL
1/29 10:07:45	Audio Source	AES/EBU	S/PDIF	LOCAL
1/29 10:07:59	Panel Lock	0	1	LOCAL

Figure 19: Audio Settings Page

The Audio Settings page displays all current audio settings, as well as corresponding T45 web-based controls.

Note: Turning off the Audio Level Monitor may improve performance of the webpage, particularly on mobile devices that have less processing power. Network speed can also affect the audio monitor updating and web page performance.

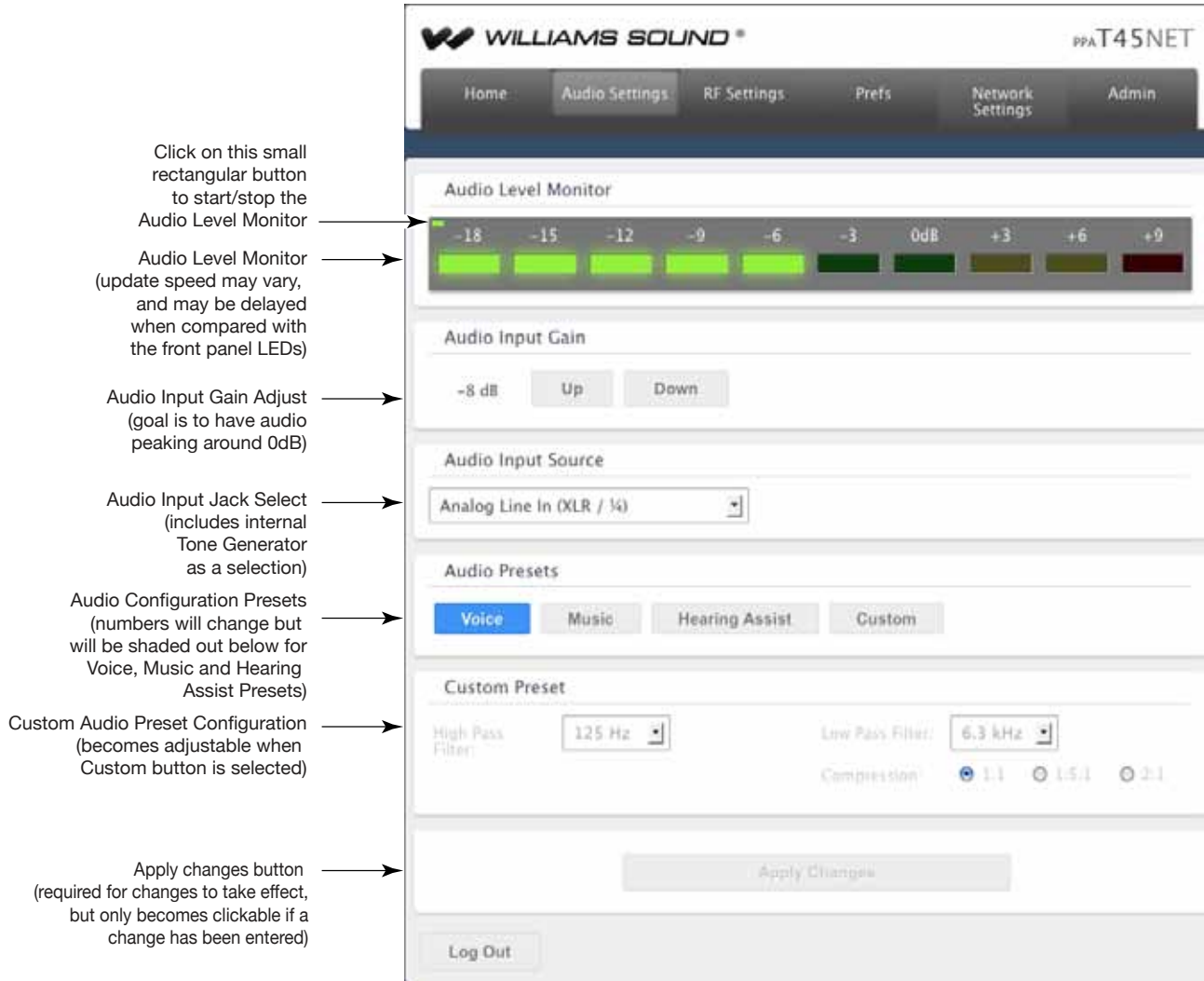

Figure 20: RF Settings Page

The RF Settings page displays all current RF-related settings as well as corresponding T45 web-based controls.

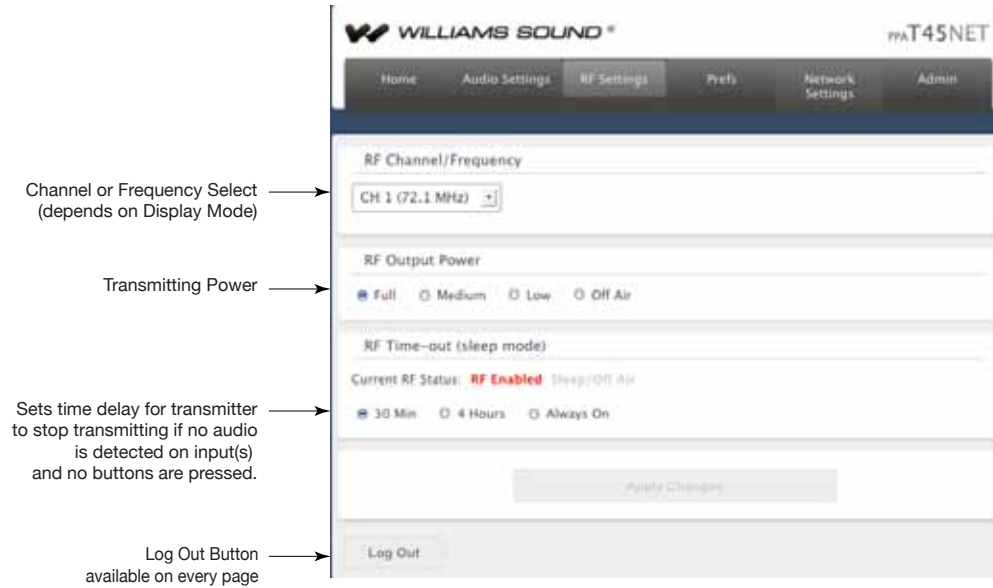

Figure 21: Preferences Page

The “Prefs” page displays user preferences that can be tailored to each T45 application.

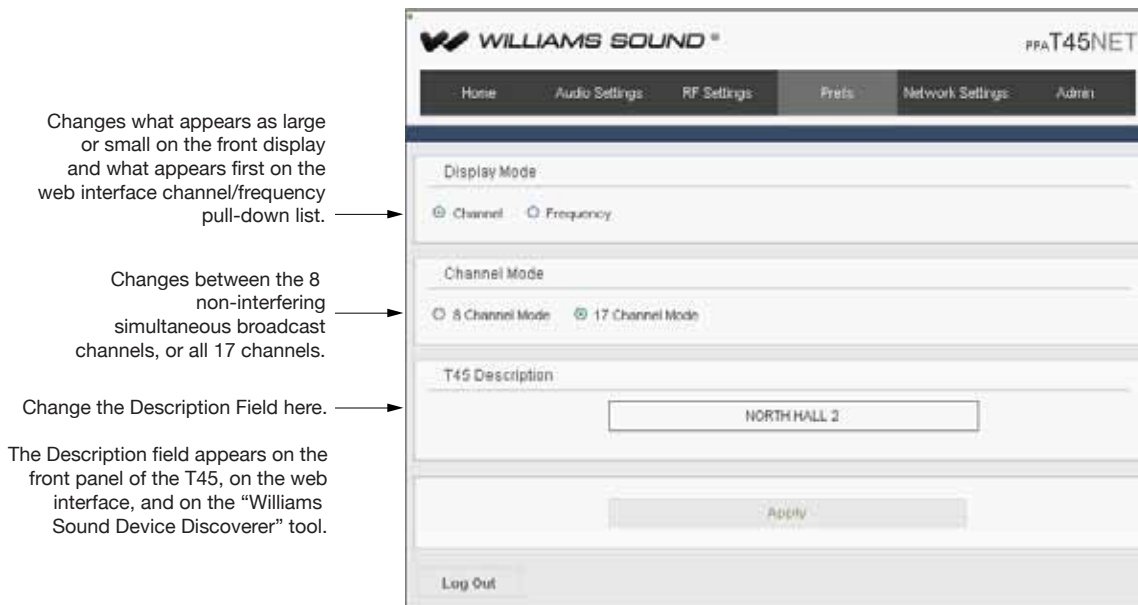

Figure 21: Network Settings Page

The Network Settings page displays NET connectivity settings. Typically these are not needed after initial installation.



Figure 22: Administration Page

The “Admin” page displays administrative controls that can be used to help with non-technical T45 users, or for remote site troubleshooting purposes.

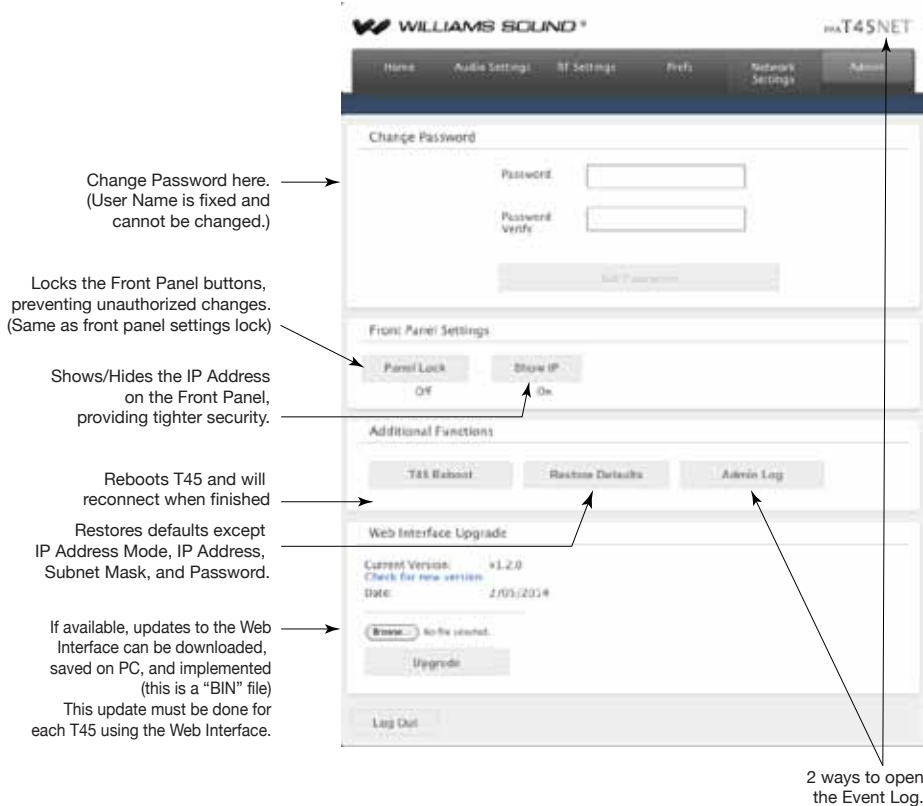

Receiver Safety Information

HEARING SAFETY

CAUTION!

This product is designed to amplify sounds to a high volume level which could potentially cause hearing damage if used improperly. To protect your hearing and the hearing of others:

1. Make sure the volume is turned down before putting on the earphone or headphone before adjusting the volume to a comfortable level.
2. Set the volume level at the minimum setting that you need to hear.
3. If you experience feedback (a squealing or howling sound), reduce the volume setting on the receiver, and (if this applies) move the microphone away from the receiver's earphone or headphone.
4. Do not allow children or other unauthorized persons to have access to this product.

BATTERY SAFETY AND DISPOSAL

CAUTION!

This product may be supplied with alkaline batteries. Do not attempt to recharge alkaline batteries, which may explode, release dangerous chemicals, cause burns, or other serious harm to the user or product.

PACEMAKER SAFETY

CAUTION!

1. **Before** using this product with a pacemaker or other medical device, consult your physician or the manufacturer of your pacemaker or other medical device.
2. If you have a pacemaker or other medical device, make sure that you are using this product in accordance with safety guidelines established by your physician or the pacemaker manufacturer.

Recycling Instructions

Help Williams Sound protect the environment! Please take the time to dispose of your equipment properly.



Product Recycling:

Please do NOT dispose of your Williams Sound equipment in the household trash. Please take the equipment to a electronics recycling center; OR return the product to the factory for proper disposal.



Battery Recycling:

Please do NOT dispose of used batteries in the household trash. Please take the batteries to a retail or community collection point for recycling.

Wideband FM Receivers (Model Selection is Optional)

Receiver Model PPA R38

PPA R38 is a 17-channel receiver operating on the 72-76 MHz bandwidth. Features include an easy to read graphic display, front buttons with easy access to menu functions, battery-saving Sleep/Auto-Off Mode, digital volume control, power/low battery indicator, and stereo/mono earphone/headphone jack.

Figure 23: PPA R38 Controls and Display

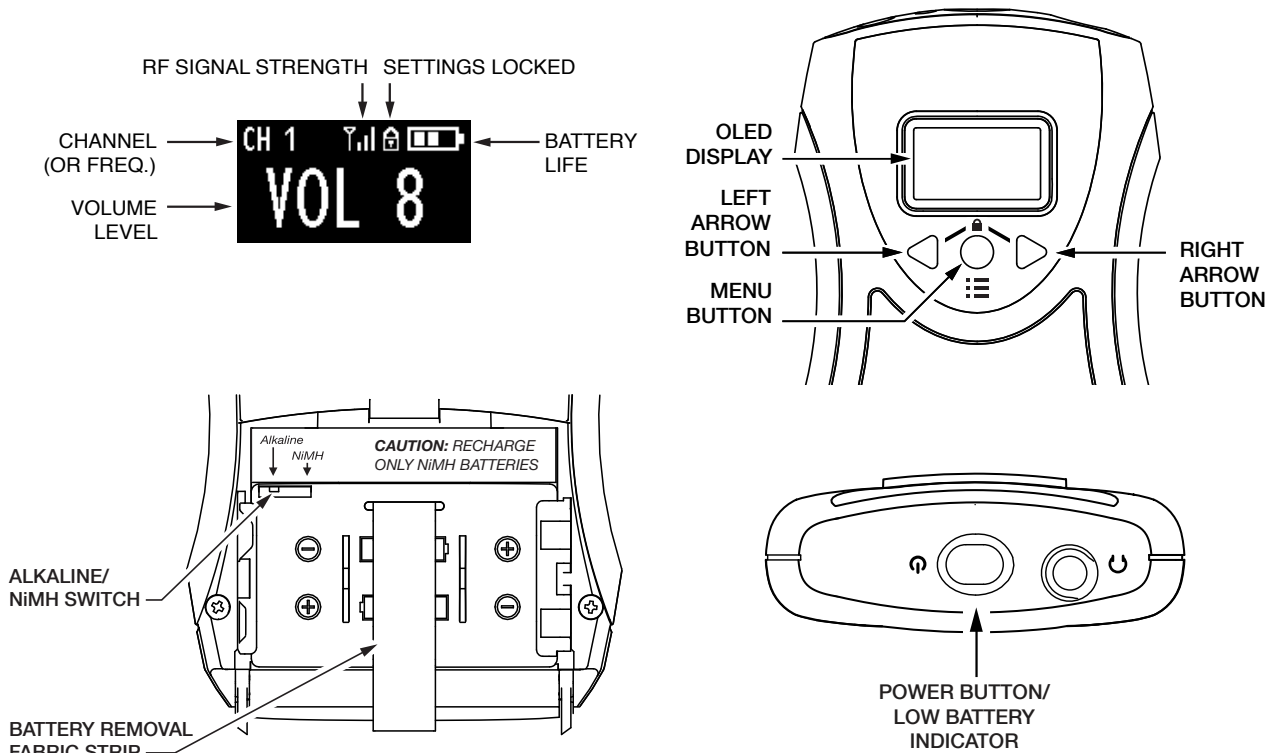

Operating the receiver

1. Insert two (2) AA batteries ensuring correct polarity. If rechargeable NiMH batteries are to be used with the receiver and a Williams Sound charger, make sure the Alkaline/NiMH switch inside the battery compartment is set to NiMH before charging. (Figure 23).
2. Insert the headphone, earphone or neckloop into the headphone jack.
3. Turn receiver on with a push-and-hold of the power button. The power button will illuminate and the display will turn on.
4. Press the Menu button once to see the Channel set screen. To seek an active transmitter, push-and-hold one of the left or right arrow buttons and the receiver will seek to find an active transmitter channel. If more than one transmitter is being used, push-and-hold the arrow button additional times until you locate the transmitter/channel you want to hear. The receiver will retain the channel setting when the unit is turned off.
5. For more information about the R38 receiver, refer to the PPA R38 User Manual. You can download any of the receiver manuals from our website at www.williamssound.com.

Wideband FM Receivers (continued)

Receiver Model PPA R37

PPA R37 is a 17-channel receiver operating on the 72-76 MHz bandwidth. Features include, seek-button channel selection, channel-lock capability, battery-saving Sleep Mode, on/off volume control, power/low battery indicator, and stereo/mono earphone jack.

Figure 24: PPA R37 controls

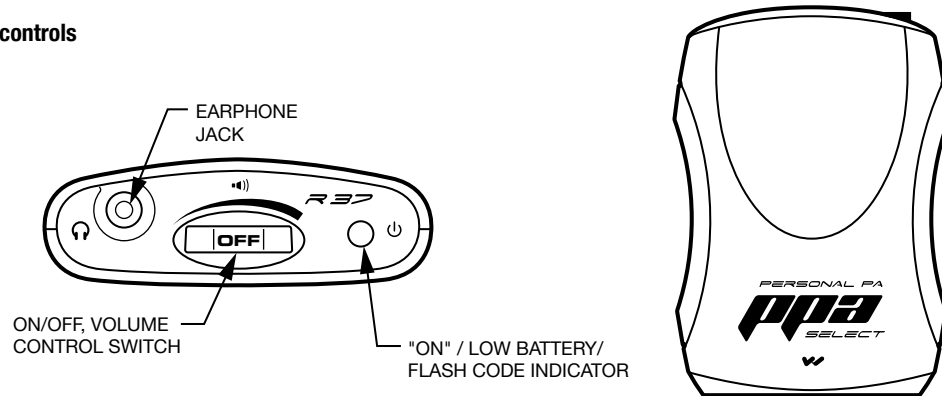

Operating the PPA R37 Receiver

1. Insert two (2) AA batteries ensuring correct polarity. If rechargeable NiMH batteries are to be used with the receiver and a Williams Sound charger, make sure the Alkaline/NiMH switch inside the battery compartment is set to NiMH before charging. See Figure 25.
2. Insert the headphone, earphone or neckloop into the headphone jack.
3. Turn receiver on by turning up the volume control. The green power LED will turn on.
4. Press the Channel Seek button inside the battery compartment once to seek an active transmitter. See Figure 25. If more than one transmitter is being used, push the seek button additional times until you locate the signal you want to hear. The receiver will retain the channel setting when the unit is turned off.
5. To lock or unlock a selected channel, turn the power off. While holding the seek button, turn the power back on. When locked, the receiver will remain on the current channel regardless of channel seek button presses.
6. For more information about the R37 receiver, refer to the PPA R37 User Manual. You can download any of the receiver manuals from our website at www.williamssound.com.

Figure 25: Battery and channel selections

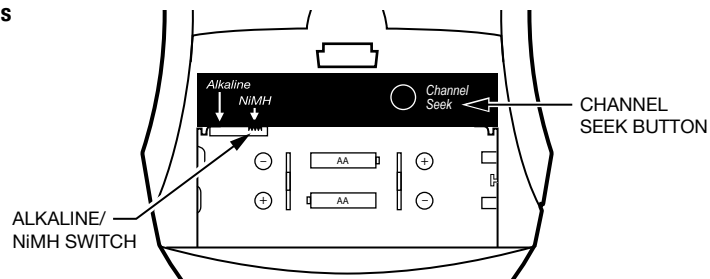

LED Flash Codes

Light Code	Indicates	Description
1 blink	Channel locked	Seek press remains on current channel
2 blinks	Channel unlocked	See press tunes to next channel present
3 blinks	Channel unlocked; no other channels present	Seek press attempts to find another channel
On-Off-On-Off...(continuous)	Batteries are low	Batteries need to be replaced or recharged
Fade-on, Fade-off... (continuous)	No transmitter present on current channel	Sleep/Power Save mode (extends battery life)

Receiver Model PPA R35-8

The PPA R35-8 is an eight channel receiver, operating on 72-76 MHz bandwidth. It features a channel selection knob, on/off volume control, LED power and low battery indicator, and an earphone jack (See Figure 26).

Figure 26: PPA R35-8 controls

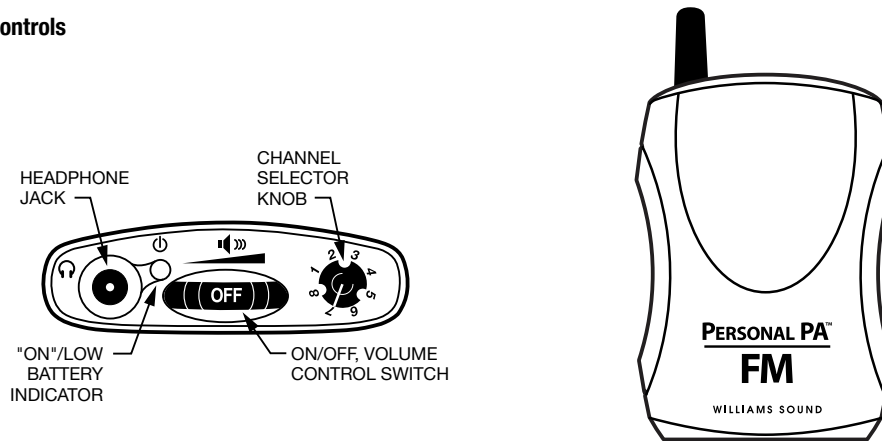

Operating the PPA R35-8 Receiver

Turn the receiver on by rotating the Volume control knob. The ON indicator should illuminate RED. Refer to the channel selection chart in Figure 14 to choose from 8 standard frequencies. Turn the channel selector knob to the desired channel.

IMPORTANT: Make sure the receiver frequency matches the transmitter frequency!

Adjust the volume to a comfortable listening level. To turn the receiver off, rotate the Volume control knob to the left until it clicks off. The ON indicator should not be lit. To prolong the battery life of the unit, turn the receiver off when it is not in use. For more information about the R35-8 receiver, refer to the PPA R35-8 User Manual. You can download any of the receiver manuals from our website at www.williamssound.com.

Connecting Earphones/Headphones

Plug the earphone/headphone into the headphone jack on the top of the unit. The PPA R35-8 only works with monophonic earphones. If stereo headphones are used, sound will be heard only in one side. The PPA R38 and PPA R37 will work properly with stereo or mono headphones. Williams Sound evaluates each earphone and headphone used with the PPA R38, PPA R37 and PPA R35-8 receivers; we can only assure optimum performance when Williams Sound earphones and headphones are used.

Battery Installation (All Receiver Models)

Install two (2) AA alkaline or NiMH rechargeable batteries. Open the battery compartment by lifting the tab on the back of the receiver with a finger. To remove depleted batteries, pull up on the fabric strip. **IMPORTANT:** If Alkaline (non-rechargeable) batteries are being installed, slide the battery selection switch above the battery compartment to the "Alkaline" position. If installing NiMH (or rechargeable) batteries, slide the battery selection switch to the "NiMH" position (see Figure 25). Press the batteries into place over the fabric strip. Be sure to observe proper polarity (+/-). Damage due to improper battery installation may void the warranty on the product. Close the battery door. When the sound becomes weak or distorted, replace or recharge the batteries. **NOTE:** The "ON" indicator on top of the unit will flash to indicate low battery.

Belt Clip Installation (All Receiver Models)

To Install:

Position the belt clip on the rear of the PPA R37, PPA R35-8, or PPA R38 receivers as shown in Figure 27. Turn the belt clip 180° left or right as shown in Figure 27. The belt clip is now installed and ready for use.

To Remove:

Turn the belt clip 180° so the edge points toward the top of the unit as shown in Figure 27. Gently pull the belt clip away from the unit to remove.

Figure 27: Belt Clip Installation and Removal

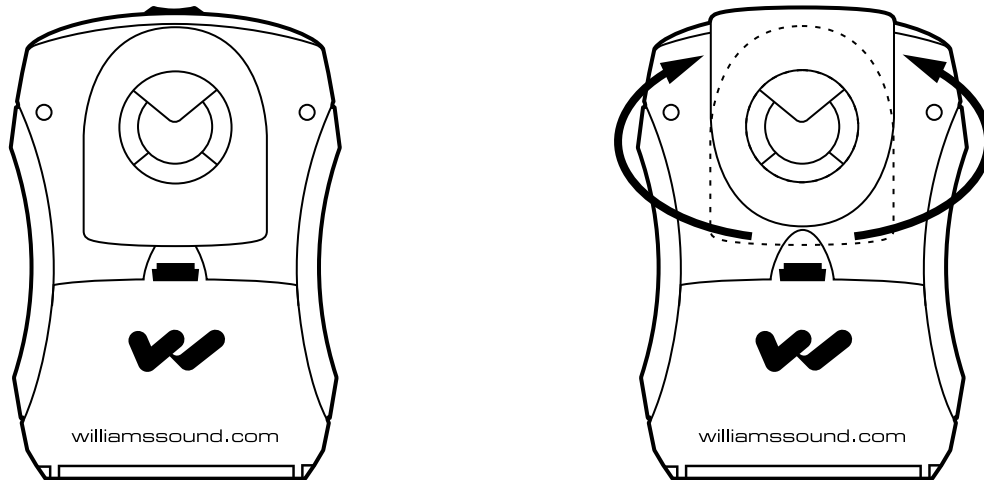

Earpad Cleaning for Earphones and Headphones

Do not immerse the earphone in water or other cleaning agent. Foam pads may be removed and washed with a mild laundry soap solution, rinsed thoroughly, and air dried. You may also opt to purchase new foam pads.

Call Customer Service for ordering information: **1-800-843-3544**

Suggestions For Receiver Management

Different types of facilities use varying approaches to receiver management and earphone sanitation. Following are some options that customers have used successfully:

1. Regular users purchase or are given their own receiver and also take care of their own batteries and earphones.
2. The facility labels a receiver and earphone for each regular user. The facility maintains the units.
3. Ushers issue receivers to people who request them.
4. Earphones are sanitized after use. Foam ear cushions can be replaced or washed with a mild detergent, rinsed thoroughly and air-dried. The EAR 022 Surround Earphone can be sanitized with an alcohol pad.
5. The receivers can be stored in a multiple compartment storage case with a credit card or driver's license left as collateral for the receiver.
6. Regular users purchase their own earphone or headphone and bring them to use with receivers at the facility.

Receiver Battery Information (All Receiver Models)

If the receiver sound becomes weak or distorted, replace the batteries. The indicator light may remain on, even with batteries that are weak. Do not leave dead batteries in the receivers. The chart below shows typical battery life with Williams Sound's 72-76 MHz receivers:

Model	Battery Type	Battery Life
PPA R38,	Alkaline AA Batteries (BAT 001-2)	50 hours
PPA R35-8, PPA R37	Rechargeable AA NiMH (BAT 026-2)	32 hours

Battery Charger Information

IMPORTANT: Batteries installed in the receiver may only be charged if they are NiMH batteries, and only if a Williams Sound charger is used. Make sure the receiver is turned off during charging! Use the chart below to select a charger for your Williams Sound 72-76 MHz receiver.

Model	Charger
PPA R38, PPA R35-8, PPA R37	Recharge batteries only with the CHG 3512 Multi-Charger or CHG 3502 Dual-Bay units. For additional charging instructions, refer to the manual included with the charger unit.

!! IMPORTANT WARNINGS !!

**DO NOT ATTEMPT TO RECHARGE ZINC CARBON ("HEAVY DUTY"), ALKALINE, OR LITHIUM BATTERIES!
DO NOT ATTEMPT TO RECHARGE DISPOSAB BATTERIES!**

These batteries may heat up and explode, causing possible injury and damage to the equipment. Avoid shorting the plus and minus battery terminals together with metal objects. Battery damage and burns can result! Use only Williams Sound supplied chargers and rechargeable batteries!

Troubleshooting

The T45 “RF” (On Air) Indicator is not on

- Ensure the transformer (TFP 048) is plugged into the transmitter and any remote power switch is on.
- Ensure the electrical outlet is on.
- Ensure the power button on the front of the T45 is pressed to the “on” position.
- Ensure the 24 VDC power supply is working.
- Ensure the RF output is not set to “OFF.”
- Ensure there is audio present. The RF will time-out and shut off if audio is not present for a period of time (if the RF Time-out was set to 30 min or 4 hr in the menu).

No Audio heard in Phones jack

- Check to see if there is a signal coming from your audio source. Check and correct your audio source if necessary.
- Check to see if the Headphone Volume Level has been turned all the way down. If so, increase it.
- Check to see if there is an incorrect or defective connection from your audio source. See Figure 6 for detailed connection instructions.

Noise or Distortion in the Audio

- Check to see if there is noise in the audio source. To find out, disconnect the audio cable. If the noise disappears your noise problem is in the source. Correct or repair your audio source.
- Ensure the Audio Source configuration is set to match the audio source input device. See “Audio Input Settings” to properly configure the Audio Source.
- Check to see if the Audio Input level is set too high. If the “input overload” message is shown on the display, then the audio level needs to be adjusted. See Figure 7 - Audio Input Level hot buttons.
- Check for ground loops or noise on the input signal. See Figure 4 for more information. If you are still having trouble, call your Authorized Williams Sound dealer or representative.

Noise in audio “grows” when program is silent

- The Audio Level Control may be set too high. You’re probably also seeing the +6 level indicator lighting all the time. To correct, adjust the Audio Level control on the front of the T45. See Figure 7 - Audio Input Level hot buttons.
- Check the T45 Compression Ratio, which may be inappropriate for the type of program being transmitted. Try setting the Compression Ratio to 1:1 (compression off). See “Audio Settings - Audio Presets - To set up a custom audio preset”.

Reception difficulties

NOTE: Be sure to listen to the audio transmission on the T45 phone jack prior to checking the receiver reception.

No Reception

- Ensure the antenna on the T45 has been connected correctly.
- Check the RF Output Power setting. It should be “FULL”, “MEDIUM” or “LOW” power. See “RF Settings - RF Output Power”.
- Ensure the FM receiver is ON. Ensure the batteries are properly installed (observing proper polarity). If the batteries are rechargeable, it may be necessary to charge the batteries overnight.
- Ensure the FM receivers are operating on the same frequency as the T45.

Insufficient range, good reception near transmitter, poor at a distance

- Ensure the transmitting antenna was installed as specified in this manual. If not, correct or replace the antenna. If a remote antenna was installed, check the cables and connections. The signal should be clearly audible up to at least a 100-foot distance with the ANT 005 or ANT 025.

- Ensure the transmitting antenna is not in an unsuitable location. Perhaps the transmitting antenna was installed inside a metal enclosure or is separated from the reception area by electrically conducting objects. (i.e., steel stud walls, heating ducts, substantial structural steel, or 2x2 or 2x4 ceiling grid.) In either case, reinstall the antenna according to installation instructions, locating it outside metal enclosures and away from electrically conducting objects.
- A strong interfering signal may exist. Ensure the transmitter and antenna are correctly installed. Set the transmitter to FULL power output. If this does not solve the problem, try operating the transmitter on a different channel/frequency.

Users must turn receiver volume controls way up (near maximum) to get enough volume

- Insufficient audio level may be the problem. If so, the audio level indicator will read too low because the audio gain control is set incorrectly on the transmitter. Correct the Audio Gain control setting by adjusting it until the sound level peaks between 0 and 6 dB. See Figure 7 - Audio Input Level hot buttons.
- It could be that the audio input is not configured for the audio source being used. If not, correct the setting of the Audio Source control menu. See "Audio Input Settings".
- Some users may not be helped by this system. Severe hearing loss may require using the system with a telecoil coupler (i.e., Neckloop) and personal hearing aid.
- Check your batteries. For non-rechargeable (alkaline) batteries, they may need replaced. If you are using rechargeable batteries, ensure the batteries are fully charged prior to use.

Users complain of too much noise during soft audio. Dynamic range of music reduced too greatly.

- The Audio Level control may be set too high. This problem is more likely to occur in 2:1 or 1.5:1 Compression modes, but can also occur in 1:1 Compression mode. To reduce the noise, adjust the Audio Level, carefully noting the Level Indicator. The +6 LED should light occasionally.
- The transmitter could be set for High Compression (2:1) when Reduced Compression (1.5:1) or No Compression (1:1) would be more suitable, given the program material. If so, set the Compression Ratio to 1.5:1 or 1:1 and see if this reduces the noise. See "Audio Settings - Audio Presets - To set up a custom audio preset".

Buzz in other equipment when transmitter is on or off

- This is not an RF problem. Instead, it is likely caused by incorrect audio connections, a ground loop, or defective equipment. To remedy, use proper audio wiring practice to make connections shown in Figure 6 (and Figure 4 if needed).

Buzz or other noise in equipment only when transmitter is on

- This is likely an RF-induced disturbance in the other equipment. To remedy, try these steps in order until the buzz is eliminated:
 1. Make certain the transmitter chassis is connected to the equipment cabinet rails. Buzz/hum in system may be experienced when the T45 chassis is insufficiently grounded. In this case, install a ground wire to the T45 chassis and terminate to a verified ground source.
 2. Ensure antenna connections are secure.
 3. Set the T45 Transmitter to MEDIUM power output on the RF Power menu choice.
 4. Install transmitter at a distance from sensitive equipment.
 5. Use a remote antenna (ANT 005 or ANT 024).
 6. Make sensitive equipment more immune to RFI/EMI. The manufacturers of your audio equipment may offer application notes for this purpose. Williams Sound offers a document giving suggestions for improving RF immunity in existing audio equipment (Technical Bulletin: Buzz Or Hum In The Sound System, FRM 531).

Remote Control is not working over the hardwired Ethernet network

- **Please note:** If you have a network system administrator, please contact them first before attempting to troubleshoot the network yourself. The following steps are things you can try on a small, non-managed network.
- In this situation you have to check the entire signal path between the control device (laptop or desktop computer) and the T45. You can save some time by “pinging” the router and T45. Pinging allows you to verify the wiring path without physically having to trace the wires themselves.
 1. In order to perform these steps you will need the IP address of the T45 and the router. You can find the IP address of the T45 by using the Williams Sound Device Discoverer Tool on a PC that is on the network.
 2. Make sure the T45, Router, and any other devices in the signal path (i.e. an Ethernet switch) are all connected and powered ON.
You can save time tracing wiring/hardware paths with these next three steps:
 3. Open a CMD window on the computer. (For example, to do this on a Windows XP/Vista/7 PC, click on the Windows symbol on the lower left corner of the screen. In the search box, type “CMD”. A black box should come up and the cursor will be blinking.)
 4. Type “ping” followed by a space, followed by the IP address of the T45, and hit Enter. If you see a “reply from...[ip address]” this means the hard-wired Ethernet path is ok. If this is ok, skip to step 8. If you see “request timed-out”, there is most-likely a break in the wiring path between the computer and the T45.
 5. Try “pinging” the IP address of the router. If you can get a “reply from...” the router, but not the T45, the problem is either in the wiring between the router and T45, or the T45 itself could be malfunctioning. If the router doesn’t reply, go to step 6. If the router does reply, skip to step 8.
 6. Now you’ll have to check all of the wiring between the computer and the T45. Make sure every device in the signal path is plugged in, connected, and powered ON. *Note: when checking connections make sure the T45 Ethernet cable is plugged into one of the LAN ports on the router, not the WAN port.* Re-seat (unplug and plug back in firmly) all Ethernet cables in the path between the computer and the T45. If you find one that was loose, plug it in (if none are loose, you could also replace Ethernet cables) and go back to step 4. Keep repeating this process until the T45 pings successfully. If it does, skip to step 8.
 7. If no loose cables were found in step 6, try re-booting **in this order** (1) the router (2) the computer and (3) the T45 (turn it off for 10 sec then turn it back on). Wait at least **two full minutes** for the T45 to re-establish itself on the network. Then try pinging it again (go back to step 4).
 8. At this step you have verified that you can ping the T45 from the computer. Open an internet browser on the computer. Type the IP address of the T45 into the address bar of the Internet browser. (i.e. it will be something like 192.168.1.100) Or, if the address is already there from a previous connection, just refresh the browser.
 9. Verify the connection by changing a setting on the T45 through the internet browser. If you can change settings and get feedback on the web page (or verify the change on the front display of the T45) you are now connected to the T45.
 10. If you can make changes to the T45 initially but then lose that ability (get disconnected), you may have to look at deeper network issues such as IP address conflicts, power issues, or even settings in the router.
 11. You can try restoring the T45 to factory settings. This will clear out any changes and allow you to start clean with either a DHCP IP Address, or a Static IP address (you will need to choose Static Address Mode and enter the IP Address). Make sure when entering a static IP address that it is compatible with the network IP structure, and also does not conflict with any other device IP addresses on the network.
 12. Try directly connecting the T45’s Ethernet cable to a PC to verify that the T45 and Ethernet cable are operational.
 13. If you have tried all of these steps and still can’t connect, call Williams Sound for additional troubleshooting help. Note that Williams Sound cannot help in all cases, as there are many variables within networks.

Remote Control is not working over Wi-Fi

- **Please note:** If you have a network system administrator, please contact them first before attempting to troubleshoot the network yourself. If you don't have a system administrator, the following steps are things you can try on a small, non-managed network.

- This situation is **most often** caused by the mobile device losing connection to the router when the Wi-Fi on the mobile device has been turned off (or the wi-fi reception is unstable).

1. In order to perform these steps you will need the SSID of the router, the router wi-fi connection password/passkey (not the administrative password-these are two different passwords), and the IP address of the T45. You can find the IP address of the T45 by going into the Menu on the T45 itself (using the front buttons and display).
2. Make sure the T45 and Router are both ON.
3. Make sure the Ethernet cable going to the T45 is plugged into one of the LAN ports on the router (not the WAN port).
4. Is the mobile device connected to the router? On the mobile device, go into the Wi-Fi Settings, and make sure Wi-Fi is turned on or enabled. More than one router may show up in the list of possible connections, depending upon how many routers are nearby. If you don't see the router that is connected to the T45 in the list, make sure the router is ON and broadcasting its SSID.
5. If you see the desired router SSID in the list, connect to it by clicking on it. Usually there is a check mark or some other indication of which router/SSID you are connected to. You may need to enter the wi-fi password/passkey to the router to connect to it.
6. Once you have verified that you have connected the mobile device to the router, exit the Wi-Fi settings on the mobile device (without shutting off the Wi-Fi) and open an internet browser. Type the IP address of the T45 into the address bar of the Internet browser and hit the Enter key. You should see the T45 login web page come up.
7. Verify the connection by changing a setting on the T45 through the internet browser. If you can change settings and get feedback on the web page (or verify the change on the front display of the T45), you are now connected to and controlling the T45.
8. If step 7 didn't work, try re-booting **in this order** (1) the router (2) the computer and (3) the T45 (turn it off for 10 sec then turn it back on). Wait at least **two full minutes** for the T45 to re-establish itself on the network. Then try pinging it again (go back to step 5).
9. If you can make changes to the T45 initially but then lose that ability (get disconnected), you may have to look at deeper network issues such as IP address conflicts, power issues, or even settings in the router. Fixing the router to one Channel as opposed to letting the router hunt between channels (as in "Auto Mode") is one thing to try, and can improve connection stability.
10. If there is interference, or low Wi-Fi signal on the mobile device, try moving the router to a better location.
11. Some mobile devices have known issues with certain routers. To fix this, you can investigate updating the operating system on the mobile device. Or, try a different mobile device just to verify that ANY wireless device can connect. If you can get one device connected, but not another, chances are the device that cannot connect has issues. A different brand/model of router may also fix the problem with certain devices not connecting.
12. You can try connecting a computer directly to the T45 with a standard Ethernet cable to verify that the Ethernet connection on the T45 is working. Once this has been verified you can place the T45 back on the network and begin troubleshooting back to the mobile wi-fi device.
13. Try connecting to the T45 using Wi-Fi on a laptop, rather than a mobile device, to verify that the mobile device is/is not the problem. If you can connect with a laptop, check the Wi-Fi settings on the mobile device and make sure Wi-Fi is turned On.
14. You can try restoring the T45 to factory settings. This will clear out any changes and allow you to start clean with either a DHCP IP Address, or a Static IP address (you will need to choose Static Address Mode and enter the IP Address). Make sure when entering a static IP address that it is compatible with the network IP structure, and also does not conflict with any other device IP addresses on the network.
15. If you have tried all of these steps and still can't connect, call Williams Sound for additional troubleshooting help. Note that Williams Sound cannot help in all cases, as there are many variables within networks.

System Specifications PPA T45, PPA T45NET Transmitters

Dimensions	8.45" W x 8.25" D x 1.72"H (21.5 cm x 21 cm x 4.4 cm)
Weight	Transmitter: 3.0 lbs (1.36 kg)
	Shipping Weight: 4.50 lbs (2.04 kg) (Transmitter, Power Supply, Antenna and packaging)
Color	Black/Silver with black legends on the front, white legends on the back
Rack Mount	Standard 19" Rack, one EIA rack space high, 1/2 space wide 1-2 units can be mounted in a single rack space with optional RPK 005 (single) or RPK 006 (double) Rack Mount Kits
Power Supply	Desktop Style Transformer (TFP 048)
	Input: 100-240 VAC, 50/60 Hz. IEC Line Cord
	Output: 24 VDC, 750 mA, 18W. 2.5mm ID center positive barrel connector
	Approvals: UL, CUL, Energy Star V, CSA listed
Power ON Indicator	Push On/Push Off latching power button, backlit green indicates power ON, backlight off indicates power OFF, fading from bright to dark indicates Sleep Mode*
Temperature Range	Operating: +32° F to +104° F (0° C to 40° C)
	Storage: -4° F to +158° F (-20° C to 70° C)
Menu Settings	Audio Presets (Music, Voice, Hearing Assist, Custom), Frequency/Channel selection, Frequency/Channel mode, Audio Input Source (Microphone, Line, Phantom, Digital AES/EB, Digital S/PDIF), High Pass Filter, Low Pass Filter, Compression, RF Output Power, Screen Saver Delay, Test Tone (400 Hz), Headphone Volume, Headphone Source

RF Section

Operating Frequencies	72.1-75.9 MHz , 17 wideband channels (selectable)
Frequency Accuracy	± 2 ppm stability, 0-50° C
Deviation	± 75 kHz maximum
Pre-Emphasis	75 µsec
RF Field Strength	Does not exceed 80 mV/m at 3 m
Compatible Antennas	ANT 005, ANT 021, ANT 024, or ANT 025
Transmission Range	Up to 1000 ft (304 m) with ANT 005 coaxial antenna mounted on rear chassis connector
*RF Time-out (Sleep Mode)	Menu selectable - 30 Min, 4 Hours, or Always On; timer starts when audio is below the -21dB VU level and no buttons are pressed
RF Power	Menu selectable - Full, Medium, Low, Off
RF Outputs	(1x) #10-32 stud connector in center of unit (pcb mounted)
	(1x) F-connector on rear chassis
RF Transmit Indicator	1 Green LED, indicates RF "On Air"

Audio Section

Audio Processor Functions	DSP based; Compression: 1:1, 1.5:1 or 2:1; High Pass and Low Pass Filter Frequency control
Frequency Response	31 – 16000 Hz, ±3 dB ("Music" Audio Preset)
Signal-to-Noise Ratio	≥74 dB Transmitted RF
Total Harmonic Distortion	Less than 0.25% @ 1 kHz (RF output)
Common Mode Rejection	>57 dB @ 1 kHz, Mic or Line

System Specifications PPA T45, PPA T45NET Transmitters (continued)

Audio Inputs	(1x) Combination 3-pin XLR, 1/4" (TRS) jack for Mic or Line Level Analog Audio, Balanced or Unbalanced Line Level, or Microphone with Selectable Phantom Power (1x) XLR for Digital Audio, AES3/EBU, supported sample rates 44.1 kHz and 48 kHz (1x) RCA for Digital Audio, S/PDIF, supported sample rates 44.1 kHz and 48 kHz		
Audio Input Gain Adjust	In menu, adjustable to 0 to -50 dB, in 1dB steps		
Phantom Power	14.4 VDC applied through 2.2 kΩ resistors to analog combo jack: Pin 2 and Pin 3 on XLR jack, or tip and ring on 1/4" TRS jack		
Audio Level Indicators	10-LED array that reads -18 to +9 dB at 3 dB intervals. 7 Green, 2 Amber, and 1 red LED. Green LEDs indicate normal operating audio level peaks, Amber LEDs indicate close to overload peaks, Red LED indicates overload peaks		
Input Levels (Bal or Unbal) (at Audio Input Gain = 0dB)	Nominal (1st Amber LED)	Overload Warning (Displayed on Screen)	Absolute Maximum Ratings**
Microphone	-55 dBV (1.7 mV RMS)	-15 dBV (180 mV RMS)	+20dBV (10.0 V RMS)
Line	-25 dBV (55 mV RMS)	+16 dBV (6.3 V RMS)	+20 dBV (10.0 V RMS)
Headphone Output	1/4" TRS stereo jack, mono signal, 15.7 mW, maximum in 33 Ω (level adjustable in menu 0 to -40 dB in 2 dB steps)		
Line Output	RCA jack (black), -10 dBV (.32 VRMS); Output impedance 100 Ω		
Ethernet	RJ-45 on back of unit (PPA T45NET only) supports CAT5e cable lengths up to 328 feet (100 meters); 10/100 Base-T IEEE 802.3 compliant, unique MAC address		
Approvals	FCC, RoHS2, WEEE, Industry Canada		
Warranty	Lifetime PLUS Limited Warranty (90 Days on most accessories)		

NOTE: SPECIFICATIONS SUBJECT TO CHANGE WITHOUT NOTICE

** Stresses above these ratings may cause permanent damage. Exposure for extended periods may degrade reliability.

This device complies with Industry Canada licence-exempt RSS standard(s) and FCC part 15.105[b] for the United States.

Operation is subject to the following two conditions: [1] this device may not cause interference, and [2] this device must accept any interference, including interference that may cause undesired operation of the device.

This device complies with Industry Canada licence-exempt RSS standard(s). Operation is subject to the following two conditions: (1) This device may not cause interference, and (2) this device must accept any interference, including any interference that may cause undesired operation of the device.

Cet appareil est conforme à la norme RSS Industrie Canada exempt de licence. Son fonctionnement est soumis aux deux conditions suivantes: (1) cet appareil ne doit pas provoquer d'interférences et (2) cet appareil doit accepter toute interférence, y compris les interférences pouvant causer un mauvais fonctionnement du dispositif.

This device complies with ICES-003 class B. Test data is available from the manufacturer on request.

Note: This equipment has been tested and found to comply with the limits for a Class B digital device, pursuant to part 15 of the FCC Rules. These limits are designed to provide reasonable protection against harmful interference in a residential installation. This equipment generates, uses and can radiate radio frequency energy and, if not used in accordance with the instructions, may cause harmful interference to radio communications. However, there is no guarantee that interference will not occur in a particular installation. If this equipment does cause harmful interference to radio or television reception, which can be determined by turning the equipment off and on, the user is encouraged to try to correct the interference by one or more of the following measures:

- Reorient or relocate the receiving antenna.
- Increase the separation between the equipment and the receiver.
- Connect the equipment into an outlet on a circuit different from that to which the receiver is connected.
- Consult the dealer or an experienced radio/TV technician for help.

Note: FCC regulations, section 15.21, requires the user to comply with the rules of transmitter operation. Any changes or modifications made by the user not expressly approved for compliance may result in the loss of all privileges and authority to operate the equipment.

System Specifications PPA R38 Receiver

Dimensions	4.1" x 2.85" x 1.38" (104 x 72 x 35mm)
Weight	4.6oz (130g) with batteries. 2.6oz (73g) without batteries
Color	Black/Silver. Black ABS Plastic case with Aluminum faceplate
Battery Type	(2) AA Alkaline or (2) AA NiMH Rechargeable
Battery Life	(2) AA non-rechargeable alkaline batteries (BAT 001-2), approx. 50 hrs (2) AA rechargeable NiMH batteries (BAT 026-2), 1500mAh, approx. 32 hrs
Current Consumption	52mA nominal
Operating Temp. Range	32° – 122°F (0° to 50°C)
Channels	17 Wideband, accessed via menu
Operating Frequencies	72.1, 72.2, 72.3, 72.4, 72.5, 72.6, 72.7, 72.8, 72.9, 74.7, 75.3, 75.4, 75.5, 75.6, 75.7, 75.8, 75.9 MHz
FM Deviation	± 75 kHz
De-Emphasis	75 µS
Display Screen	OLED
Power Indication	Power button, backlit green. Good battery strength - glows solid; Low battery - flashes
Sensitivity	2 µV at 12 dB Sinad with squelch defeated
Input Overload	100 mV
Frequency Response	200 Hz – 15 kHz, ±3dB
Modulation	FM, +/- 75 kHz peak deviation
Signal-to-Noise Ratio	Minimum 65 dB @ 100 µV
Receive Antenna	Integral with earphone/headphone cord
Audio Output	35 mW max at 16 Ω
Headphone Connector	3.5 mm stereo jack, mono output for stereo or mono earphones/headphones
Earphone	Stereo, earbud-type with foam cushion, 3.5 mm plug, 32 Ω
Power Save Mode	Enters sleep mode after approximately 6 mins of no RF signal
Approvals	FCC, Industry Canada, RoHS, WEEE
Warranty	Lifetime PLUS Limited Warranty, 90 Days on most accessories

NOTE: SPECIFICATIONS SUBJECT TO CHANGE WITHOUT NOTICE

This device complies to "RSS-Gen Issue 2 June 2007" for Industrie Canada and FCC part 15.105(b) for the United States. Operation is subject to the following two conditions: (1) this device may not cause interference, and (2) this device must accept any interference, including interference that may cause undesired operation of the device. This device complies with ICES-003 class B. Test data is available from the manufacturer on request.

System Specifications PPA R35-8 Receiver

Dimensions	4.1" x 2.85" x 1.38" (104 x 72 x 35mm)
Weight	4.6oz (130g) with batteries. 2.6oz (73g) without batteries
Color	Black
Battery Type	Two (2) AA non-rechargeable alkaline batteries (BAT 001), approx. 50 hours battery life or Two (2) AA rechargeable NiMH batteries (BAT 026), 1500 mAh, approx 32 hours battery life
Current Consumption	Nominal 40 mA
Operating Freq	72-76 MHz, 8 channels: 72.1, 72.3, 72.6, 72.8, 74.7, 75.4, 75.7, or 75.9 MHz
Intermediate Freq	10.7 MHz
FM Deviation	+/- 75 kHz
De-emphasis	75 µS
LED Indicator	Power: Red. Low Battery: Flashes
Sensitivity	2 µV at 12 dB SINAD with squelch defeated
Input Overload	20 mV
Frequency Response	40 Hz to 15 kHz +/- 3 dB
Signal to Noise ratio	60 dB at 100 µV
Receive Antenna	Integral with earphone/headphone cord
Audio Output	35 mW, max 16 ohm load
Output Connector	3.5 mm mono phone jack
Squelch	Located inside battery door. Factory set for 25 dB S/N. Squelch may be set with JFD-7104-5 from Sprague Goodman or any flat tipped tuning tool with tip size 0.095" X 0.016"
Notes	The R35-8 is NOT field tunable; the eight channels have been carefully selected to inhibit inter-modulation interference
Approvals	FCC, Industry Canada, RoHS, WEEE
Warranty	Lifetime PLUS Limited Warranty. 90 days on cords, earphones, headphones, batteries, and other accessories

NOTE: SPECIFICATIONS SUBJECT TO CHANGE WITHOUT NOTICE

This device complies to "RSS-Gen Issue 2 June 2007" for Industrie Canada and FCC part 15.105(b) for the United States. Operation is subject to the following two conditions: (1) this device may not cause interference, and (2) this device must accept any interference, including interference that may cause undesired operation of the device. This device complies with ICES-003 class B. Test data is available from the manufacturer on request.

System Specifications PPA R37 Receiver

Dimensions	4.1" x 2.85" x 1.38" (104 x 72 x 35mm)
Weight	4.6 oz (130 g) with batteries. 2.6 oz (73 g) without batteries
Color	Black
Battery Type	2 AA Alkaline or 2 AA NiMH
Battery Life	Two AA non-rechargeable alkaline batteries (BAT 001), approx. 50 hrs Two AA rechargeable NiMH batteries (BAT 026), 1500 mAh, approx. 32 hrs
Current Consumption	52 mA nominal
Temperature Range	32° to 122° F (0° to 50° C)
Channels	17, accessed via seek button in battery compartment
Operating Freq.	72.1, 72.2, 72.3, 72.4, 72.5, 72.6, 72.7, 72.8, 72.9, 74.7, 75.3, 75.4, 75.5, 75.6, 75.7, 75.8, 75.9 MHz
Intermediate Freq.	75 kHz
FM Deviation	± 75 kHz
De-Emphasis	75 µS
LED Indicator	Power: Green; Low Battery: Flashes Green
AFC Range	± 120 kHz
Sensitivity	2 µV at 12 dB Sinad with squelch defeated
Input Overload	100 mV
Frequency Response	200 – 15 kHz
Modulation	FM, +/- 75 kHz peak deviation
Signal-to-Noise Ratio	65 dB min @ 100 µV
Receive Antenna	Integral with earphone/headphone cord
Audio Output	35 mW max, peak into 16 ohms
Output Connector	3.5 mm stereo/mono phone jack
Earphone	Earbud-type with foam cushion, 3.5 mm plug, 32 Ω
Auto Shut-off	Enters sleep mode after approx 6 mins of no RF signal
Approvals	FCC, Industry Canada, RoHS, WEEE
Warranty	Lifetime PLUS Limited Warranty. 90 days on cords, earphones, headphones, batteries and other accessories

NOTE: SPECIFICATIONS SUBJECT TO CHANGE WITHOUT NOTICE

This device complies to "RSS-Gen Issue 2 June 2007" for Industrie Canada and FCC part 15.105(b) for the United States. Operation is subject to the following two conditions: (1) this device may not cause interference, and (2) this device must accept any interference, including interference that may cause undesired operation of the device. This device complies with ICES-003 class B. Test data is available from the manufacturer on request.

Lifetime PLUS Limited Warranty

Williams Sound products are engineered, designed, and manufactured under carefully controlled conditions to provide you with many years of reliable service.

Williams Sound warrants the Personal PA® FM Listening transmitters and receivers (models PPA T45, PPA T45NET, PPA T27, PPA T46, PPA R38, PPA R37, and PPA R35-8) against defects in materials and workmanship under normal use and conditions for the useful lifetime of the product from date of purchase.

This warranty is available to the original end purchaser of the product and CAN BE transferred to subsequent purchasers of the product.

Microphones, earphones, headphones, batteries, chargers, cables, carry cases, and most other accessory products carry a 90-day warranty.

Williams Sound has no control over the conditions under which this product is used. Williams Sound, therefore, disclaims all warranties not set forth above, both express and implied, with respect to the Personal PA® FM Listening System, including but not limited to, any implied warranty of merchantability or fitness of use of such equipment including, without limitation, any warranty that the use of such equipment for any purpose will comply with applicable laws and regulations. Williams Sound shall not be liable to any person or entity for any medical expenses or any direct, incidental or consequential damages caused by any use, defect, failure or malfunctioning of the product, whether a claim for such damages is based upon warranty, contract, tort or otherwise, the sole remedy for any defect, failure or malfunction of the products is replacement of the product. No person has any authority to bind Williams Sound to any representation or warranty with respect to the Personal PA® FM Listening System. Unauthorized repairs or modifications will void the warranty. This warranty is void if damage occurred because of misuse, or if the product has been repaired or modified by anyone other than a factory authorized service technician. Warranty does not cover normal wear and tear on the product or any other physical damage unless the damage was the result of a manufacturing defect. Williams Sound is not liable for consequential damages due to any failure of equipment to perform as intended. Williams Sound shall bear no responsibility or obligation with respect to the manner of use of any equipment sold by it.

This warranty does not cover reimbursement for your costs of removing and transporting the product for warranty service evaluation or installation of any replacement product provided under this warranty.

The exclusions and limitations set out above are not intended to, and should not be construed so as to contravene mandatory provisions of applicable law. If any part or term of this Disclaimer of Warranty is held to be illegal, unenforceable, or in conflict with applicable law by a court of competent jurisdiction, the validity of the remaining portions of this Disclaimer of Warranty shall not be affected, and all rights and obligations shall be construed and enforced as if this Limited Warranty did not contain the particular part or term held to be invalid. The terms of the warranty are governed by the laws of the State of Minnesota.

Prices and the specifications of the products are subject to change without notice.

*For Complete Warranty Statement go to: www.williamssound.com/warranty-statement

NOTICE: Williams Sound products are NOT designed for use in extreme temperature, humidity or chemical environments. The introduction of chemicals such as chlorine, salt water or human sweat into the product will cause damage to the circuitry. Damage due to these causes is NOT covered under the Product Warranty.

If you experience difficulty with your system, call Toll-Free for Customer Assistance 1-800-843-3544 (U.S.A.) or +1 952 943 2252 (Outside the U.S.A.)

If it is necessary to return the system for service, your Customer Service Representative will give you a Return Authorization Number (RA) and shipping instructions.

This page intentionally left blank



10300 Valley View Rd • Eden Prairie, MN 55344
800-328-6190 / 952-943-2252 • FAX: 952-943-2174
www.williamssound.com