



AP-S15A AC Power Conditioner & Distribution Unit



1601 Jack McKay Blvd. • Ennis, Texas 75119 U.S.A.
Telephone: 800.876.3333 • Fax: 800.765.3435



Table of Contents

Important Safety Instructions..... 3
Introduction 5
Key Features and Applications 6
Front Panel Description..... 7
Rear Panel Description..... 8
Installation 9
AC Power Cord Retainer System 9
Specifications 11
Warranty..... 12





Important Safety Instructions



The lightning flash with arrowhead symbol within an equilateral triangle, is intended to alert the user to the presence of uninsulated "dangerous voltage" within the product's enclosure that may be of sufficient magnitude to constitute a risk of electric shock to persons.



The exclamation point within an equilateral triangle is intended to alert the user to the presence of important operating and maintenance (servicing) instructions in the literature accompanying the product.



1. Read these instructions.
2. Keep these instructions.
3. Heed all warnings.
4. Follow all instructions.
5. Do not use this device near water.
6. Clean only with dry cloth.
7. Do not block any ventilation openings. Install in accordance with the manufacturer's instructions.
8. Do not install near any heat sources such as radiators, heat registers, stoves, or other device (including amplifiers) that produce heat.
9. Do not defeat the safety purpose of the polarized or grounding-type plug. A polarized plug has two blades with one wider than the other. A grounding type plug has two blades and a third grounding prong. The wide blade or the third prong are provided for your safety. If the provided plug does not fit into your outlet, consult an electrician for replacement of the obsolete outlet.
10. Protect the power cord from being walked on or pinched particularly at plugs, convenience receptacles, and the point where they exit from the device.
11. Only use attachments/accessories specified by the manufacturer.
12. Use only with the cart, stand, tripod, bracket, or table specified by the manufacturer, or sold with the device. When a cart is used, use caution when moving the cart/device combination to avoid injury from tip-over.
13. Unplug this device during lightning storms or when unused for long periods of time.
14. Refer all servicing to qualified service personnel. Servicing is required when the device has been damaged in any way, such as liquid has been spilled, or objects have fallen into the device, the device has been exposed to rain or moisture, does not operate normally, or has been dropped.
15. **WARNING:** To reduce the risk of fire or electric shock, this device should not be exposed to rain or moisture and objects filled with liquids, such as a vase, should not be placed on this device.
16. To completely disconnect this equipment from the mains, disconnect the power supply cord plug from the receptacle.
17. The mains plug of the power supply cord shall remain readily operable.



1601 Jack McKay Blvd. • Ennis, Texas 75119 U.S.A.
Telephone: 800.876.3333 • Fax: 800.765.3435



WARNING When The Device Is In Use

- To prevent electric shock, do not remove the product cover as there are high voltage components inside. Refer all servicing to Atlas Sound.
- Should any of the following irregularities occur during use, immediately switch off the power, disconnect the power cord from the AC outlet and contact Atlas Sound. Do not attempt to continue operation with the product as this may cause fire or electric shock:
 - Smoke or strange smell coming from the unit.
 - If the product falls or the case is damaged.
 - If water or any metallic objects falls into the product.
 - If the power supply cord is damaged in any way.
 - If the unit is malfunctioning.
- Do not insert or drop metallic objects or flammable materials into the ventilation holes of the product's cover, as this may result in electric shock or fire.
- Do not place any containers with liquid or metallic objects on the top of the product. If any liquid spills into the unit, fire or electric shock may result.
- Never operate this product or touch the power supply cord during an electrical storm, electric shock may result.
- Never exceed the power rating on the product when connecting equipment. Fire and/or property damage may result.
- Operate the product only with the voltage specified on the unit. Fire and/or electric shock may result if a higher voltage is used.
- Do not modify, kink, or cut the power cord. Do not place the power cord in close proximity to heaters and do not place heavy objects on the power cord, including the product itself, doing so may result in fire or electrical shock.
- Ensure that the safety ground terminal is connected to a proper ground. Never connect the ground to a gas pipe as a catastrophic disaster may result.
- Be sure the installation of the product is stable, avoid slanted surfaces as the product may fall and cause injury or property damage.



CAUTION When Installing The Product

- Plugging in or unplugging the power cord with wet hands may result in electric shock.
- Never move the unit with the power cord plugged into the wall, as damage to the power cord may result.
- When unplugging the cord from the wall, grasp the plug, NOT the cord.
- Never install this product in humid or dusty locations, nor in direct sunlight, near sources of heat, or in areas where sooty smoke or steam are present. Fire and electric shock may result.
- Keep all sides of the unit at least 3½" away from objects that may obstruct air flow to prevent the unit's internal temperature rise.



CAUTION When The Product Is In Use

- Never place heavy objects on the product, causing it to fall and/or break, resulting in personal injury and property damage. In addition, the product itself may fall and cause injury and property damage.
- Contact Atlas Sound for instructions on cleaning the inside of the unit. Large accumulations of dust inside the unit may result in heat buildup and fire.
- Ensure that the power supply plug is securely plugged into the wall outlet. Never allow dust to accumulate on the power plug or inside the wall outlet.
- When cleaning the unit or the unit is not to be operated for an extended period, unplug the power cord from the wall.





Introduction

Thank you for purchasing the Atlas Power AP-S15A AC Power Conditioner & Distribution Unit. The AP-S15A has been designed to meet most installation requirements for AC power distribution and equipment power protection.

The AP-S15A features noise filtering for unwanted Radio Frequency Interference (RFI) that is commonly introduced into AC lines by nearby radio transmitters or wireless products. EMI filters are incorporated to reduce noise from Electromagnetic Interference (EMI) from such items as electric motors and switching power supplies. The benefit of these filters can be seen on video products or audibly by reducing static pops and external signal interference.

The AP-S15A is unique in that the integrator can select the power cord length that is required for the installation. A removable 12' IEC power cord with a retainer bracket is supplied with the unit. A shorter or longer cord can be purchased separately if needed.

Unstable AC Mains voltage is one of the main reasons for equipment failure. The amount of energy that can be injected into the power system can be immense with voltages reaching 6kV or amperage peaks of 3000A. These spikes are very fast and usually only last for a very short period of time. The AP-S15A's circuitry is very fast and can suppress unwanted energy within a nanosecond response and sustain the suppression up to 2 milliseconds, thus ensuring virtually trouble free protection. The front panel also features AC fault and ground status indicators providing quick, visual reassurance the equipment is safe.

The AP-S15A offers power management control, noise filtering, and spike/surge protection, making it the most compact, effective power management protection system on the market today.



1601 Jack McKay Blvd. • Ennis, Texas 75119 U.S.A.
Telephone: 800.876.3333 • Fax: 800.765.3435



Key Features

- 9 Total Outlets
 - 7 Rear Panel Switched Outlets
 - 1 Rear Panel Unswitched Outlet
 - 1 Front Panel Unswitched Convenience Outlet
- RFI Noise Filtering to Reduce Radio Frequency Interference
- EMI Filtering to Reduce Electromagnetic Interference
- Circuit Breaker Protection @ 15A
- Spike Suppression up to 6000V
- AC Fault Indicator
- Ground Status Indicator
- Removable IEC Power Cord with a Retainer Bracket

Applications

The AP-S15A was designed to be flexible with features that allow it to be used in a variety of applications. The AP-S15A can be used solely for protection against voltage surges or for AC distribution. If fuzzy video or frequent static pops occur, the AC power conditioning may eliminate or reduce those inconveniences. The following are just a few examples of applications where the AP-S15A can be used:

- Restaurants
- Houses of Worship
- Schools
- Home Theaters
- Office Buildings
- Sports Bars



1601 Jack McKay Blvd. • Ennis, Texas 75119 U.S.A.
Telephone: 800.876.3333 • Fax: 800.765.3435



Front Panel Features

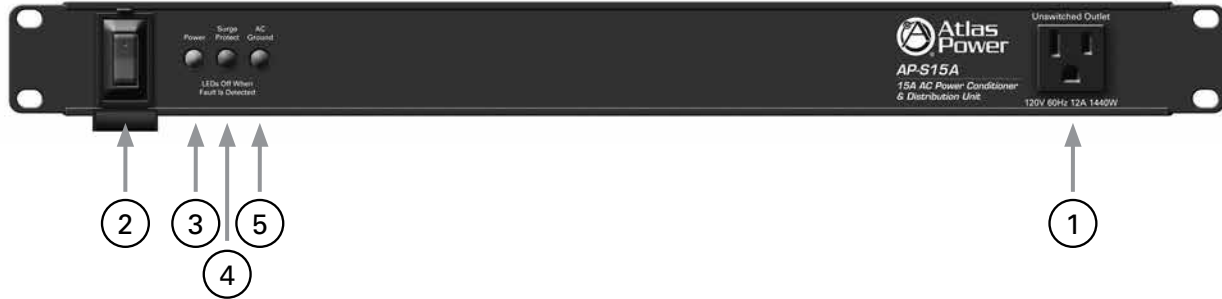

1. Unswitched AC Outlet

The 120VAC outlet is always live when the AP-S15A power cord is plugged into an AC mains power source. **Note:** The AC mains power switch does not affect the Unswitched AC Outlet but it is protected with surge protection circuitry.

2. Power Switch & Cover

To turn the AP-S15A On or Off, press the switch to the On or Off position. When in the On position and AC voltage is present the power LED will illuminate. The AP-S15A incorporates a power switch cover to prevent accidental pressing of the power switch.

3. Switched Outlets Active Indicator

This LED will illuminate Blue when the power switch is in the On position.

4. Surge Protect Indicator

The Surge Protect LED is illuminated under normal operating conditions showing that the surge protection circuit is functioning correctly and the connected equipment is protected from voltage transients. Although the clamping suppression circuit virtually assures protection from most transient voltage spikes and surges, nature has a way of occasionally creating electrical forces that are beyond the capabilities of any device to absorb without some degree of damage. In the rare instance that this occurs and the circuit has been damaged, the Red "Surge Protect" LED indicator will turn off. The AP-S15A will shut off permanently until the unit is repaired. Be advised that activation of this fault condition and the associated repair is not covered under warranty. **Note:** If the Surge Protect LED is not illuminated while the unit is powered on, it is important to have all equipment that was connected to that AC Mains Line inspected for proper operation.

5. Ground Status Indicator

This LED will illuminate Green when the AP-S15A has Earth ground connection on the Earth ground pin of the AC Mains power cord.

Note: If there is no Earth ground connection the LED will not illuminate and the AC wall outlet must be repaired by a qualified electrician before continuing.



1601 Jack McKay Blvd. • Ennis, Texas 75119 U.S.A.
Telephone: 800.876.3333 • Fax: 800.765.3435



Rear Panel Features



1. AC Mains Input

Connect the IEC 14 Gauge 12' (4m) power cord to a 15A 120VAC outlet to provide power to the AP-S15A.

2. AC Mains Input IEC Power Cord Retainer

The AP-S15A incorporates an IEC power cord retainer bracket to prevent the cord from coming loose. See IEC power cord retainer bracket installation.

3. AC Mains Power Breaker

The 15A rated breaker will open if the combined draw of all AC outlets exceeds 15A. **Note:** The breaker is designed to exceed its rating for a short period of time. If the breaker is tripped, the load must first be removed from the AP-S15A before pushing to reset.

4. Unswitched AC Outlet

The 120VAC outlet is always live when the AP-S15A power cord is plugged into an AC mains power source. **Note:** The AC mains power switch does not affect the Unswitched AC Outlet but it is protected with surge protection circuitry.

5. Switched AC Outlets

The seven 120VAC outlets are always live when the AP-S15A front panel power switch is in the On position.





Installation

Before installing, read the entire manual to ensure proper understanding of operation and that all features are being utilized. The AP-S15A can be placed on a shelf or rack mounted in a standard 19" width rack. When rack mounted, placement within the rack is flexible, however the AP-S15A should be within 6' of a dedicated 15A AC outlet. When rack mounting, use rack rail type screws of $1\frac{1}{2}$ " x 1". Always make sure the 15A outlet is properly inspected by a certified electrician prior to connecting the AP-S15A. Make sure to inspect the equipment that will be connected to the AP-S15A to ensure it does not exceed 15A total amperage draw.

AC Power Cord Retainer System

Connect the IEC 14 Gauge 12' (4m) power cord to a 15A 120VAC outlet to provide power to the AP-S15A by aligning the pins of the cord to the pins on the chassis and inserting the cord. Press firmly to assure a good connection.

The AP-S15A incorporates an IEC Power Cord retainer bracket to prevent the cord from coming loose. To install the IEC power cord retainer bracket, remove the two screws from the chassis of the AP-S15A, place the retainer bracket over the cord and insert the two screws through the bracket into the chassis as illustrated below.

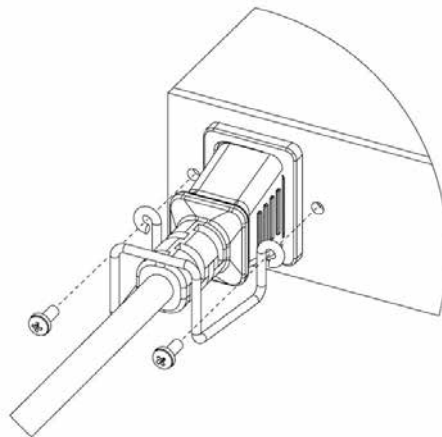



Specifications

Type	Power Conditioner & Suppressor
Load Rating	15A
Safety Listings	ETL (UL 60065 Standard)

Front Panel

Outlets	1 Unswitched
Activation Switch	Rocker with Security Cover
Indicators	AC Power On, Outlets Active, AC Fault, Ground

Rear Panel

AC Outlets	8 Outlets Total, 7 Switched & 1 Unswitched
AC Mains IEC Power Socket	15A 1800W
Circuit Breaker	15A Resettable

Technical Data

Max AC Mains Current	15A AC Mains Breaker
Operating Voltage	102VAC - 132VAC
Power Consumption	6 Watts
Min. Spike Clamping Voltage	460 VRMS @ 3,000A
Max. Spike Clamping Voltage	6kV
Max. Spike Clamping Resp. Time	1 nanosecond
Spike Clamping Voltage @ 100A	1250Vp for 20 μ s
Maximum Surge Current	6,500A
Energy Rating @ 2ms	200 Joules
Noise Attenuation RFI	10dB @ 10kHz / 40dB @ 100kHz / 100dB @ 10MHz
Temperature Range	5° to 35°C
Humidity Range	5% to 95% Relative Humidity

Mechanical

Chassis Finish	Black
Mounting	Rack Mount, 19", 1 RU
Height	1.75" (1RU, 44.5mm)
Width	19" (482.6mm)
Depth	5" (127mm)
Weight	5 lbs (2.27kg)

In the Box

Manual
IEC Power Cord 14 Gauge 12ft (4M)
IEC Power Cord Retainer Bracket



1601 Jack McKay Blvd. • Ennis, Texas 75119 U.S.A.
Telephone: 800.876.3333 • Fax: 800.765.3435



Limited Warranty

All products manufactured by Atlas Sound are warranted to the original dealer/installer, industrial or commercial purchaser to be free from defects in material and workmanship and to be in compliance with our published specifications, if any. This warranty shall extend from the date of purchase for a period of three years on all Atlas Sound products, including SOUNDOLIER brand, and ATLAS SOUND brand products except as follows: one year on electronics and control systems; one year on replacement parts; and one year on Musician Series stands and related accessories. Additionally, fuses and lamps carry no warranty. Atlas Sound will solely at its discretion, replace at no charge or repair free of charge defective parts or products when the product has been applied and used in accordance with our published operation and installation instructions. We will not be responsible for defects caused by improper storage, misuse (including failure to provide reasonable and necessary maintenance), accident, abnormal atmospheres, water immersion, lightning discharge, or malfunctions when products have been modified or operated in excess of rated power, altered, serviced or installed in other than a workman like manner. The original sales invoice should be retained as evidence of purchase under the terms of this warranty. All warranty returns must comply with our returns policy set forth below. When products returned to Atlas Sound do not qualify for repair or replacement under our warranty, repairs may be performed at prevailing costs for material and labor unless there is included with the returned product(s) a written request for an estimate of repair costs before any nonwarranty work is performed. In the event of replacement or upon completion of repairs, return shipment will be made with the transportation charges collect.

EXCEPT TO THE EXTENT THAT APPLICABLE LAW PREVENTS THE LIMITATION OF CONSEQUENTIAL DAMAGES FOR PERSONAL INJURY, ATLAS SOUND SHALL NOT BE LIABLE IN TORT OR CONTRACT FOR ANY DIRECT, CONSEQUENTIAL OR INCIDENTAL LOSS OR DAMAGE ARISING OUT OF THE INSTALLATION, USE OR INABILITY TO USE THE PRODUCTS. THE ABOVE WARRANTY IS IN LIEU OF ALL OTHER WARRANTIES INCLUDING BUT NOT LIMITED TO WARRANTIES OF MERCHANTABILITY AND FITNESS FOR A PARTICULAR PURPOSE.

Atlas Sound does not assume, or does it authorize any other person to assume or extend on its behalf, any other warranty, obligation, or liability. This warranty gives you specific legal rights and you may have other rights which vary from state to state.

Service

Should your AP-S15A require service, please contact the Atlas Sound warranty department at 1-877-689-8055, ext. 277 to obtain an RA number.

Atlas Sound Tech Support can be reached at 1-800-876-3333.

Visit our website at www.AtlasSound.com to see other Atlas products.

©2014 Atlas Sound L.P. All rights reserved. Atlas Sound is a trademark of Atlas Sound L.P.
All other trademarks are the property of their respective owners. ATS004891 RevA 8/14



1601 Jack McKay Blvd. • Ennis, Texas 75119 U.S.A.
Telephone: 800.876.3333 • Fax: 800.765.3435